

EasyADC™

Manual

All Mikroelektronika's development systems feature a large number of peripheral modules expanding microcontroller's range of application and making the process of program testing easier. In addition to these modules, it is also possible to use numerous additional modules linked to the development system through the I/O port connectors. Some of these additional modules can operate as stand-alone devices without being connected to the microcontroller.

Additional Board

 **MikroElektronika**

SOFTWARE AND HARDWARE SOLUTIONS FOR EMBEDDED WORLD ...making it simple

EasyADC

The EasyADC additional board is used to convert an analog voltage signal into the appropriate 12-bit digital number. The analog voltage signal is supplied via four separate channels. Communication between the additional board and a microcontroller is performed via the Serial Peripheral Interface (SPI).

Key features:

- 12-bit resolution;
- SPI serial interface (modes 0,0 and 1,1);
- 100 ksps max. sampling rate at VDD = 5V;
- 50 ksps max. sampling rate at VDD = 2.7V;
- Single supply operation: 2.7V - 5.5V; etc.

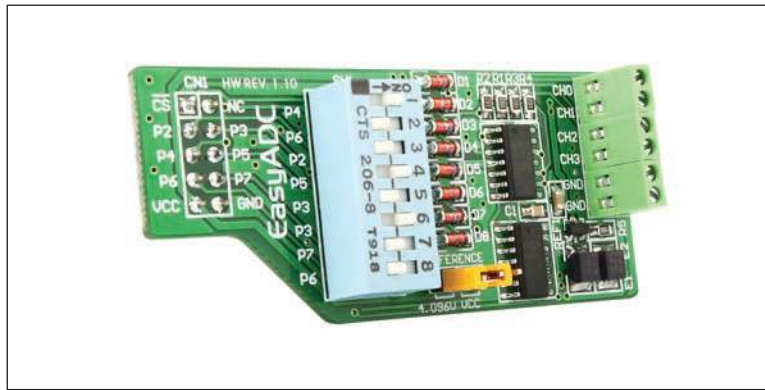

Figure 1: EasyADC additional board

How to connect the board?

The EasyADC additional board is connected to a development system via a 2x5 connector on the additional board and a 2x5 connector on the development system. Two screw terminals CN2 and CN3 are used to supply a signal for conversion through, whereas the CN4 connector is used for ground. The DIP switch SW1 is used to select the development system to connect the EasyADC board to. Jumper J1 is used for reference voltage (VREF) selection. When jumper J1 is in 4.096V position pin VREF is supplied with 4.096V, jumper J1 in VCC position supplies VREF with VCC voltage.

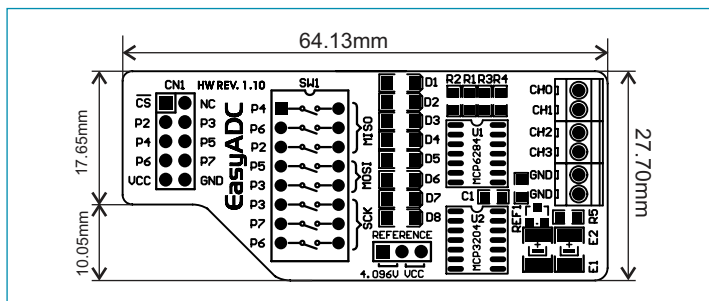

Figure 2: Dimensions of the EasyADC additional board

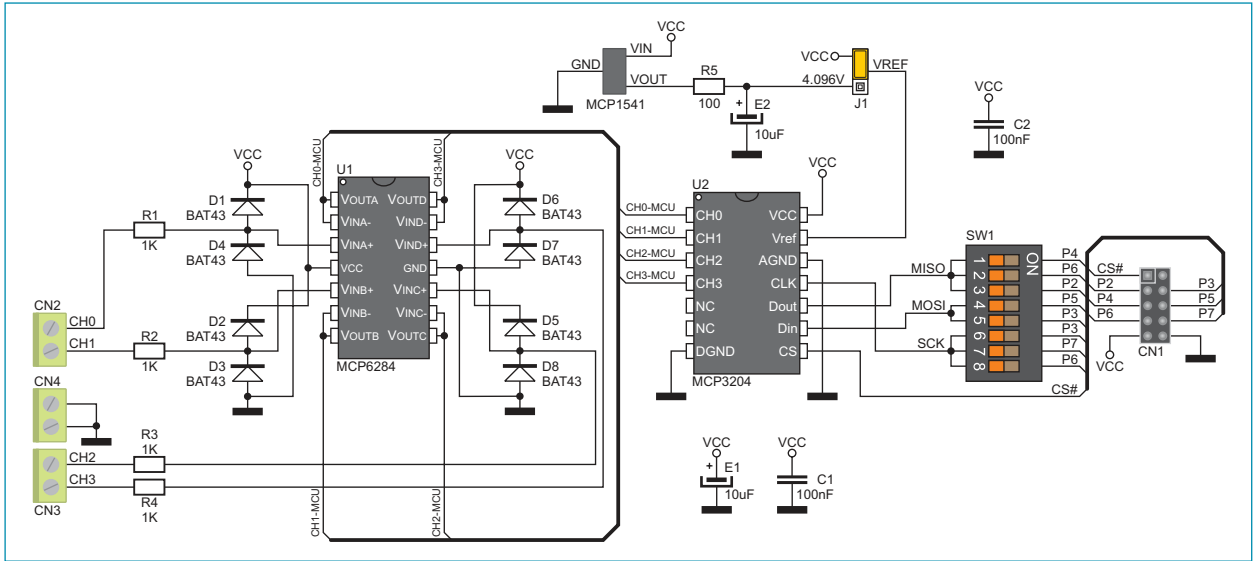

Figure 3: EasyADC additional board connection schematic

	MISO	MOSI	SCK
PIC	1 (P4)	4 (P5)	6 (P3)
dsPIC	3 (P2)	5 (P3)	8 (P6)
AVR-8051	2 (P6)	4 (P5)	7 (P7)
Position of DIP switch SW1 for appropriate development system			

Table 1

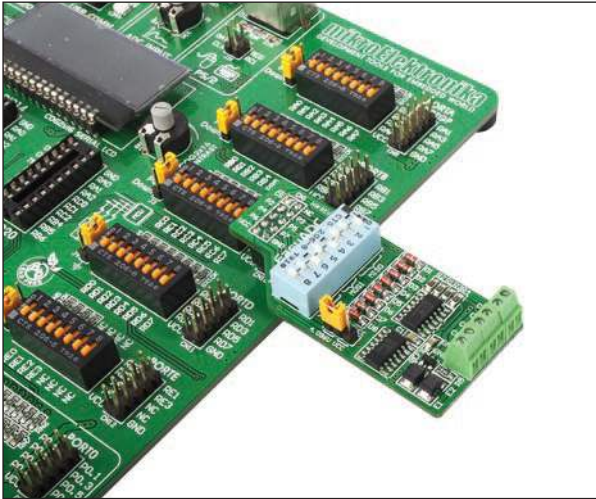

Figure 4: EasyADC connected to a development system



MikroElektronika

SOFTWARE AND HARDWARE SOLUTIONS FOR EMBEDDED WORLD ...making it simple

If you want to learn more about our products, please visit our website at www.mikroe.com

If you are experiencing some problems with any of our products or just need additional information, please place your ticket at www.mikroe.com/en/support

If you have any questions, comments or business proposals, do not hesitate to contact us at office@mikroe.com