

LOC	DIST	REVISIONS			
DF	AO	REV	DESCRIPTION	DATE	BY
B		1	REV PER ECO 07-005654	3-12-07	CT

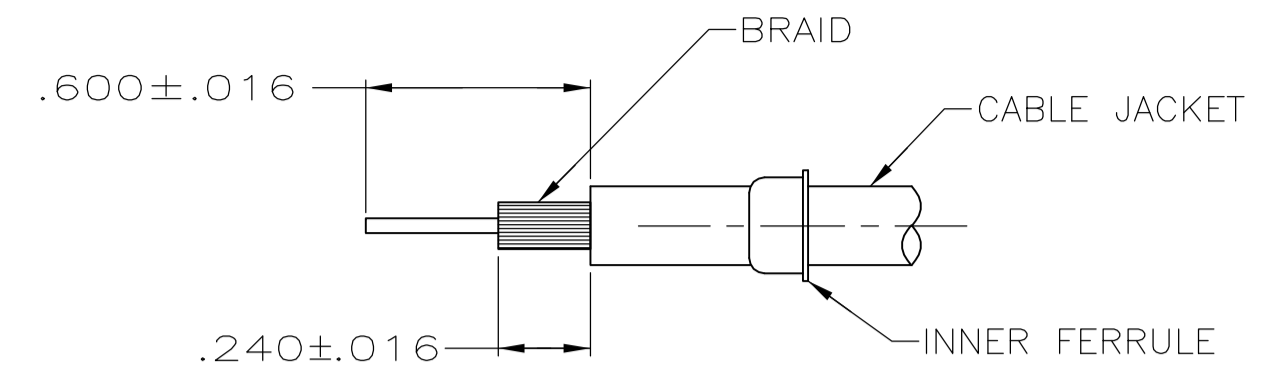

1. CABLE PREPARATION:
- SLIDE INNER FERRULE ONTO CABLE MAKING SURE TO KEEP THE LARGER DIAMETER OF INNER FERRULE OPPOSITE FROM THE END OF THE CABLE BEING TERMINATED. (SEE FIGURE #1)
  - STRIP OUTER JACKET AND BRAID AS INDICATED IN FIGURE #1. CARE SHOULD BE TAKEN NOT TO NICK OR CUT THE BRAID STRANDS DURING THE REMOVAL OF THE JACKET.
  - SLIDE FERRULE FORWARD UNTILL KNURLED END IS EVEN WITH TRIMMED EDGE OF OUTER CABLE JACKET. COMB OUT SHIELD, FOLD SHIELD BACK OVER THE KNURLED PORTION OF THE FERRULE. TRIM THE SHIELD EVEN WITH THE BOTTOM OF THE FERRULE CAP.
  - TRIM CENTER CONDUCTOR AND DIELECTRIC AS SHOWN IN FIGURE 2.

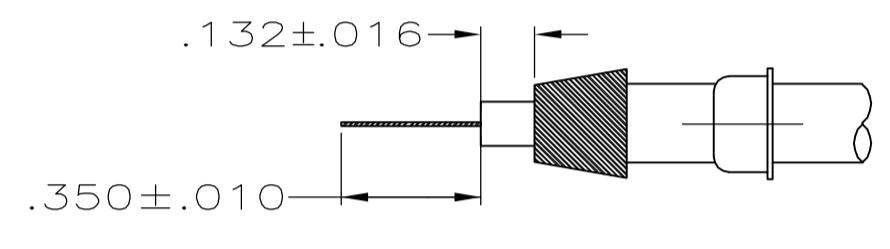
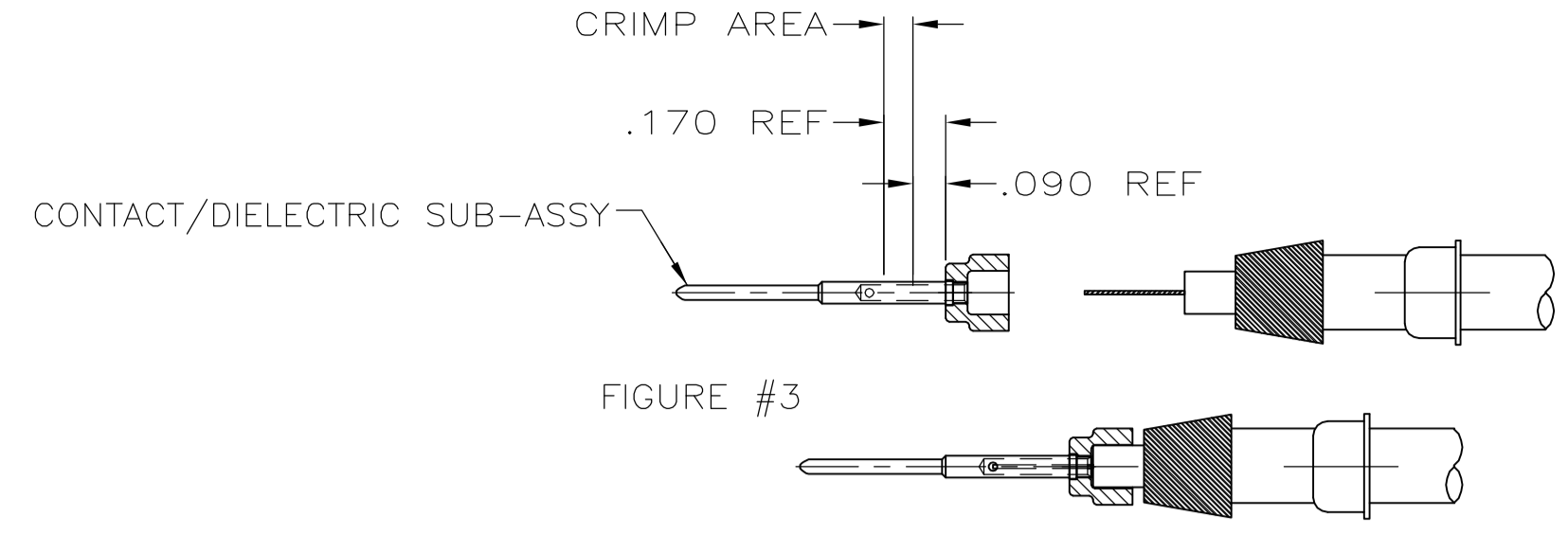
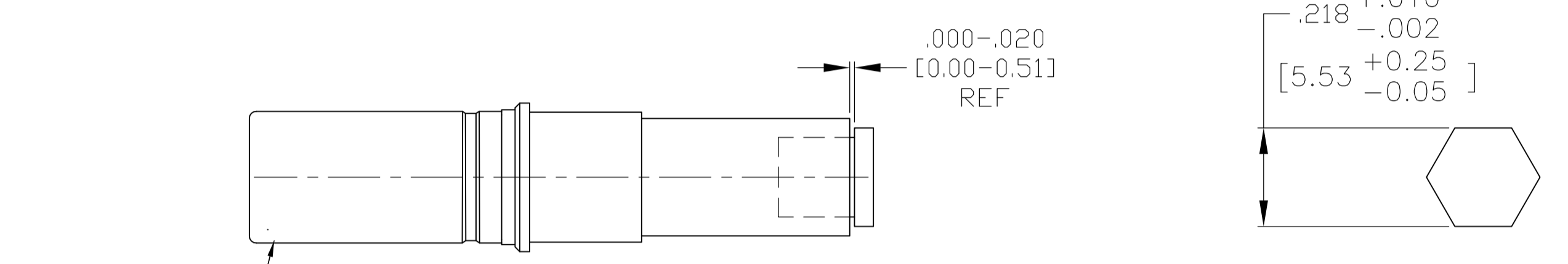

FIGURE #2  
SCALE 2:1



2. CRIMPING:
- CENTER CONDUCTOR- CRIMP CENTER CONDUCTOR USING DANIELS MFG CORP 4-8 INDENT HANDTOOL M22520/2-01. THE HANDTOOL CRIMP SELECTOR SHOULD BE SET TO #5. NO LOCATOR IS NECESSARY. INSERT THE CONTACT/DIELECTRIC SUB-ASSEMBLY INTO HANDTOOL. THE DIELECTRIC WILL POSITION THE CENTER CONTACT. INSERT THE CENTER CONDUCTOR INTO CONTACT WIRE BARREL. THE TIP OF THE STRIPPED WIRE SHOULD BE VISIBLE IN THE WIRE BARREL SIGHT HOLE. CRIMP AND REMOVE CENTER CONTACT. SEE FIGURE #3.
  - INSERT THE CRIMPED CENTER CONTACT AND CABLE INTO OUTER CONTACT BODY. SLIDE FERRULE INTO OUTER CONTACT BODY CAPTURING TRIMMED BRAID BETWEEN FERRULE AND SHELL BODY.
  - FERRULE CRIMP- CRIMP USING HAND TOOL M22520/5-01 AND DIE SET M22520/5-45 OR EQUIVALENT. THIS WILL PRODUCE A HEX CRIMP WITH A NOMINAL DIMENSION OF  $.218$  [5.53] ACROSS THE HEX FLATS. SEE FIGURE #4.



SCALE: NTS  
HEX CRIMP

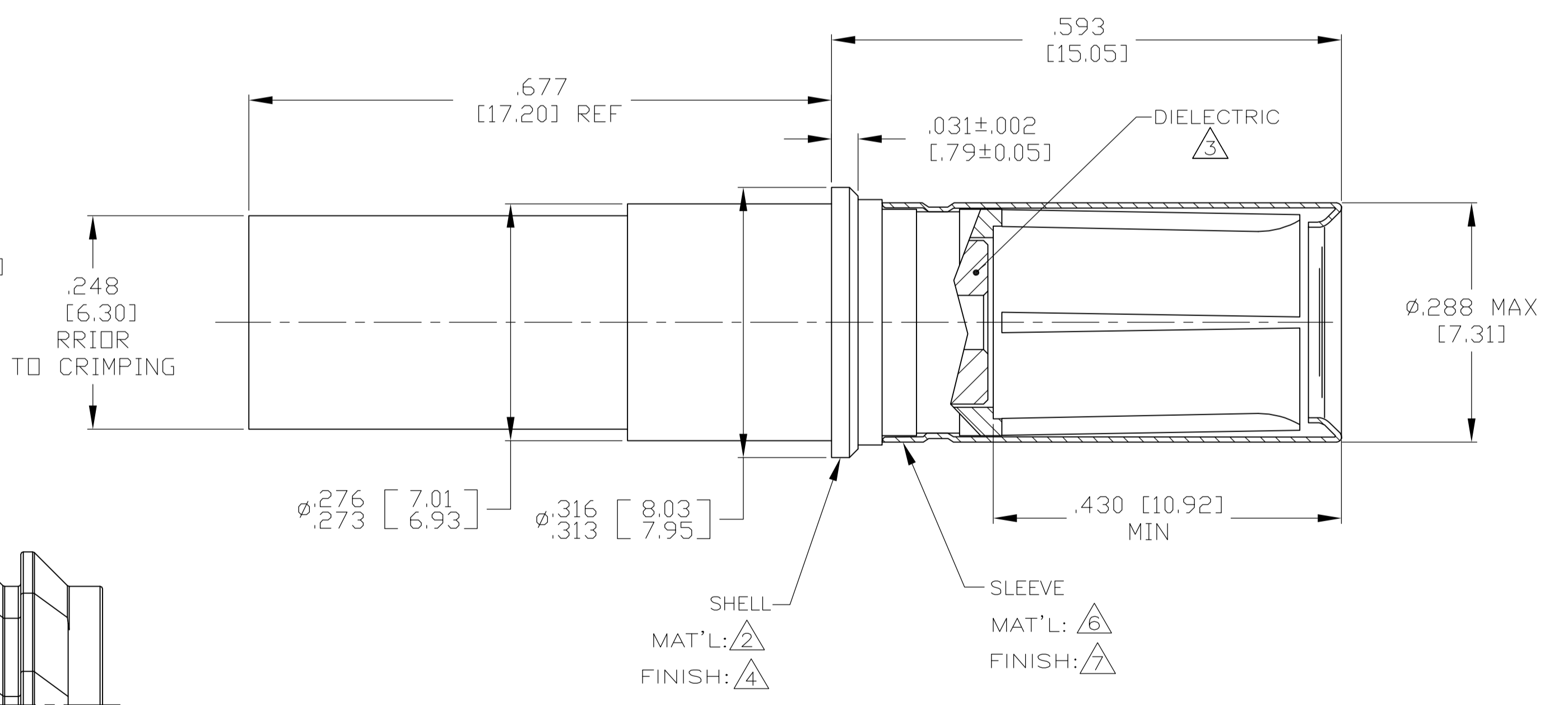
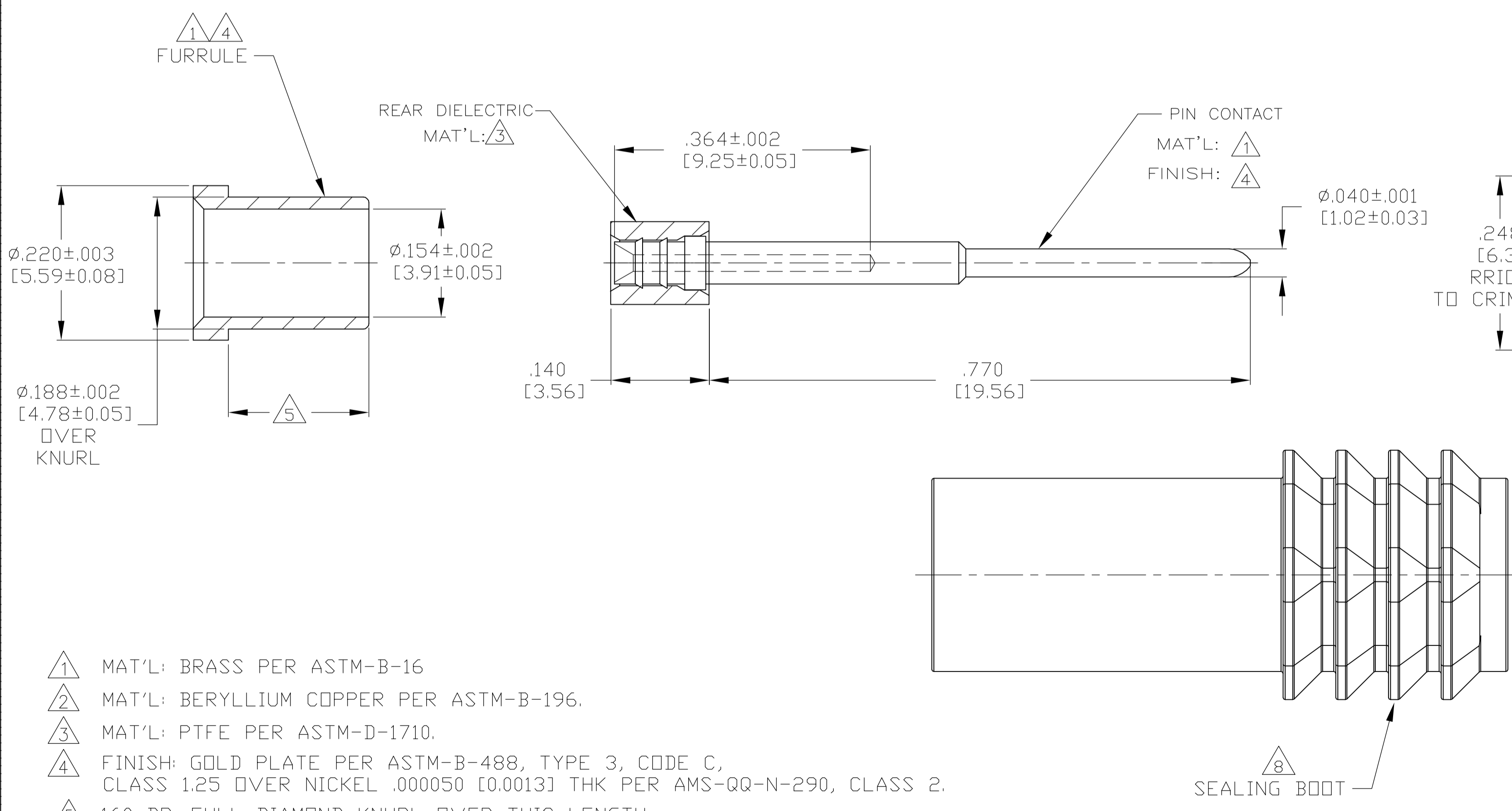

- 1 MAT'L: BRASS PER ASTM-B-16
- 2 MAT'L: BERYLLIUM COPPER PER ASTM-B-196.
- 3 MAT'L: PTFE PER ASTM-D-1710.
- 4 FINISH: GOLD PLATE PER ASTM-B-488, TYPE 3, CODE C, CLASS 1.25 OVER NICKEL .000050 [0.0013] THK PER AMS-QQ-N-290, CLASS 2.
- 5 160 DP. FULL DIAMOND KNURL OVER THIS LENGTH.
- 6 MAT'L: STAINLESS STEEL PER ASTM-A-240.
- 7 FINISH: PASSIVATE PER AMS-QQ-P-35.
- 8 SEALING BOOT IS INCLUDED WITH -2 KIT ONLY.

DESIGNED TO USE BMS 13-65-0F CABLE	
JACKET O.D.:	.141 [3.58]
DIA. OVER DIELECTRIC:	.123 [3.12]
INNER CONDUCTOR O.D.:	.034 [0.86]

WITH SEALING BOOT 8	BMS 13-65-0F	1883369-2
-	BMS 13-65-0F	1883369-1
REMARKS	CABLE	PART NUMBER

THIS DRAWING IS A CONTROLLED DOCUMENT.		DIN C.C.THOMAS 4-4-06	Tyco Electronics Corporation Harrisburg, PA 17105-3608	
DIMENSIONS: INCHES [mm]		CHK R.GROSS 4-4-06	NAME	
TOLERANCES UNLESS OTHERWISE SPECIFIED:		APPRO R.GROSS 4-4-06	PRODUCT SPEC	
0 PLC ± -	1 PLC ± -	APPLICATION SPEC		
2 PLC ± -	3 PLC ± .005 [0.13]	SIZE		
4 PLC ± -	ANGLES ± -	WEIGHT	SCALE 8:1	SHEET 1 OF 1
MATERIAL SEE CALLOUTS	FINISH SEE CALLOUTS	CUSTOMER DRAWING	REV B	