

bq2570x Evaluation Module

The bq25700AEVM-732 and bq25703AEVM-732 evaluation modules (EVM) are SMBus or I²C-controlled NVDC-1 buck boost charger. The input voltage range is between 3.5 V and 24 V, with a programmable output of 1–4 cells and a charge output current range of 64 mA to 8.128 A. This EVM does not include the EV2400 interface device; the EV2400 must be ordered separately to evaluate the bq2570x EVM.

Contents

1	Introduction	2
1.1	EVM Features	2
1.2	General Description	2
2	Test Summary	5
2.1	Definitions	5
2.2	Equipment	5
2.3	Equipment Setup.....	6
2.4	Procedure	8
3	Bill of Materials, Board Layout, and Schematics	9
3.1	Bill of Materials	9
3.2	Board Assembly Layout	12
3.3	Schematic	13

List of Figures

1	EV2400 Connections	6
2	Original Test Setup for PWR732 (bq2570x EVM)	7
3	Main Window of the bq2570x Evaluation Software	7
4	EN_OTG	8
5	Top Assembly.....	12
6	Bottom Assembly.....	12
7	bq2570x EVM Schematic	13

List of Tables

1	I/O Description	3
2	Controls and Key Parameters Setting	3
3	Recommended Operating Conditions.....	4
4	bq2570x EVM Bill of Materials	9

Trademarks

USB Type-C is a trademark of USB Implementer's Forum, Inc..
 All other trademarks are the property of their respective owners.

1 Introduction

1.1 EVM Features

This EVM supports the following features:

- Evaluation module for the bq2570x devices
- Supports 3.5- to 24-V input source
 - 3.5- to 24-V, 0- to 6-A input operating range and 1–4 cell battery configuration
 - Supports USB2.0, USB 3.0, USB 3.1 (USB Type-C™) and USB_PD
 - Supports USB OTG with 4.48- to 20.8-V adjustable output
 - *Maximum Power Tracking by Input Voltage and Current Regulation*
- Narrow VDC (NVDC) power path management
 - Instant-on works with no battery or deeply discharged battery (PG1.0 needs charge-enable command)
 - Battery supplements system when adapter is fully-loaded
- 800-kHz or 1.2-MHz switching frequency for low profile inductor
- SMBus (bq25700A) or I²C (bq25703A) port for optimal system performance and status reporting
- Power and Current Monitor for CPU Throttling
- Safety
 - Thermal shutdown
 - Input and system overvoltage protection
 - MOSFET overcurrent protection
- Accelerate charge time by battery path impedance compensation
- Charge status outputs for LED or host processor
- Maximum power tracking capability by input voltage regulation
- Test points for key signals available for testing purposes. Easy probe hook-up.
- Jumpers available. Easy-to-change connections.

1.2 General Description

The bq2570x evaluation modules are complete charger modules for evaluating an SMBUS or I²C-controlled buck boost charge using the bq2570x devices.

The bq2570x EVM does not include the EV2400 interface board. To evaluate the bq2570x EVM, order an EV2400 interface board separately.

The bq2570x is a synchronous NVDC-1 battery buck boost charge controller, offering a low component count, high efficiency solution for space-constrained, multi-chemistry battery charging applications.

The NVDC-1 configuration allows the system to be regulated at the battery voltage, but not drop below the system minimum voltage. The system keeps operating even when the battery is completely discharged or removed. When load power exceeds the input source rating, the battery supplement mode prevents the input source from being overloaded.

The bq2570x charges the battery from a wide range of input sources including a 5-V USB adapter to a high-voltage USB PD source and traditional adapters.

During power up, the charger sets the converter to buck, boost, or buck-boost configuration based on the input source and battery conditions. During the charging cycle, the charger automatically transits among buck, boost, and buck-boost configuration without host control.

The bq2570x monitors adapter current, battery current, and system power. The flexibly programmed PROCHOT output goes directly to the CPU for throttle back, when needed.

For more details on register functions, see the data sheets – bq25700A ([SLUSCQ8](#)) and bq25703A ([SLUSCU1](#)).

Table 1 lists the I/O descriptions.

Table 1. I/O Description

Jack	Description
J1-VIN	Input: positive terminal
J1-GND	Input: negative terminal (ground terminal)
J2-ILIM_control	External converter disable; logic high to pull the ILIM pin down
J2-CHRG_OK	CHRG_OK output
J2-ENZ_OTG	External OTG disable pin
J2-CELL_control	External battery removal control; logic high to pull the CELL pin down
J3-3V3	Onboard 3.3-V output
J3-SDA	SMBUS or I ² C SDA
J3-SCL	SMBUS or I ² C SCL
J3-GND	Ground
J4-CMPOUT	CMPOUT pin output
J4-GND	Ground
J4-CMPIN	External CMPIN pin input
J5-BAT	Connected to battery pack output
J5-GND	Ground
J6-SYS	Connected to system output
J6-GND	Ground

Table 2 displays the controls and key parameters settings.

Table 2. Controls and Key Parameters Setting

Jack	Description	Factory Setting
JP1 JP7	Inrush control setting: 1. Bypass inrush control circuit JP1 on: bypasses input FETs Q9 and Q10 external selector JP7 top two connection (pin 2 is connected to pin 3): VBUS pin on ACP 2. Enable inrush control circuit JP1 off: CHRG_OK controls Q9 and Q10 external selector JP7 bottom two connection: VBUS pin on V _{IN}	Bypass inrush control circuit: JP1 installed JP7 top two position installed (pin2 is connected pin3)
JP2 JP3 JP4	CELL setting: 1S: JP2, JP3, JP4 all open, measure CELL pin voltage 1.2 V 2S: JP2 closed, JP3 and JP4 open, measure CELL pin voltage 2.7 V 3S: JP3 closed, JP2 and JP4 open, measure CELL pin voltage 3.5 V 4S: JP2, JP3 closed, JP4 open, measure CELL pin voltage 4.2 V Bat removal, short JP4	2S setting: JP2 installed JP3, JP4 all open
JP5	Jumper on: Pre-bias ILIM_HIZ Jumper off: Ground ILIM_HIZ	Installed
JP6	For input current setting: Jumper on: ILIM_HIZ LOW. Jumper off: Allow pre-bias ILIM_HIZ	Not installed
JP8	Jumper on: On-board LDO to drive the EVM 3V3 Jumper off: disconnect on-board LDO to drive the EVM 3V3	Installed

Table 3 lists the recommended operating conditions.

Table 3. Recommended Operating Conditions

Symbol	Description	MIN	TYP	MAX	Unit
Supply voltage, V_{IN}	Input voltage from ac adapter input	3.5	5/12/19	24	V
Battery voltage, V_{BAT}	Voltage applied at VBAT terminal	0		19.2	V
Supply current, I_{AC}	Maximum input current from ac adapter input	0		3	A
Output current, I_{out}	Output current	0		8	A
Operating junction temperature range, T_J		0		125	°C

2 Test Summary

2.1 Definitions

This procedure details how to configure the PWR732 evaluation board. For the test procedure, the following naming conventions are followed. Refer to the [PWR732 schematic](#) for details.

VXXX:	External voltage supply name (VADP, VBT, VSBT)
LOADW:	External load name (LOADR, LOADI)
V(TPyyy):	Voltage at internal test point TPyyy. For example, V(TP12) means the voltage at TP12.
V(Jxx):	Voltage at jack terminal Jxx.
V(TP(XXX)):	Voltage at test point "XXX". For example, V(ACDET) means the voltage at the test point which is marked as "ACDET".
V(XXX, YYY):	Voltage across point XXX and YYY.
I(JXX(YYY)):	Current going out from the YYY terminal of jack XX.
Jxx(BBB):	Terminal or pin BBB of jack xx
Jxx ON :	Internal jumper Jxx terminals are shorted
Jxx OFF:	Internal jumper Jxx terminals are open
Jxx (-YY-) ON:	Internal jumper Jxx adjacent terminals marked as "YY" are shorted
Measure: → A,B	Check specified parameters A, B. If measured values are not within specified limits, the unit under test has failed.
Observe → A,B	Observe if A, B occurs. If they do not occur, the unit under test has failed.

[Assembly drawings](#) have locations for jumpers, test points, and individual components.

2.2 Equipment

The following list of equipment is required for fully testing the EVM:

1. Power Supplies

A power supply capable of supplying 24 V at 6 A is required. While this part can handle larger voltage and current, it is not necessary for this procedure.

2. Load #1

A 0- to 20-V/0- to 6-A, system DC electronic load and setting as constant voltage load mode.

3. Load #2

A Kepco load: BOP36-6M, DC 0 to ±36 V, 0 to ±6 A (or higher), or equivalent.

4. Meters

Six Fluke 75 multimeters, (equivalent or better) or: Four equivalent voltage meters and two equivalent current meters.

5. Computer

A computer with at least one USB port and a USB cable.

6. EV2400 Communication Kit

7. Software

Download and properly install bqstudio (Version: 1.3.45 or newer) from <http://www.ti.com/tool/bqstudio>.

2.3 Equipment Setup

Use the following guidelines to set up the equipment:

1. Set power supply #1 for 10-V DC, 5-A current limit and then turn off the supply.
2. Connect the output of power supply #1 in series with a current meter to J1 (VIN and GND).
3. Connect a voltage meter across J1 (VIN) and J1 (GND).
4. Connect load #1 in series with a current meter to J6 (VSYS and GND). Connect a voltage meter across J6 (VSYS and GND). Set 1 A at the constant current mode. Turn off load #1.
5. Connect Load #2 in series with a current meter to J5 (VBAT and GND). Connect a voltage meter across J5 (VBAT and GND). Set 7 V at KEPCO load output. Turn off Load #2.

NOTE: Add a 47- μ F capacitor on the BAT pin when testing without real battery.

6. Connect J3 to the EV2400. Connect J3 to the SMBus PORT 1 (bq25700A) or I²C PORT 2 (bq25703A) on the EV2400. The connections are shown in [Figure 1](#).

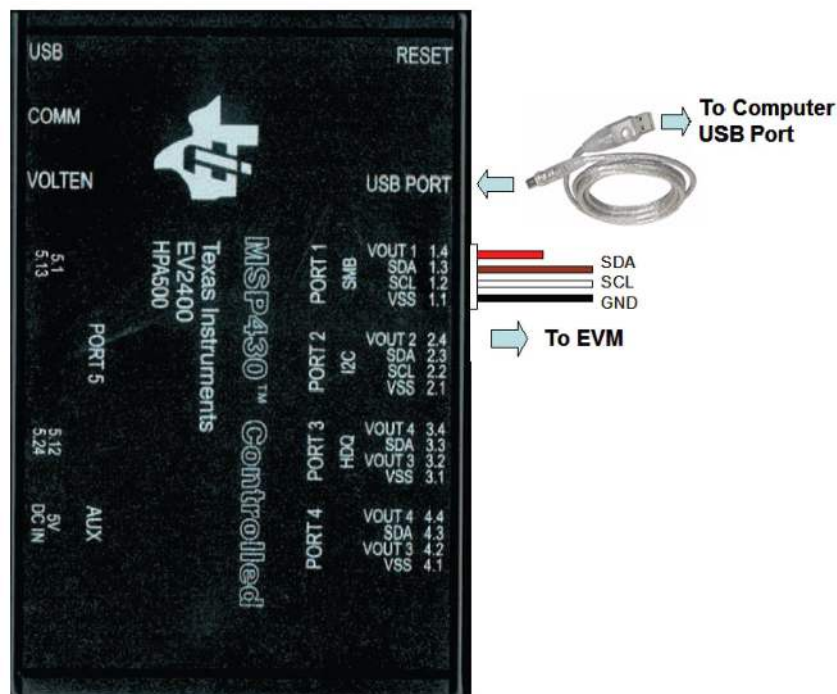

The picture shows the SMBus version EVM connection. If using the bq25703AEVM-732, move the connector to the I²C port.

Figure 1. EV2400 Connections

7. Install jumpers as “JUMPER SET UP”.

After completing these steps , the test setup for PWR732 is as shown in Figure 2.

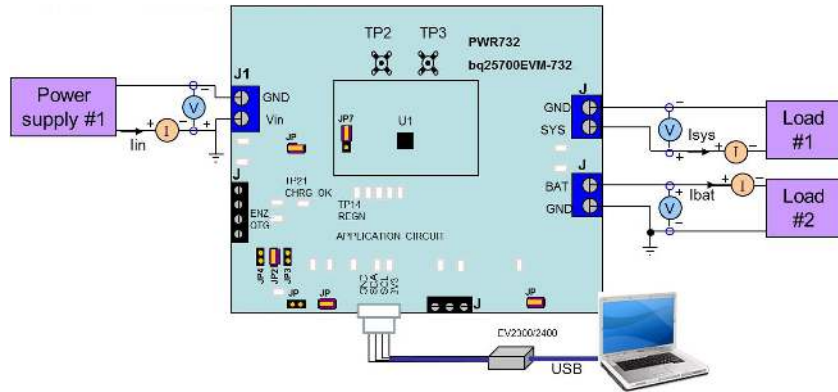
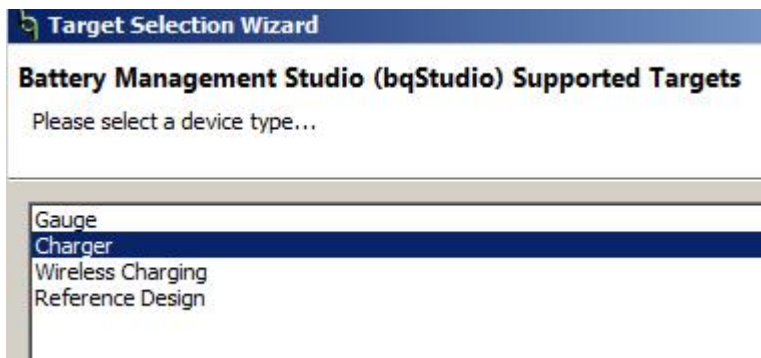

Figure 2. Original Test Setup for PWR732 (bq2570x EVM)

8. Turn on the computer and power supply #1. Open the bqstudio software.
 - a. Select *Charger* and click the **Next** button.



- b. For SMBus bq25700A, select “Charger_1_00-bq25700ASMB.bqz” on the *Select a Target Page*. For I²C bq25703A, select “Charger_1_00-bq25703AI2C.bqz” on the *Select a Target Page*.
 - c. After selecting the target device, change “update mode” from “immediate” to “manual”, click “Read Register” and the following interface is presented.

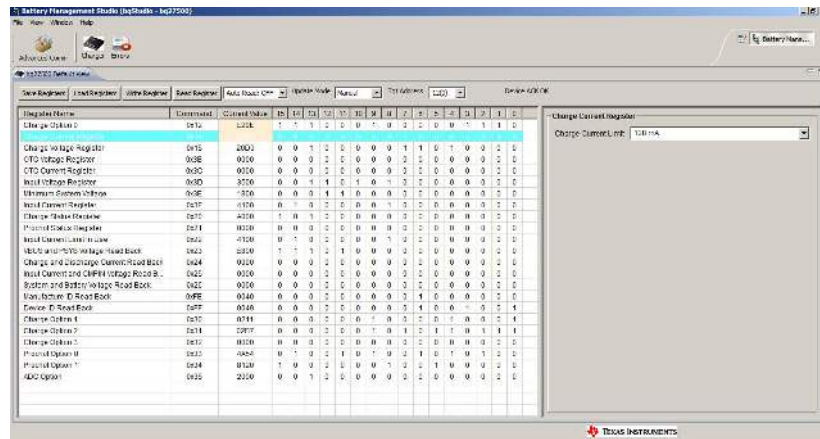

Figure 3. Main Window of the bq2570x Evaluation Software

2.4 Procedure

2.4.1 Charge Function

1. Make sure [Equipment Setup](#) steps are followed.
2. Set Tgt Address to 12(9) for bq25700A or D6(6B) for bq25703A
3. Write "020E" to charge option 0 register 0x12H (bq25700A) or 0x00H (bq25703A).
 Measure → $V(J1(V_{IN})) = 10\text{ V} \pm 0.5\text{ V}$
 Measure → $V(TP28(CHRG_OK)) = 3\text{ V to } 4.5\text{ V}$
 Measure → $V(TP21(REGN)) = 6\text{ V} \pm 1\text{ V}$
 Measure → $V(TP22(ILIM_HIZ)) = 2.2\text{ V}$
4. Write "0800" to charge current 0x14H (bq25700A) or 0x02H (bq25703A). Turn on load #1.
 Measure → $V(J6(SYS)) = 8.4\text{ V} \pm 0.5\text{ V}$
5. Turn on LOAD #2 (VBAT Load).
 Measure → $V(J5(VBAT)) = 7\text{ V} \pm 0.5\text{ V}$
 Measure → $I(J5(VBAT)) = 2\text{ A} \pm 0.5\text{ V}$

2.4.2 OTG Function

Use the following for OTG function settings:

1. Set *EN_OTG* high on J2 (*EN_OTG*) or short TP37 to TP35 (*EN_OTG*).
2. Connect a 7-V power supply to the VBAT load. Remove the V_{IN} power supply from J1. (Connection must be physically removed from board).
3. Write the *Charge Voltage Register* to 0x20D0.
4. Write "0200" to the OTG voltage register. Write "4000" to the OTG current registers.
5. Select *EN_OTG* in *Charge Option 3*.
 Measure → $V(J1(V_{IN})) = 5\text{ V} \pm 1\text{ V}$

Register Name	Command	Current Value	15	14	13	12	11	10	9	8	7	6	5	4	3	2	1	0
Charge Option 0	0x12	0206	0	0	0	0	0	0	1	0	0	0	0	0	0	1	1	0
Charge Current Register	0x14	0800	0	0	0	0	1	0	0	0	0	0	0	0	0	0	0	0
Charge Voltage Register	0x15	0000	0	0	0	0	0	0	0	0	0	0	0	0	0	0	0	0
OTG Voltage Register	0x3B	0000	0	0	0	0	0	0	0	0	0	0	0	0	0	0	0	0
OTG Current Register	0x3C	0000	0	0	0	0	0	0	0	0	0	0	0	0	0	0	0	0
Input Voltage Register	0x3D	0000	0	0	0	0	0	0	0	0	0	0	0	0	0	0	0	0
Minimum System Voltage	0x3E	0000	0	0	0	0	0	0	0	0	0	0	0	0	0	0	0	0
Input Current Register	0x3F	4100	0	1	0	0	0	0	0	1	0	0	0	0	0	0	0	0
Charge Status Register	0x20	A000	1	0	1	0	0	0	0	0	0	0	0	0	0	0	0	0
Prochot Status Register	0x21	0000	0	0	0	0	0	0	0	0	0	0	0	0	0	0	0	0
Input Current Limit In Use	0x22	4100	0	1	0	0	0	0	0	1	0	0	0	0	0	0	0	0
VBUS and PSYS Voltage Read Back	0x23	0000	0	0	0	0	0	0	0	0	0	0	0	0	0	0	0	0
Charge and Discharge Current Read Back	0x24	0000	0	0	0	0	0	0	0	0	0	0	0	0	0	0	0	0
Input Current and CMPIN Voltage Read B...	0x25	0000	0	0	0	0	0	0	0	0	0	0	0	0	0	0	0	0
System and Battery Voltage Read Back	0x26	0000	0	0	0	0	0	0	0	0	0	0	0	0	0	0	0	0
Manufacture ID Read Back	0xFE	0040	0	0	0	0	0	0	0	0	0	1	0	0	0	0	0	0
Device ID Read Back	0xFF	0049	0	0	0	0	0	0	0	0	0	1	0	0	1	0	0	1
Charge Option 1	0x30	0210	0	0	0	0	0	0	1	0	0	0	0	1	0	0	0	0
Charge Option 2	0x31	02B7	0	0	0	0	0	0	1	0	1	0	1	1	0	1	1	1
Charge Option 3	0x32	1000	0	0	0	1	0	0	0	0	0	0	0	0	0	0	0	0

Charge Option 3

EN_HIZ

RESET_REG

RESET_VINDPM

EN_OTG

EN_ICO

EN_PUMPX

PUMPX_UP

PUMPX_DN

Figure 4. EN_OTG

3 Bill of Materials, Board Layout, and Schematics

This section contains the EVM BOM, board layout images, and schematics.

3.1 Bill of Materials

Table 4 lists the bq2570x EVM bill of materials.

Table 4. bq2570x EVM Bill of Materials

Designator	Qty	Value	Description	Package Reference	Part Number	Manufacturer	Alternate Part Number	Alternate Manufacturer
!PCB1	1		Printed Circuit Board		PWR732	Any	-	-
C3, C4, C5, C6, C7, C8, C9, C10, C23, C24, C44, C45	12	10uF	CAP, CERM, 10 µF, 25 V, +/- 10%, X5R, 0805	0805	GRM21BR61E106KA73L	Murata		
C12	1	0.01uF	CAP, CERM, 0.01 µF, 25 V, +/- 10%, X7R, 0603	0603	GRM188R71E103KA01D	Murata		
C15, C16	2	0.047uF	CAP, CERM, 0.047uF, 25V, +/-10%, X7R, 0603	0603	GRM188R71E473KA01D	Murata		
C17	1	1000pF	CAP, CERM, 1000 pF, 25 V, +/- 5%, X7R, 0402	0402	C0402C102J3RACTU	Kemet		
C18, C29	2	1uF	CAP, CERM, 1uF, 25V, +/-10%, X7R, 0603	0603	GRM188R71E105KA12D	Murata		
C19, C20	2	150pF	CAP, CERM, 150 pF, 50 V, +/- 5%, C0G/NP0, 0603	0603	C0603C151J5GACTU	Kemet		
C22, C27, C38, C39	4	0.1uF	CAP, CERM, 0.1uF, 25V, +/-10%, X7R, 0603	0603	GRM188R71E104KA01D	Murata		
C25	1	0.47uF	CAP, CERM, 0.47 µF, 16 V, +/- 10%, X7R, 0805	0805	C0805C474K4RACTU	Kemet		
C26	1	10uF	CAP, CERM, 10 µF, 25 V, +/- 10%, X7R, 1206	1206	GRM31CR71E106KA12L	Murata		
C28	1	1uF	CAP, CERM, 1 µF, 25 V, +/- 10%, X7R, 0603	0603	GRM188R71E105KA12D	Murata		
C30	1	2.2uF	CAP, CERM, 2.2 µF, 35 V, +/- 10%, X5R, 0603	0603	GRM188R6YA225KA12D	Murata		
C31	1	33pF	CAP, CERM, 33 pF, 50 V, +/- 5%, C0G/NP0, 0402	0402	GRM1555C1H330JA01D	Murata		
C32	1	680pF	CAP, CERM, 680 pF, 50 V, +/- 5%, C0G/NP0, 0402	0402	GRM1555C1H681JA01D	Murata		
C33	1	1800pF	CAP, CERM, 1800 pF, 50 V, +/- 10%, X7R, 0402	0402	GRM155R71H182KA01D	Murata		
C34	1	15pF	CAP, CERM, 15 pF, 50 V, +/- 5%, C0G/NP0, 0402	0402	GRM1555C1H150JA01D	Murata		
C35, C36, C37	3	100pF	CAP, CERM, 100pF, 50V, +/-5%, C0G/NP0, 0603	0603	C0603C101J5GAC	Kemet		
C46, C47	2	0.033uF	CAP, CERM, 0.033 µF, 25 V, +/- 10%, X7R, 0603	0603	GRM188R71E333KA01D	Murata		
C48	1	47uF	CAP, Tantalum Polymer, 47 µF, 20 V, +/- 20%, 0.055 ohm, 7343-20 SMD	7343-20	20TQC47MYF	Panasonic		
D2, D3, D5	3	30V	Diode, Schottky, 30V, 0.2A, SOD-323	SOD-323	BAT54HT1G	ON Semiconductor		
D4	1	Green	LED, Green, SMD	1.6x0.8x0.8mm	LTST-C190GKT	Lite-On		
H1, H2, H3, H4	4		Bumpon, Hemisphere, 0.44 X 0.20, Clear	Transparent Bumpon	SJ-5303 (CLEAR)	3M		
J1, J5, J6	3		TERMINAL BLOCK 5.08MM VERT 2POS	TERM_BLK, 2pos, 5.08mm	ED120/2DS	On-Shore Technology, Inc.		
J2	1		Terminal Block, 6A, 3.5mm Pitch, 4-Pos, TH	14x8.2x6.5mm	ED555/4DS	On-Shore Technology		
J3	1		Header, 100mil, 4x1, R/A, TH	4x1 R/A Header	22-05-3041	Molex		
J4	1		Terminal Block, 6A, 3.5mm Pitch, 3-Pos, TH	10.5x8.2x6.5mm	ED555/3DS	On-Shore Technology, Inc.		
JP1, JP2, JP3, JP4, JP5, JP6, JP8	7		Header, 100mil, 2x1, Gold plated, TH	Header, 2x1, 100mil	5-146261-1	TE Connectivity		

Table 4. bq2570x EVM Bill of Materials (continued)

Designator	Qty	Value	Description	Package Reference	Part Number	Manufacturer	Alternate Part Number	Alternate Manufacturer
JP7	1		Header, 100mil, 3x1, Tin, TH	Header, 3 PIN, 100mil, Tin	PEC03SAAN	Sullins Connector Solutions		
L1	1	2.2uH	Inductor, Wirewound, Powdered Iron, 2.2 µH, 8.5 A, 0.0203 ohm, SMD	9.2x8.5mm	74437356022	Würth Elektronik	IHLP3232CZER2R2M01	Vishay-Dale
LBL1	1		Thermal Transfer Printable Labels, 0.650" W x 0.200" H - 10,000 per roll	PCB Label 0.650"H x 0.200"W	THT-14-423-10	Brady	-	-
Q1, Q2, Q3, Q4	4	30V	MOSFET, N-CH, 30 V, 12 A, SON 3.3x3.3mm	SON 3.3x3.3mm	CSD17551Q3A	Texas Instruments		None
Q5, Q6	2	-30V	MOSFET, P-CH, -30 V, -8.5 A, 8-PowerVDFN	8-PowerVDFN	DMP3035SFG-7	Diodes Inc.	DMG7401SFG-7	Diodes, Inc.
Q7	1	-20V	MOSFET, P-CH, -20 V, -15 A, SON 3.3x3.3mm	SON 3.3x3.3mm	CSD25402Q3A	Texas Instruments		None
Q9	1	50 V	Transistor, NPN/PNP Pair, 50 V, 0.05 A, SC-74R	SC-74R	DCX124EK-7-F	Diodes Inc.		
Q10, Q12	2	60V	MOSFET, N-CH, 60V, 0.26A, SOT-23	SOT-23	2N7002ET1G	ON Semiconductor		None
Q11	1	60V	MOSFET, N-CH, 60 V, 0.26 A, SOT-23	SOT-23	2N7002ET1G	ON Semiconductor		None
R2, R8	2	0.01	RES, 0.01 ohm, 1%, 1W, 1206	1206	WSP1206R0100FEA	Vishay-Dale		
R3, R4	2	3.9	RES, 3.9 ohm, 5%, 0.25W, 1206	1206	CRCW12063R90JNEA	Vishay-Dale		
R9, R28	2	100k	RES, 100 k, 1%, 0.1 W, 0603	0603	RC0603FR-07100KL	Yageo America		
R10, R38	2	10.0	RES, 10.0 ohm, 1%, 0.25W, 1206	1206	ERJ-8ENF10R0V	Panasonic		
R11, R12	2	4.99	RES, 4.99, 1%, 0.1 W, 0603	0603	CRCW06034R99FKEA	Vishay-Dale		
R13	1	1.0	RES, 1.0, 5%, 0.125 W, 0805	0805	CRCW08051R00JNEA	Vishay-Dale		
R14	1	20k	RES, 20 k, 5%, 0.1 W, 0603	0603	CRCW060320K0JNEA	Vishay-Dale		
R15, R16	2	10	RES, 10, 5%, 0.1 W, 0603	0603	CRCW060310R0JNEA	Vishay-Dale		
R17	1	10k	RES, 10 k, 5%, 0.1 W, 0603	0603	CRCW060310K0JNEA	Vishay-Dale		
R18	1	10.0	RES, 10.0 ohm, 1%, 0.1W, 0603	0603	CRCW060310R0FKEA	Vishay-Dale		
R19, R26	2	383k	RES, 383 k, 1%, 0.1 W, 0603	0603	CRCW0603383KFKEA	Vishay-Dale		
R20	1	120k	RES, 120 k, 1%, 0.1 W, 0603	0603	RC0603FR-07120KL	Yageo America		
R21	1	64.9k	RES, 64.9 k, 1%, 0.1 W, 0603	0603	RC0603FR-0764K9L	Yageo America		
R22	1	40.2k	RES, 40.2 k, 1%, 0.063 W, 0402	0402	CRCW040240K2FKED	Vishay-Dale		
R23	1	10.0k	RES, 10.0 k, 1%, 0.063 W, 0402	0402	CRCW040210K0FKED	Vishay-Dale		
R24	1	280k	RES, 280 k, 1%, 0.1 W, 0603	0603	CRCW0603280KFKEA	Vishay-Dale		
R25	1	10.0k	RES, 10.0 k, 1%, 0.1 W, 0603	0603	CRCW060310K0FKEA	Vishay-Dale		
R27	1	220k	RES, 220 k, 1%, 0.1 W, 0603	0603	RC0603FR-07220KL	Yageo America		
R29, R42	2	300k	RES, 300 k, 1%, 0.1 W, 0603	0603	CRCW0603300KFKEA	Vishay-Dale		
R30	1	137k	RES, 137 k, 1%, 0.1 W, 0603	0603	RC0603FR-07137KL	Yageo America		
R31	1	100	RES, 100, 1%, 0.1 W, 0603	0603	CRCW0603100RFKEA	Vishay-Dale		
R32, R33, R35, R39	4	10.0k	RES, 10.0k ohm, 1%, 0.1W, 0603	0603	CRCW060310K0FKEA	Vishay-Dale		
R34	1	30.1k	RES, 30.1k ohm, 1%, 0.1W, 0603	0603	CRCW060330K1FKEA	Vishay-Dale		
R36	1	2.00k	RES, 2.00k ohm, 1%, 0.1W, 0603	0603	CRCW06032K00FKEA	Vishay-Dale		
R41	1	2.0Meg	RES, 2.0 M, 5%, 0.1 W, 0603	0603	CRCW06032M00JNEA	Vishay-Dale		
SH-JP1, SH-JP2, SH-JP3, SH-JP4, SH-JP5, SH-JP6, SH-JP7, SH-JP8	8	1x2	Shunt, 100mil, Gold plated, Black	Shunt	969102-0000-DA	3M	SNT-100-BK-G	Samtec

Table 4. bq2570x EVM Bill of Materials (continued)

Designator	Qty	Value	Description	Package Reference	Part Number	Manufacturer	Alternate Part Number	Alternate Manufacturer
TP1, TP6, TP7, TP10, TP11, TP13, TP14	7	White	Test Point, Miniature, White, TH	White Miniature Testpoint	5002	Keystone		
TP2, TP3, TP4, TP5, TP9, TP12, TP15, TP16, TP17, TP18, TP19, TP20, TP21, TP22, TP23, TP24, TP25, TP26, TP27, TP28, TP29, TP30, TP31, TP32, TP33, TP34, TP35, TP36, TP37, TP38, TP39, TP40	32	SMT	Test Point, Miniature, SMT	Testpoint_Keystone_Miniature	5015	Keystone		
U1	1		SMBus Multi-Chemistry Battery Buck-Boost Charge Controller With System Power Monitor and Processor Hot Monitor, RSN0032B (WQFN-32)	RSN0032B	bq25700ARSNR for bq25700AEVM-732 or bq25703ARSNR for bq25703AEVM-732	Texas Instruments	BQ25700ARSNT	Texas Instruments
U2	1		100 mA, Quasi Low-Dropout Linear Voltage Regulator, 3-pin SOT-23, Pb-Free	MF03A	LM3480IM3-3.3/NOPB	Texas Instruments		
Z1	1	26V	Diode, TVS, Bi, 26 V, 400 W, SMA	SMA	SMAJ26CA	Littelfuse		
C1	0	15pF	CAP, CERM, 15 pF, 50 V, +/- 5%, C0G/NP0, 0603	0603	C0603C150J5GACTU	Kemet		
C2	0	47uF	CAP, Aluminum Polymer, 47 µF, 25 V, +/- 20%, 0.03 ohm, F61 SMD	F61	25SVPF47M	Panasonic		
C11	0	0.01uF	CAP, CERM, 0.01 µF, 25 V, +/- 10%, X7R, 0603	0603	GRM188R71E103KA01D	Murata		
C13, C14	0	330pF	CAP, CERM, 330 pF, 50 V, +/- 10%, X7R, 0603	0603	GRM188R71H331KA01D	Murata		
C21, C40, C42, C43	0	10uF	CAP, CERM, 10 µF, 25 V, +/- 10%, X5R, 0805	0805	GRM21BR61E106KA73L	Murata		
C41	0	0.01uF	CAP, CERM, 0.01µF, 25V, +/-10%, X7R, 0603	0603	GRM188R71E103KA01D	Murata		
D1	0	20V	Diode, Schottky, 20 V, 2 A, SMA	SMA	B220A-13-F	Diodes Inc.		
FID1, FID2, FID3, FID4, FID5, FID6	0		Fiducial mark. There is nothing to buy or mount.	Fiducial	N/A	N/A		
R1	0	0	RES, 0 ohm, 5%, 0.1W, 0603	0603	CRCW06030000Z0EA	Vishay-Dale		
R5, R6	0	56	RES, 56, 5%, 0.1 W, 0603	0603	CRCW060356R0JNEA	Vishay-Dale		
R37	0	10.0k	RES, 10.0k ohm, 1%, 0.1W, 0603	0603	CRCW060310K0FKEA	Vishay-Dale		
Notes:		Unless otherwise noted in the Alternate Part Number and/or Alternate Manufacturer columns, all parts may be substituted with equivalents.						

3.2 Board Assembly Layout

Figure 5 and Figure 6 illustrate the board assembly layout images.

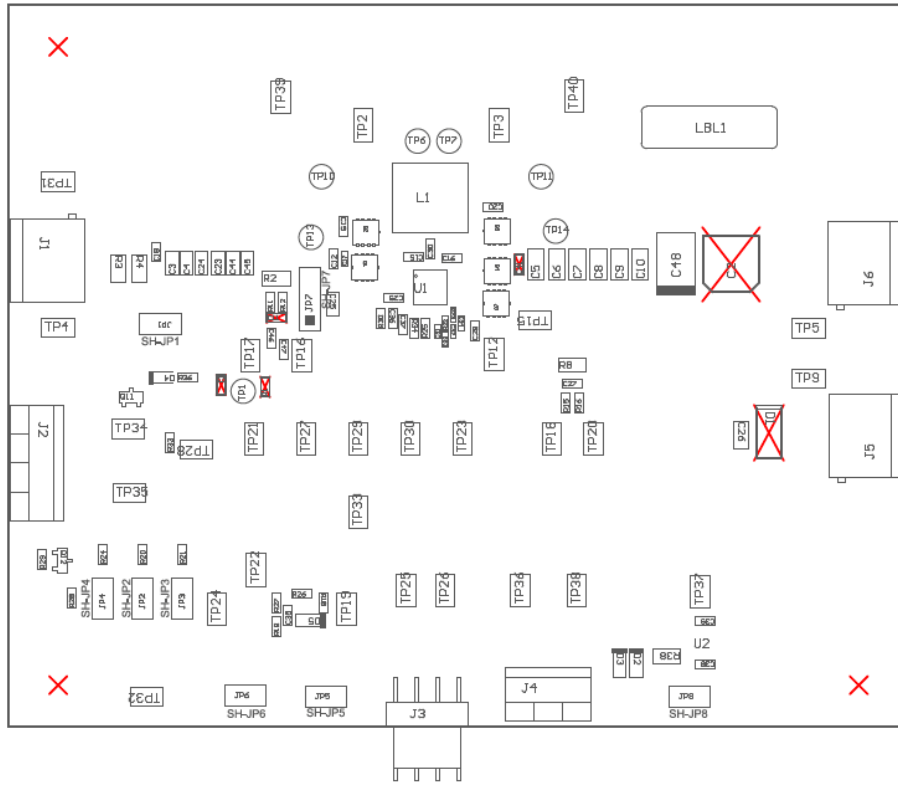

Figure 5. Top Assembly

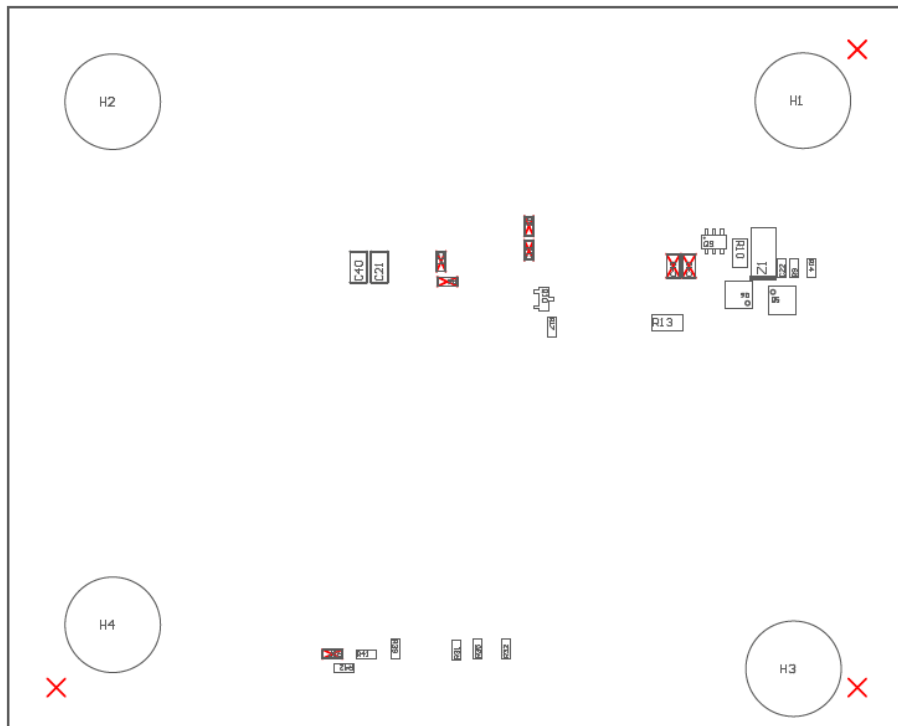
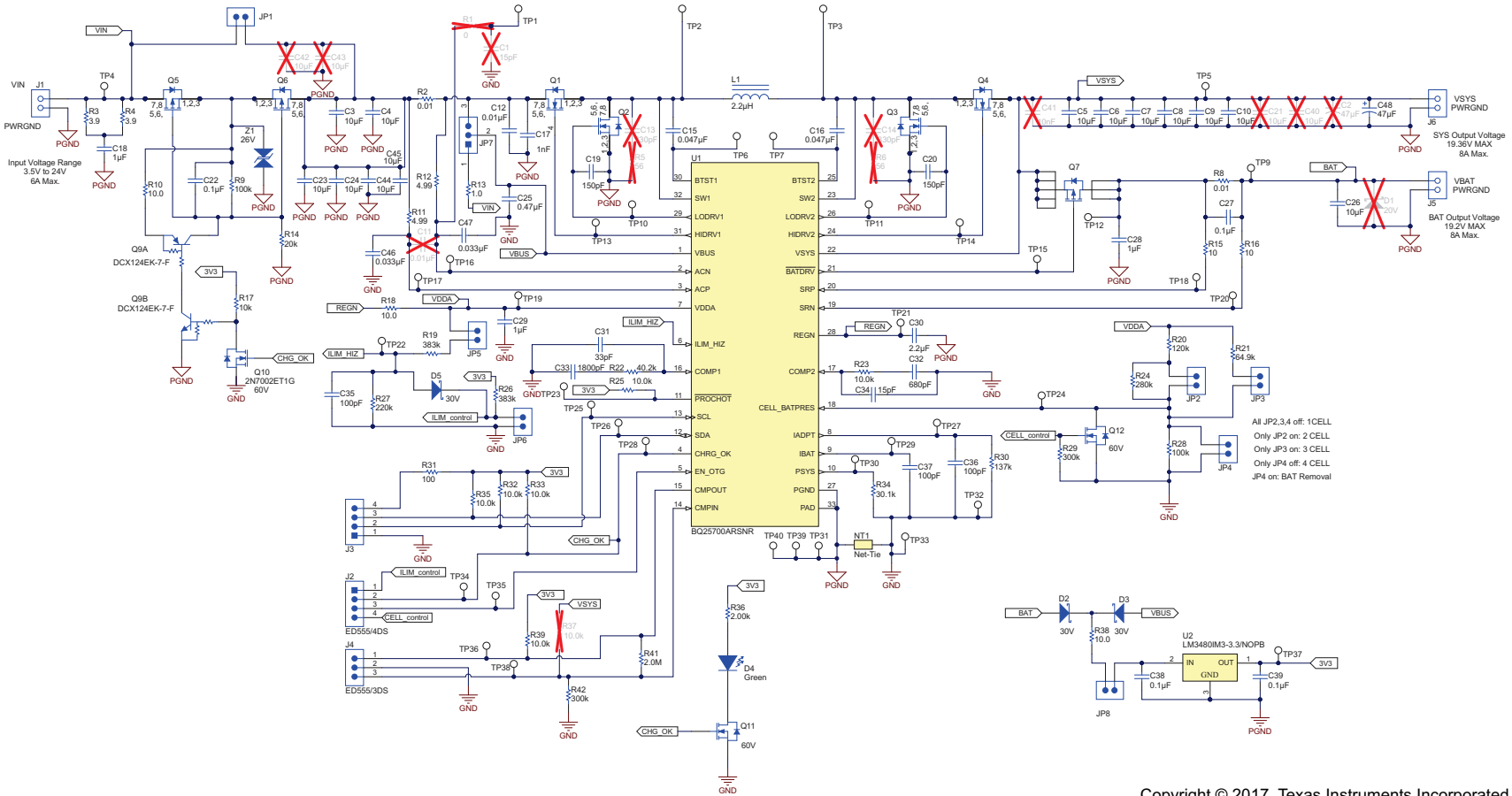

Figure 6. Bottom Assembly

3.3 Schematic

Figure 7 shows the EVM schematic.



Copyright © 2017, Texas Instruments Incorporated

Figure 7. bq2570x EVM Schematic

IMPORTANT NOTICE FOR TI DESIGN INFORMATION AND RESOURCES

Texas Instruments Incorporated ("TI") technical, application or other design advice, services or information, including, but not limited to, reference designs and materials relating to evaluation modules, (collectively, "TI Resources") are intended to assist designers who are developing applications that incorporate TI products; by downloading, accessing or using any particular TI Resource in any way, you (individually or, if you are acting on behalf of a company, your company) agree to use it solely for this purpose and subject to the terms of this Notice.

TI's provision of TI Resources does not expand or otherwise alter TI's applicable published warranties or warranty disclaimers for TI products, and no additional obligations or liabilities arise from TI providing such TI Resources. TI reserves the right to make corrections, enhancements, improvements and other changes to its TI Resources.

You understand and agree that you remain responsible for using your independent analysis, evaluation and judgment in designing your applications and that you have full and exclusive responsibility to assure the safety of your applications and compliance of your applications (and of all TI products used in or for your applications) with all applicable regulations, laws and other applicable requirements. You represent that, with respect to your applications, you have all the necessary expertise to create and implement safeguards that (1) anticipate dangerous consequences of failures, (2) monitor failures and their consequences, and (3) lessen the likelihood of failures that might cause harm and take appropriate actions. You agree that prior to using or distributing any applications that include TI products, you will thoroughly test such applications and the functionality of such TI products as used in such applications. TI has not conducted any testing other than that specifically described in the published documentation for a particular TI Resource.

You are authorized to use, copy and modify any individual TI Resource only in connection with the development of applications that include the TI product(s) identified in such TI Resource. NO OTHER LICENSE, EXPRESS OR IMPLIED, BY ESTOPPEL OR OTHERWISE TO ANY OTHER TI INTELLECTUAL PROPERTY RIGHT, AND NO LICENSE TO ANY TECHNOLOGY OR INTELLECTUAL PROPERTY RIGHT OF TI OR ANY THIRD PARTY IS GRANTED HEREIN, including but not limited to any patent right, copyright, mask work right, or other intellectual property right relating to any combination, machine, or process in which TI products or services are used. Information regarding or referencing third-party products or services does not constitute a license to use such products or services, or a warranty or endorsement thereof. Use of TI Resources may require a license from a third party under the patents or other intellectual property of the third party, or a license from TI under the patents or other intellectual property of TI.

TI RESOURCES ARE PROVIDED "AS IS" AND WITH ALL FAULTS. TI DISCLAIMS ALL OTHER WARRANTIES OR REPRESENTATIONS, EXPRESS OR IMPLIED, REGARDING TI RESOURCES OR USE THEREOF, INCLUDING BUT NOT LIMITED TO ACCURACY OR COMPLETENESS, TITLE, ANY EPIDEMIC FAILURE WARRANTY AND ANY IMPLIED WARRANTIES OF MERCHANTABILITY, FITNESS FOR A PARTICULAR PURPOSE, AND NON-INFRINGEMENT OF ANY THIRD PARTY INTELLECTUAL PROPERTY RIGHTS.

TI SHALL NOT BE LIABLE FOR AND SHALL NOT DEFEND OR INDEMNIFY YOU AGAINST ANY CLAIM, INCLUDING BUT NOT LIMITED TO ANY INFRINGEMENT CLAIM THAT RELATES TO OR IS BASED ON ANY COMBINATION OF PRODUCTS EVEN IF DESCRIBED IN TI RESOURCES OR OTHERWISE. IN NO EVENT SHALL TI BE LIABLE FOR ANY ACTUAL, DIRECT, SPECIAL, COLLATERAL, INDIRECT, PUNITIVE, INCIDENTAL, CONSEQUENTIAL OR EXEMPLARY DAMAGES IN CONNECTION WITH OR ARISING OUT OF TI RESOURCES OR USE THEREOF, AND REGARDLESS OF WHETHER TI HAS BEEN ADVISED OF THE POSSIBILITY OF SUCH DAMAGES.

You agree to fully indemnify TI and its representatives against any damages, costs, losses, and/or liabilities arising out of your non-compliance with the terms and provisions of this Notice.

This Notice applies to TI Resources. Additional terms apply to the use and purchase of certain types of materials, TI products and services. These include; without limitation, TI's standard terms for semiconductor products (<http://www.ti.com/sc/docs/stdterms.htm>), [evaluation modules](#), and [samples](http://www.ti.com/sc/docs/sampterm.htm) (<http://www.ti.com/sc/docs/sampterm.htm>).

Mailing Address: Texas Instruments, Post Office Box 655303, Dallas, Texas 75265
Copyright © 2018, Texas Instruments Incorporated