

Customer Information Sheet

DRAWING No.: Z80-058 SHEET 2 OF 2

IF IN DOUBT - ASK

©

NOT TO SCALE

THIRD ANGLE PROJECTION

ALL DIMENSIONS IN mm

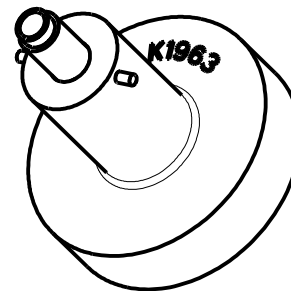
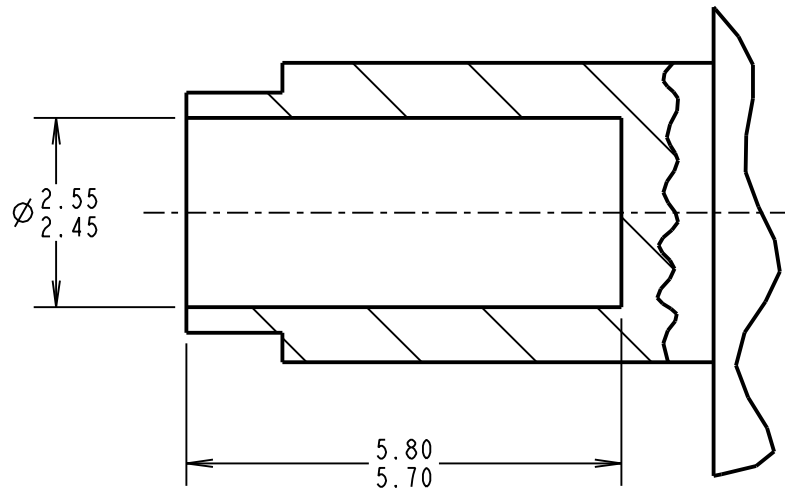
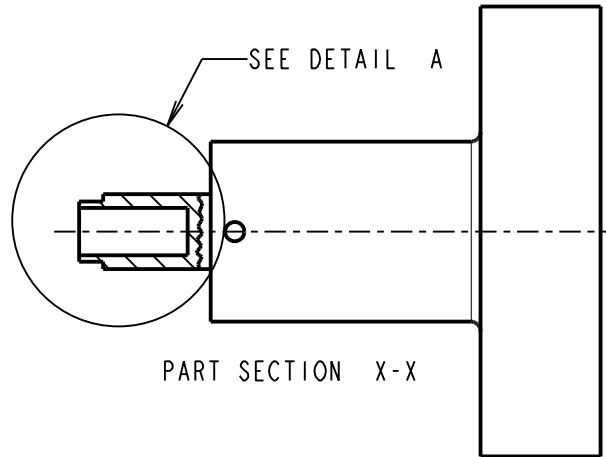
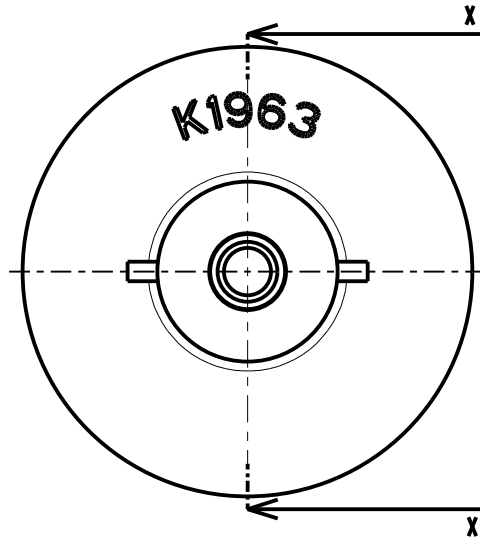

DETAIL A
SCALE 10

- NOTES:
1. INSTRUCTION SHEETS ARE AVAILABLE FOR THIS TOOL. REFER TO INSTRUCTION SHEET IS-01.
 2. FOR USE WITH M80-05500XX, M300-0010045, M300-0020045, M300-1010045 AND M300-1020045 CRIMP CONTACTS.

MSP	3	28.10.15	13083
NAME	ISS.	DATE	C/NOTE
APPROVED:		M.PERREN	
CHECKED:		M.PLESTED	
DRAWN:		S.BENNETT	
CUSTOMER REF.:			
ASSEMBLY DRG:			

HARWIN

www.harwin.com
technical@harwin.com

THIS DRAWING AND ANY INFORMATION OR DESCRIPTIVE MATTER SET OUT HEREON ARE CONFIDENTIAL AND COPYRIGHT PROPERTY OF THE HARWIN GROUP AND MUST NOT BE DISCLOSED, LOANED, COPIED OR USED FOR MANUFACTURING, TENDERING OR FOR ANY OTHER PURPOSE WITHOUT THEIR WRITTEN PERMISSION.

TOLERANCES
X. = ±1mm
X.X = ±0.50mm
X.XX = ±0.10mm
X.XXX = ±0.01mm
ANGLES = ±5°
UNLESS STATED

MATERIAL:

FINISH: CLEAN

S/AREA: mm²

TITLE:

CONTACT CRIMP
POSITIONER

DRAWING NUMBER:

Z80-058

SHT
2 OF 2