

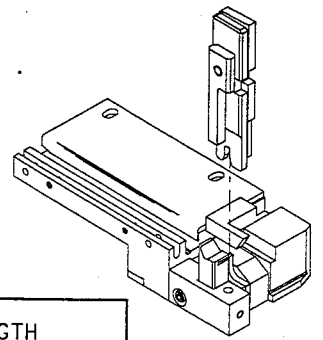

APPLICATION TOOLING TERMINATOR DIE SPECIFICATION SHEET



TERMINAL SPECIFICATION

TERMINAL SERIES	WIRE SIZE		INSULATION DIAMETER		STRIP LENGTH	
	MIN	MAX	ENGLISH	(METRIC)	ENGLISH	(METRIC)
43375-1001	.18	.14	.120 - .180	(3.05 - 4.57)	.156 - .218	(3.96 - 5.54)
			-	(-)	-	(-)
			-	(-)	-	(-)
			-	(-)	-	(-)
			-	(-)	-	(-)
			-	(-)	-	(-)
			-	(-)	-	(-)

TOOLING INFORMATION

ITEM	ORDER NO.	SIZE	ENG. NO.	DESCRIPTION	REQ'D
4	634430002	B	634430002	FRONT CUT-OFF PLUNGER	1
6	634442513	B	634442513	CONDUCTOR PUNCH	1
7	634452562	B	634452562	CONDUCTOR ANVIL	1
8	634464817	B	634464817	INSULATION PUNCH	1
9	634454814	B	634454814	INSULATION ANVIL	1
***	6384052-70		6384052-70	TOOL KIT (ALL THE ABOVE ITEMS)	1

CRIMP SPECIFICATION

WIRE AWG	CRIMP HEIGHT		CRIMP WIDTH (REF.)		PULL FORCE MINIMUM	
	ENGLISH	(METRIC)	ENGLISH	(METRIC)	LBS.	(N)
14	.065 - .069	(1.65 - 1.75)	.098	(2.50)	60	(266)
16	.058 - .062	(1.47 - 1.57)	.098	(2.50)	30	(133)
18	.053 - .056	(1.35 - 1.43)	.098	(2.50)	20	(88.9)
	-	(-)	()	()	()	()
DBL 18	.058 - .062	(1.47 - 1.57)	.098	(2.50)	20	(88.9)

NOTES:

1. WE RECOMMEND AN EXTRA SET OF PERISHABLE TOOLING BE MAINTAINED IN YOUR FACTORY.
2. VERIFY TOOLING ALIGNMENT BY MANUALLY CYCLING THE PRESS AND DIE BEFORE CRIMPING UNDERPOWER. CHECK THAT ALL SCREWS ARE TIGHT.
3. SLUGS, TERMINALS, DIRT AND OIL SHOULD BE KEPT CLEAR OF WORK AREA.
4. CRIMP HEIGHT MAY VARY DEPENDING ON STYLE AND WIRE TYPE.
5. TO PREVENT INJURY - NEVER OPERATE THIS TOOL WITHOUT THE GUARDING SUPPLIED WITH THE PRESS IN PLACE.

DD-MMM-YYY
 HH:MM
 WORK AREA
 REV. BY: JUS
 ECN: 009
 02-0487 KDP
 REVISIONS
 MFG. SH. RE
 LTR.

DIMENSIONS SHOWN (METRIC) INCH

UNLESS OTHERWISE SPECIFIED
TOLERANCES: ANGULAR ± 1/2°

	INCH	METRIC
3 PLACE	± ---	---
2 PLACE	± ---	± ---
1 PLACE	---	± ---

DRAFT WHERE APPLICABLE MUST
REMAIN WITHIN DIMENSIONS

▽ = ▽ = REVISE ONLY ON CAD SYSTEM
 TITLE: TERMINATOR DIE ASSEMBLY
 MOLEX INCORPORATED LISLE, ILL. 60532 U.S.A.
 SHEET NO. 1 of 4 DATE 03/07/95
 PART NO. 6384052-00 DRWG. NO. 6384052-00
 FILE NAME 6384052 580
 THIS DRAWING CONTAINS INFORMATION THAT IS PROPRIETARY TO MOLEX INC. AND SHOULD NOT BE USED WITHOUT WRITTEN PERMISSION.
 DIV. AT SIZE A



APPLICATION TOOLING TERMINATOR DIE SPECIFICATION SHEET

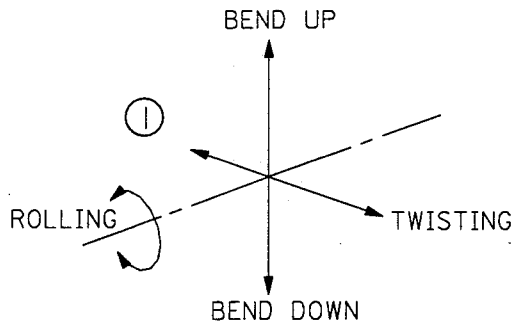
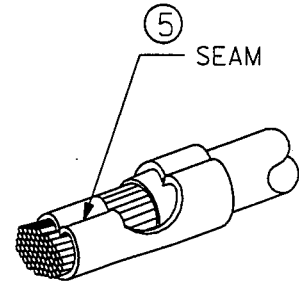
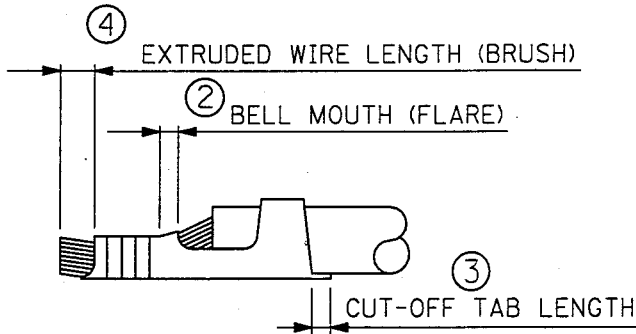
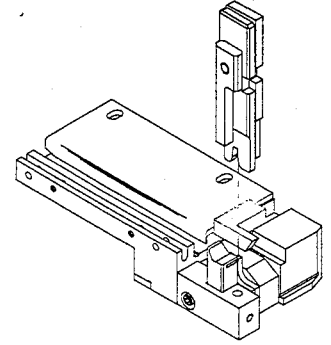

CRIMP SPECIFICATION

NO. OF FIG.	ITEM	REQUIREMENT
1	BEND UP	5° MAX
	BEND DOWN	2° MAX
	TWISTING	5° MAX
	ROLLING	5° MAX
2	BELL MOUTH (FLARE)	0.2 - 0.5mm
3	CUT-OFF TAB LENGTH	0.2mm MAX
4	EXTRUDED WIRE LENGTH (BRUSH)	0.0 - 0.5 mm
5	SEAM	SEAM SHALL NOT BE OPENED AND
		NO WIRE ALLOWED OUT OF THE
		CRIMPING AREA.

DD-MMM-YY
 HH:MM
WORK AREA
 REV. BY: JUS
 ECN: 109
 02-01-97 KDP
 REVISIONS
 MFG. SH. C
 LTR.

DIMENSIONS SHOWN (METRIC) INC

UNLESS OTHERWISE SPECIFIED
TOLERANCES: ANGULAR ± 1/2°

	INCH	METRIC
3 PLACE	± ---	---
2 PLACE	± ---	± ---
1 PLACE	---	± ---

DRAFT WHERE APPLICABLE MUST
REMAIN WITHIN DIMENSIONS

DRWG. BY: SMT CHK'D. BY: VS

APP'D. BY: SCALE: / : /

REVISE ONLY ON CAD SYSTEM

TITLE
TERMINATOR DIE ASSEMBLY

MOLEX INCORPORATED SHEET NO. DATE
 LISLE, ILL. 60532 U.S.A. 2 of 4 03/07/95

PART NO. DRWG. NO.
6384052-00 **6384052-00**

FILE NAME THIS DRAWING CONTAINS INFORMATION THAT IS PROPRIETARY TO MOLEX INC. AND SHOULD NOT BE USED WITHOUT WRITTEN PERMISSION. DIV. SIZE
 6384052 881 AT A



APPLICATION TOOLING TERMINATOR DIE SPECIFICATION SHEET

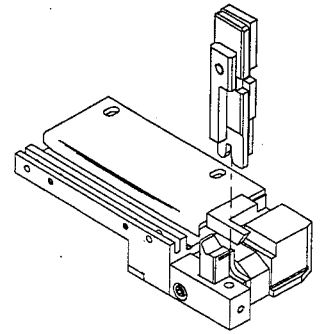

TOOLING INFORMATION

ITEM	ORDER NO.	SIZE	ENG. NO.	DESCRIPTION	REQ'D
4	634430002	B	634430002	FRONT CUT-OFF PLUNGER	1
6	634442513	B	634442513	CONDUCTOR PUNCH	1
7	634452562	B	634452562	CONDUCTOR ANVIL	1
8	634464817	B	634464817	INSULATION PUNCH	1
9	634454814	B	634454814	INSULATION ANVIL	1
***	6384052-70		6384052-70	TOOL KIT (ALL THE ABOVE ITEMS)	1

TERMINATOR ASSEMBLY - PARTS LIST

ITEM	ORDER NO.	SIZE	ENG. NO.	DESCRIPTION	REQ'D
5	634430012	B	634430012	CUT-OFF PLUNGER RETAINER	1
10	11-40-4039	B	8302-5	PLUNGER STRIKER	1
11	634430021	B	634430021	MOUNTING KEY	1
12	638405012	B	638405012	ANVIL MOUNT	1
13	11-40-4068	B	8302-102	DRAG FINGER (L.H.)	1
14	638405014	B	638405014	DRAG FINGER (R.H.)	1
15					
16					
17	638405017	B	638405017	COVER	1
18	11-24-1067	A	4996-4	CUT-OFF PLUNGER SPRING	1
19	638405019	B	638405019	WIRE STOP	1
20	638405020	C	638405020	TERMINAL TRACK	1
21					
22	11-40-4144	B	8302-110	TORSION SPRING, DRAG FINGER	2
23					
24	11-40-4069	B	8302-103	PIVOT PIN	2
25					
26					
27					
28					
29					

	DIMENSIONS SHOWN (METRIC) INCH		▽ =	▼ =	REVISE ONLY ON CAD SYSTEM													
	UNLESS OTHERWISE SPECIFIED TOLERANCES: ANGULAR ± 1/2°		TITLE		TERMINATOR DIE ASSEMBLY													
	<table border="1"> <thead> <tr> <th></th> <th>INCH</th> <th>METRIC</th> </tr> </thead> <tbody> <tr> <td>3 PLACE</td> <td>---</td> <td>---</td> </tr> <tr> <td>2 PLACE</td> <td>---</td> <td>± ---</td> </tr> <tr> <td>1 PLACE</td> <td>---</td> <td>± ---</td> </tr> </tbody> </table>			INCH	METRIC	3 PLACE	---	---	2 PLACE	---	± ---	1 PLACE	---	± ---	MOLEX INCORPORATED LISLE, ILL. 60532 U.S.A.		SHEET NO.	DATE
		INCH	METRIC															
3 PLACE	---	---																
2 PLACE	---	± ---																
1 PLACE	---	± ---																
DRAFT WHERE APPLICABLE MUST REMAIN WITHIN DIMENSIONS		PART NO.		DRWG. NO.														
DRWG. BY SMT	CHK'D. BY VS	6384052-00		6384052-00														
APP'D. BY	SCALE / : /	FILE NAME 6384052-00	THIS DRAWING CONTAINS INFORMATION THAT IS PROPRIETARY TO MOLEX INC. AND SHOULD NOT BE USED WITHOUT WRITTEN PERMISSION.		DIV. AT	SIZE A												

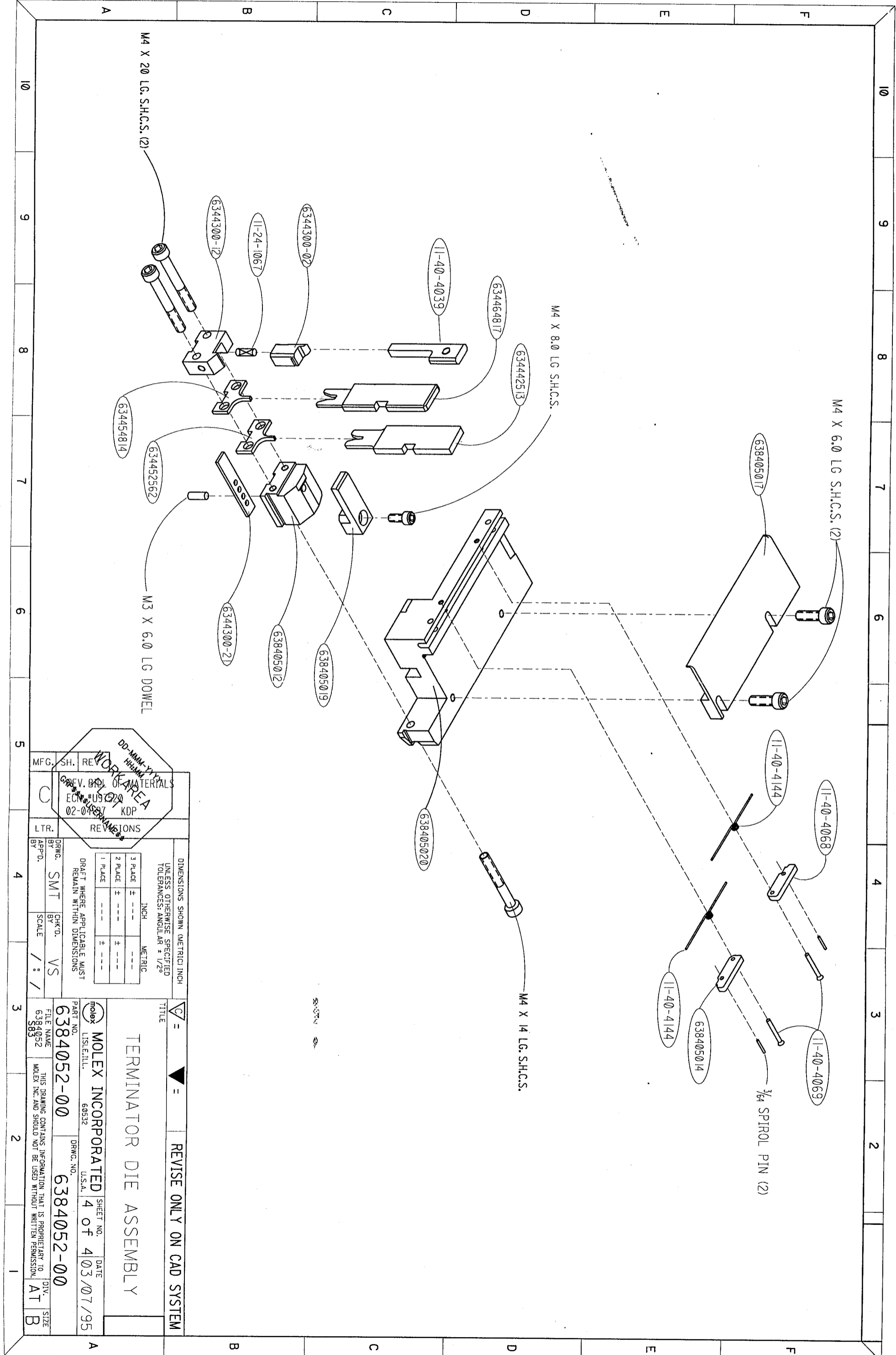

WORK AREA
 DD-MMM-YYYY
 HH:MM
 REV. BY OF MATERIALS
 ECN # US 02
 02-0487 KDP

REVISIONS	
LTR.	REV.
BY	DATE

DRWG. BY: SMT
 APP'D. BY: VS

DIMENSIONS SHOWN (METRIC) INCH	
3 PLACE	±
2 PLACE	±
1 PLACE	±

UNLESS OTHERWISE SPECIFIED
 TOLERANCES: ANGULAR ± 1/2°

DRAFT WHERE APPLICABLE MUST
 REMAIN WITHIN DIMENSIONS

TERMINATOR DIE ASSEMBLY

MOLEX INCORPORATED
 U.S.A.

FILE NAME: 6384052
 LSL:ILL.

PART NO.: 6384052-00
 DRWG. NO.: 6384052-00

SHEET NO.: 4 OF 4
 DATE: 03/07/95

REVISIONS: REVISE ONLY ON CAD SYSTEM

CRIMP