

NOTES:

1. MATERIALS AND FINISHES:  
 BODY, REAR BODY -BRASS, NICKEL PLATING  
 CONTACT - BRASS, GOLD PLATING  
 INSULATOR - PTFE  
 COUPLING NUT- BRASS, NICKEL PLATING  
 CAP- BRASS, NICKEL PLATING  
 FERRULE- COPPER, NICKEL PLATING

2. ELECTRICAL:  
 A. IMPEDANCE: 50 OHM  
 B. FREQUENCY RANGE: DC - 6 GHz  
 C. VSWR(RETURN LOSS): -23 dB MAX

3. MECHANICAL:  
 A. DURABILITY: 500 CYCLES MIN.  
 B. TEMPERATURE RANGE: -65 C TO +165 C

4. PACKAGING:  
 A. QUANTITY: SINGLE PACK  
 B. MARKING: BAG TO BE MARKED  
 "AMPHENOLRF, 82-6489 AND DATE CODE"

5. RECOMMENDED CABLE ASSEMBLY INSTRUCTIONS:  
 A. TRIM CABLE AS SHOWN.  
 B. SLIDE FERRULE AND REAR INSULATOR ONTO CABLE.  
 C. INSERT CABLE WITH FOIL ENTERING CONNECTOR AND BRAID OVER KNURL.  
 D. SOLDER CABLE CENTER CONDUCTOR TO CONTACT.  
 E. CRIMP FERRULE OVER BRAID WITH 0.429" HEX DIE.

6. CAP ASSEMBLY INSTRUCTIONS:  
 A. PLACE O-RING ON CAP AS SHOWN.  
 B. ASSEMBLE CAP TO BODY WITH 6-10 IN-LBS TORQUE.

7. RECOMMENDED COUPLING TORQUE : 6-10 IN-LBS.

8. SHOWS CABLE ENTRY DIMENSIONS.

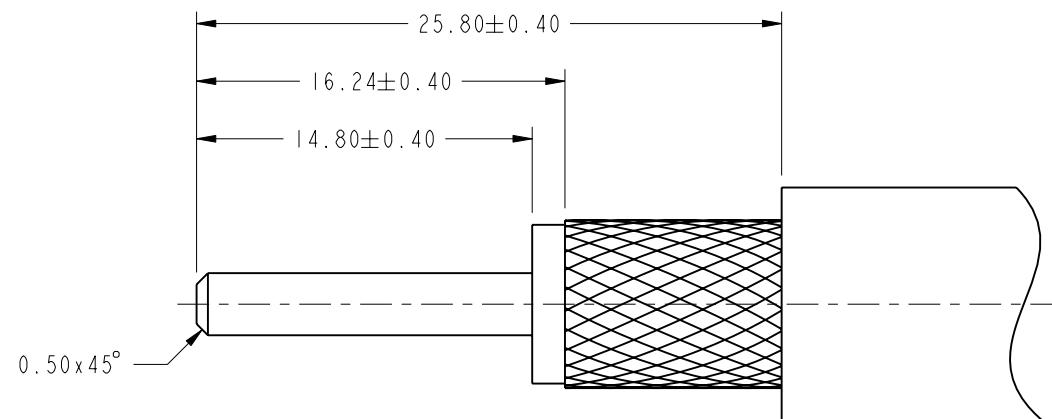

**RECOMMENDED  
CABLE STRIPPING DIMENSIONS**

THIRD ANGLE PROJ.

REVISIONS

REV	DESCRIPTION	DATE	ECO	APPR
A	RELEASE TO MFG	4/26/12	49027	DD
B	ADDED ARC LOGO TO COUPLING NUT\RD-DMI3022001R3	1-Mar-13	49418	RM
C	BODY WAS CHANGED /RD-DMI6070801S7	19-Jul-16	01865	KCE

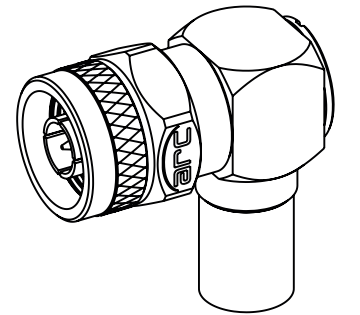
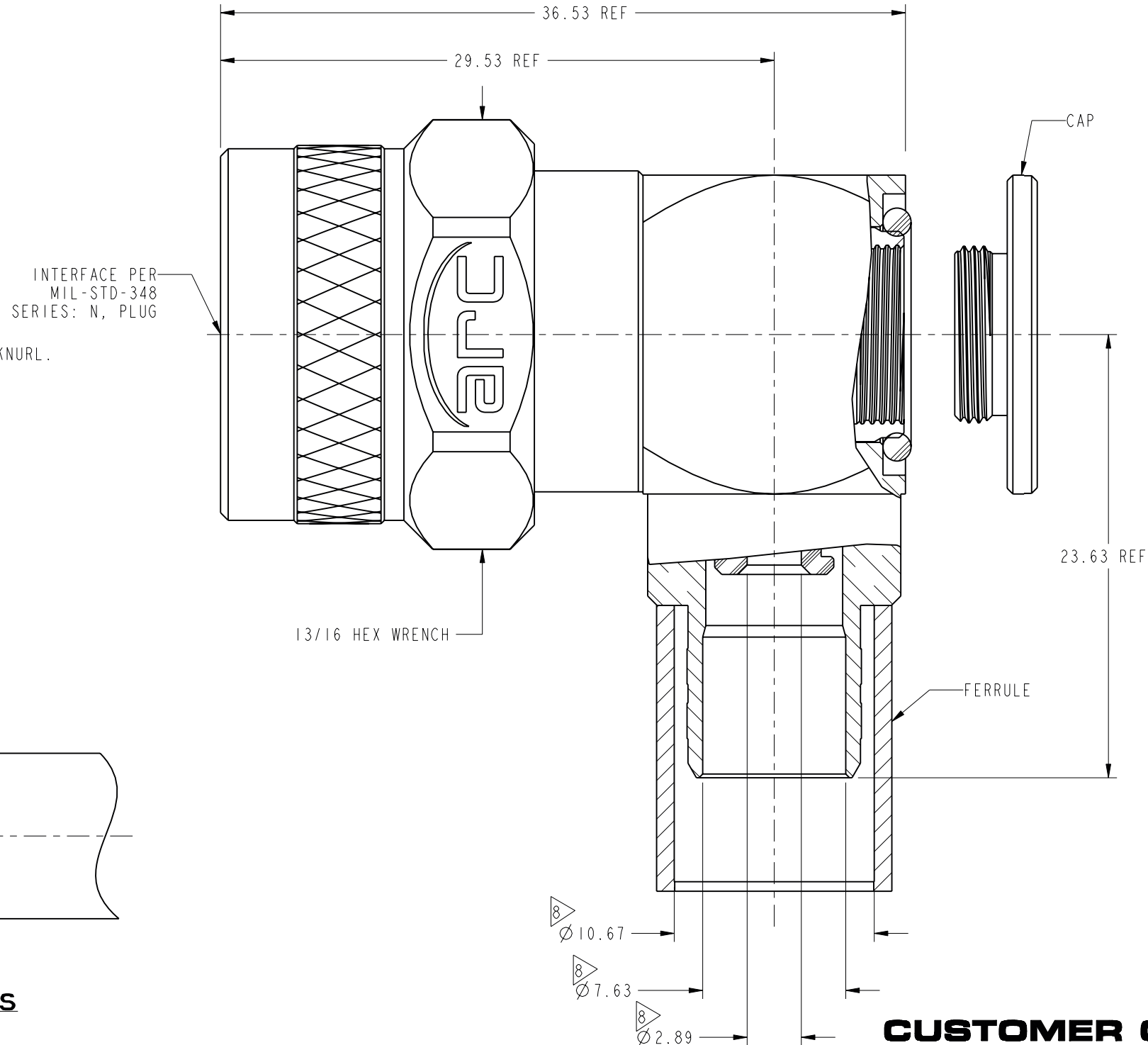

SCALE 1.000

**CUSTOMER OUTLINE DRAWING**

ALL OTHER SHEETS ARE FOR INTERNAL USE ONLY

UNLESS OTHERWISE SPECIFIED, DIMENSIONS ARE IN METRIC AND TOLERANCES ARE: <0.5mm ± 0.05mm    0.5 - 6mm ± 0.1mm    6 - 30mm ± 0.2mm    30 - 120mm ± 0.3mm    ANGLES ± 1°	MATERIAL	DRAWN	DATE	TITLE N PLUG R/A IP-67 FOR LMR-400-CABLE		Amphenol RF Danbury CT USA, Tainan, Taiwan, Shenzhen, China www.amphenolrf.com	
	SEE NOTES	STAR	19-Jul-16				
NOTICE - These drawings, specifications, or other data (1) are, and remain the property of Amphenol corp. (2) must be returned upon request; and (3) are confidential and not to be disclosed to any person other than those to whom they are given by Amphenol Corp. the furnishing of these drawings, specifications, or other data by Amphenol Corp., or to any other person to anyone for any purpose is not to be regarded by implication or otherwise in any manner licensing, granting rights to permitting such holder or any other person to manufacture, use or sell any product, process or design, patented or otherwise, that may in any way be related to or disclosed by said drawings, specifications, or other data.	REFERENCE	ENGINEER	DATE	SCALE: 3.5:1.0    SHEET 2 OF 2		DRAWING NO. 82-6489 ITEM NO. 82-6489 PART NO. 82-6489	
	EAR # 4180	KARTHIK R	28-Mar-12				
	CONFIGURATION LEVEL: In Work	APPROVED	DATE		DWG SIZE	REV	
FINISH		S.HSIEH	20-Jul-16	B	C		