

125V Octal Series Diode Pairs Array with Redundancy

Description

The LX7710 is a diode array that features high breakdown voltage diodes with ESD protection and built-in redundancy. The array contains 8 series connected diode pairs, and is intended for power ORing applications. The series connected diodes are intended to be redundant should one of the diodes fail in a short circuit. Individual diodes within the array have 125V working voltage and can handle up to 700mA of continuous current. ESD protection is also included; the two series ESD diodes have a working voltage of 100V each for a total of 200V. The LX7710 is available in a 20 pin ceramic SOIC package and is QML-V and QML-Q certified.

Features

- 125V Minimum Breakdown Voltage Even If One Diode in Any String Happens to Fail (redundant)
- 700mA Current Capability per Diode
- Low Leakage Current
- ESD Protected
- Rad-tolerant to a Minimum 100krad(Si) TID and SEL Immunity to a Minimum of 87MeV cm²/mg

Applications

- Power ORing
- Redundant Power Sourcing
- Aerospace Satellite Manufacturers
- Military Power Electronics Control

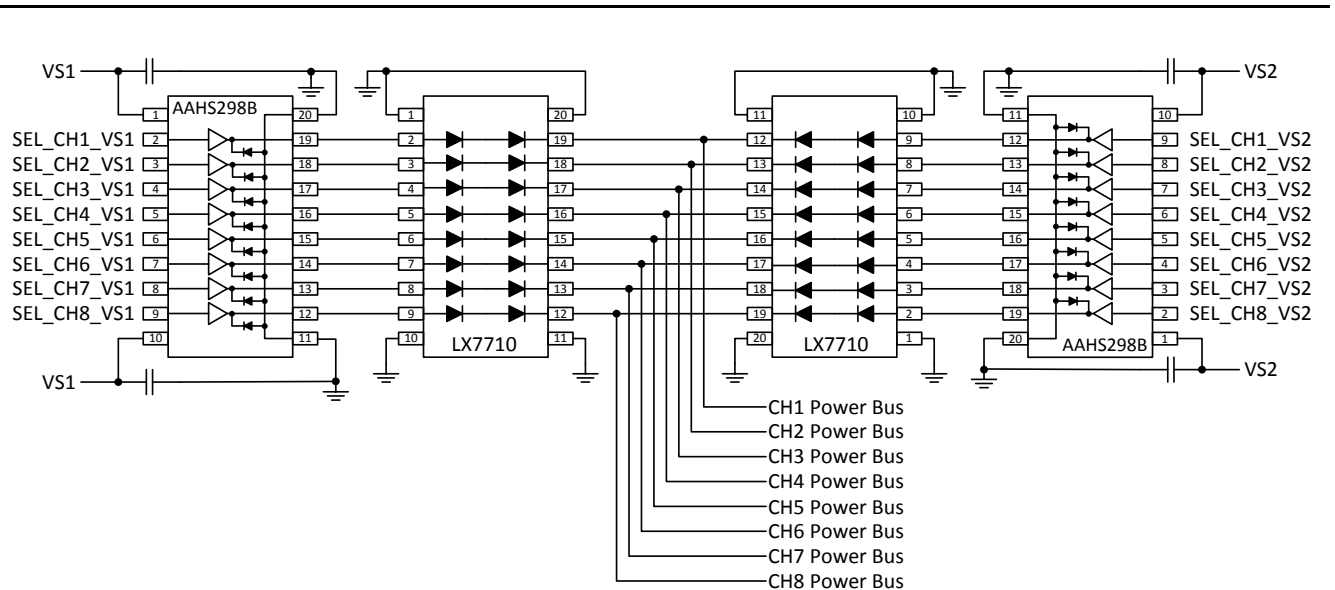

Figure 1 · Product Highlight of Redundant Switchable Power Bus

Pin Configuration and Pinout

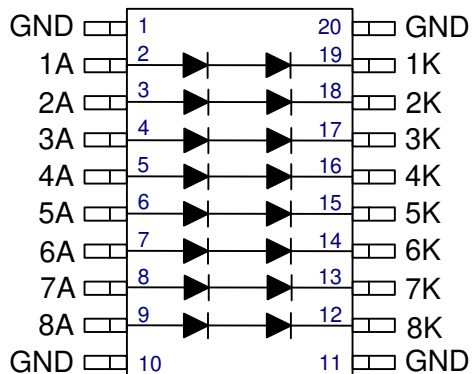

Figure 2 · LX7710 Pinout

Ordering Information

Junction Temperature	Type	Package	Part Number	Flow	Packaging Type
-55°C to 150°C	Flat Hermetic	CSOIC 20L	LX7710MDWC-ES	Engineering samples	Tray
			LX7710MDWC-Q SMD 5962-1621001QXC	QML-Q	
			LX7710MDWC-V SMD 5962-1621001VXC	QML-V	

Pin Description

Pin Number	Pin Designator	Description
1	GND	This power input pin connects to GND.
2	1A	This power input pin connects to the anode of the diode for channel 1.
3	2A	This power input pin connects to the anode of the diode for channel 2.
4	3A	This power input pin connects to the anode of the diode for channel 3.
5	4A	This power input pin connects to the anode of the diode for channel 4.
6	5A	This power input pin connects to the anode of the diode for channel 5.
7	6A	This power input pin connects to the anode of the diode for channel 6.
8	7A	This power input pin connects to the anode of the diode for channel 7.

Pin Number	Pin Designator	Description
9	8A	This power input pin connects to the anode of the diode for channel 8.
10	GND	This power input pin connects to GND.
11	GND	This power input pin connects to GND.
12	8K	This power input pin connects to the cathode of the diode for channel 8.
13	7K	This power input pin connects to the cathode of the diode for channel 7.
14	6K	This power input pin connects to the cathode of the diode for channel 6.
15	5K	This power input pin connects to the cathode of the diode for channel 5.
16	4K	This power input pin connects to the cathode of the diode for channel 4.
17	3K	This power input pin connects to the cathode of the diode for channel 3.
18	2K	This power input pin connects to the cathode of the diode for channel 2.
19	1K	This power input pin connects to the cathode of the diode for channel 1.
20	GND	This power input pin connects to GND.

Block Diagram

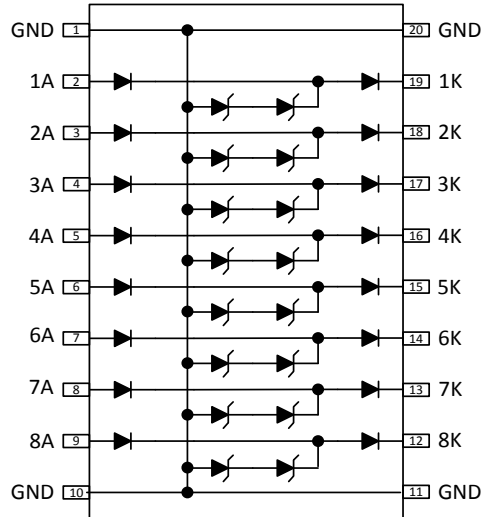

Figure 3 · Top Level Block Diagram of LX7710

Two Zener diodes in series provide redundant ESD protection. They are capable of up to 1A forward current and are suitable for suppressing inductive kickback.

Absolute Maximum Ratings

Note: Stresses above those listed in “ABSOLUTE MAXIMUM RATINGS”, may cause permanent damage to the device. This is a stress only rating and operation of the device at these or any other conditions above those indicated in the operational sections of this specification is not implied. Exceeding these ratings, even momentarily, can cause immediate damage, or negatively impact long-term operating reliability.

Parameter	Min	Max	Units
Reverse Voltage per Diode		140	V
Reverse Current (into K pin or out of GND pin)		100	μA
Continuous Forward Current		1	A
Storage Temperature Range	-65	150	°C
Operating Junction Temperature Range	-55	150	°C
Peak Lead Solder Temperature (10 seconds)		300	°C
Package Peak Temperature for Solder Reflow (40 seconds maximum exposure)		260 (+0, -5)	°C

Thermal Properties

Thermal Resistance	Typ	Units
Thermal Resistance-Junction to Case, θ_{JC}	3	$^{\circ}\text{C}/\text{W}$

Note: The θ_{JC} number is for conduction only to the ceramic base of the package. It assumes that the ceramic base has a thermal epoxy underneath the ceramic package to exhaust the heat from the package into the PCB, or other mounting surface.

Electrical Characteristics

Unless otherwise noted, these specifications apply $-55^{\circ}\text{C} \leq T_A \leq +125^{\circ}\text{C}$. Low duty cycle pulse testing is used which keeps junction and case temperatures equal to the ambient temperature.

Symbol	Parameter	Test Condition	Min	Typ	Max	Units
V_{BR_G-A}	Reverse Breakdown	$I_R = 10\mu\text{A}$; GND to anode	125			V
V_{BR_K-A}	Reverse Breakdown	$I_R = 10\mu\text{A}$; K to A Note:1	125			
V_{BR_A-G}	ESD Breakdown	$I_R = 10\mu\text{A}$; anode to GND Note:1	125			
V_{FWD_A-K}	Forward Voltage	$I_F = 100\text{mA}$	1.49	1.54	1.61	V
		$I_F = 350\text{mA}$	1.65	1.74	1.86	
		$I_F = 700\text{mA}$	1.80	1.92	2.08	
		$I_F = 700\text{mA}$ at 125°C	1.64	1.76	1.84	
		$I_F = 700\text{mA}$ at -55°C	1.91	2.07	2.24	
I_R	Reverse Current	$V_R = 75\text{V}$ at -55°C and 25°C ; GND to A			100	nA
		$V_R = 75\text{V}$ at 125°C ; GND to A			50	μA
C	Capacitance	$V_R = 0\text{V}$ at $f = 1\text{MHz}$; K to A	10	15	30	pF

Note: 1 These are go/no-go tests.

Typical Application

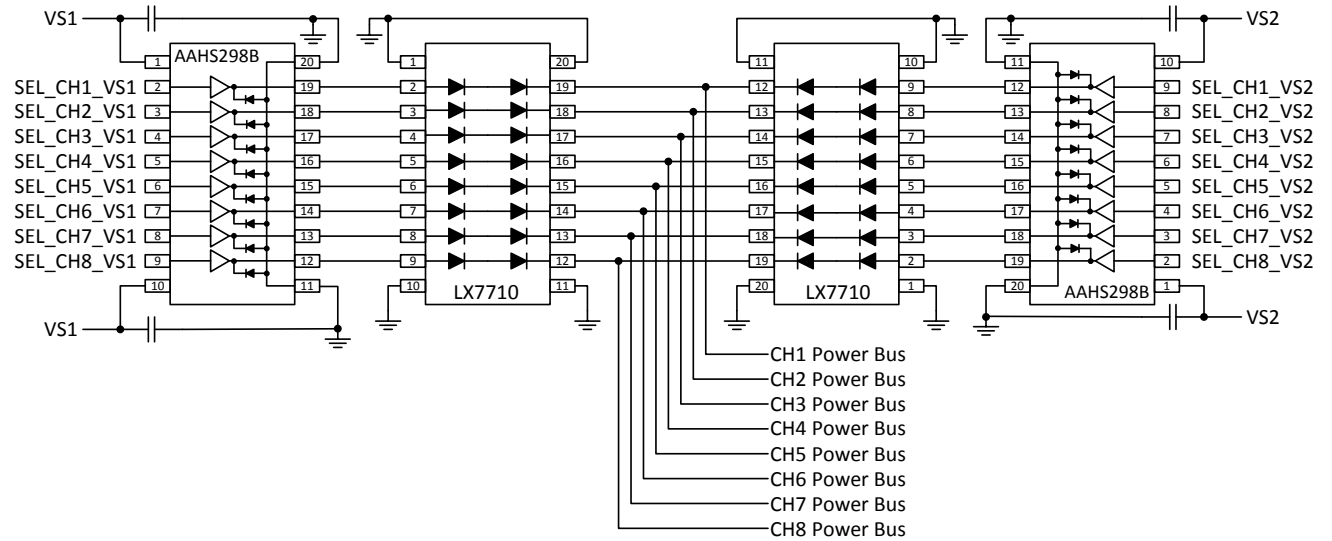

Figure 4 · LX7710 Typical Application

Note: For LX7710, it is necessary to Ground pins 1, 10, 11, and 20 for all applications.

Typical Performance Curves

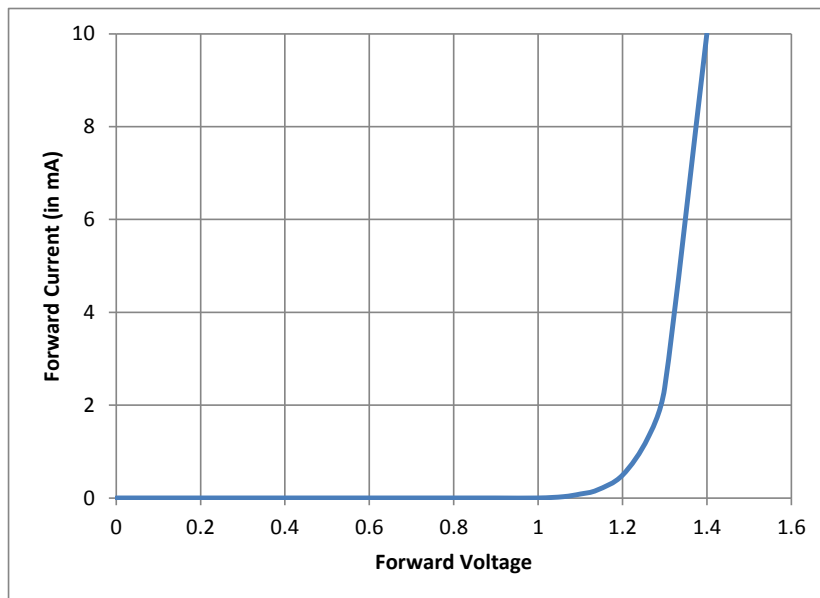

Figure 5 · Forward Characteristics : Measured A to K (two diodes in series)

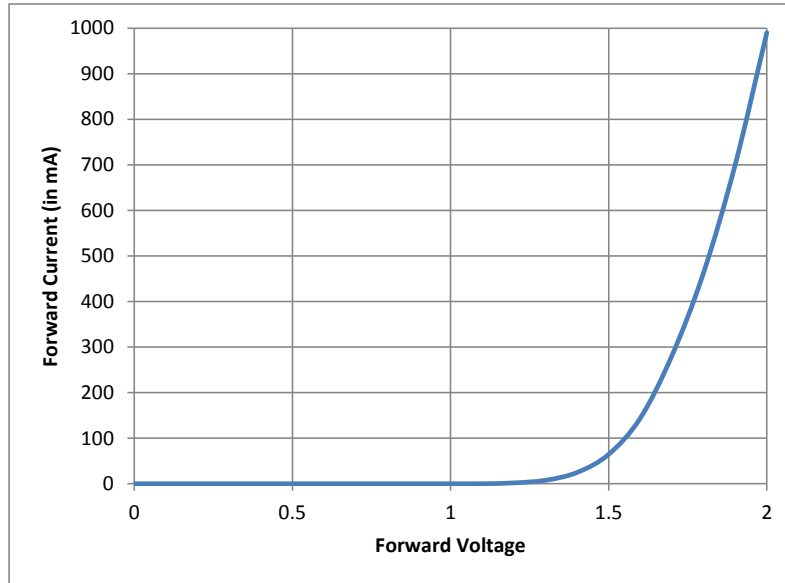
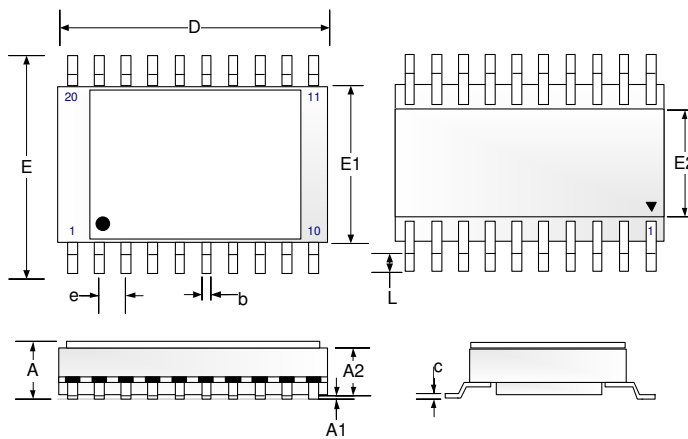

Figure 6 · Forward Characteristics : Measured A to K (two diodes in series)

Ceramic SOIC 20L Package Outline Dimensions



Dim	MILLIMETERS		INCHES	
	MIN	MAX	MIN	MAX
A	2.28	2.92	0.090	0.115
A1		0.38		0.015
A2	1.78	2.41	0.070	0.095
b	0.36	0.48	.0140	.0190
c	0.15	0.25	0.006	0.010
D	12.45	13.08	0.490	0.515
E	10.16	11.18	0.400	0.440
E1	7.24	7.62	0.285	0.300
E2	4.70 BSC		0.185 BSC	
e	1.27 BSC		0.050 BSC	
L	0.50	0.76	0.020	0.030

Note:

Dimensions are in mm, inches for reference only

Figure 7 · Package Dimensions



Microsemi Corporate Headquarters
One Enterprise, Aliso Viejo,
CA 92656 USA

Within the USA: +1 (800) 713-4113
Outside the USA: +1 (949) 380-6100
Sales: +1 (949) 380-6136
Fax: +1 (949) 215-4996

E-mail: sales.support@microsemi.com

© 2016 Microsemi Corporation. All rights reserved. Microsemi and the Microsemi logo are trademarks of Microsemi Corporation. All other trademarks and service marks are the property of their respective owners.

Microsemi Corporation (Nasdaq: MSCC) offers a comprehensive portfolio of semiconductor and system solutions for communications, defense & security, aerospace and industrial markets. Products include high-performance and radiation-hardened analog mixed-signal integrated circuits, FPGAs, SoCs and ASICs; power management products; timing and synchronization devices and precise time solutions, setting the world's standard for time; voice processing devices; RF solutions; discrete components; security technologies and scalable anti-tamper products; Power-over-Ethernet ICs and midspans; as well as custom design capabilities and services. Microsemi is headquartered in Aliso Viejo, Calif., and has approximately 3,400 employees globally. Learn more at www.microsemi.com.

Microsemi makes no warranty, representation, or guarantee regarding the information contained herein or the suitability of its products and services for any particular purpose, nor does Microsemi assume any liability whatsoever arising out of the application or use of any product or circuit. The products sold hereunder and any other products sold by Microsemi have been subject to limited testing and should not be used in conjunction with mission-critical equipment or applications. Any performance specifications are believed to be reliable but are not verified, and Buyer must conduct and complete all performance and other testing of the products, alone and together with, or installed in, any end-products. Buyer shall not rely on any data and performance specifications or parameters provided by Microsemi. It is the Buyer's responsibility to independently determine suitability of any products and to test and verify the same. The information provided by Microsemi hereunder is provided "as is, where is" and with all faults, and the entire risk associated with such information is entirely with the Buyer. Microsemi does not grant, explicitly or implicitly, to any party any patent rights, licenses, or any other IP rights, whether with regard to such information itself or anything described by such information. Information provided in this document is proprietary to Microsemi, and Microsemi reserves the right to make any changes to the information in this document or to any products and services at any time without notice.