

NOTES:

1. MATERIAL:
 - A) SHIELD: PHOSPHOR BRONZE PER QQ-B-750.
 - B) CAPTIVE SCREW: STAINLESS STEEL PER QQ-S-763, 300 SERIES.
 - C) CLAMP INSERT: FLUOROSILICONE ELASTOMER PER MIL-R-25988.
2. FINISH: A) SHIELD: ENTIRE SHIELD IS TIN PLATED PER MIL-T-10727, OVER NICKEL PER MIL-C-26074. B) CAPTIVE SCREW: CADMIUM PLATED PER QQ-P-416, OVER NICKEL UNDER PLATE.
3. RAYCHEM PART NUMBER CHA-0048 IS MARKED ON BACKSHELL PACKAGE.
4. WHEN SCREWS ARE TIGHTENED TO ACHIEVE 0.1 INCH SPACING BETWEEN SHELL HALVES (EAR THICKNESS) THIS DIMENSION SHALL BE 0.243 MIN.
5. THIS BACKSHELL IS FOR USE WITH RAYCHEM MTC SERIES CONNECTORS 1 INCH PLUG OR 1 INCH RECEPTACLE AS SHOWN. FURTHERMORE IT IS FOR USE ON CADMIUM PLATED CONNECTORS WHERE 500 HOURS SALT SPRAY RESISTANCE IS REQUIRED.

REVISIONS			
LTR	DESCRIPTION	DATE	APPROVED
A	REVISED PER ECN#T-6234	3-24-86	J.B.
B	REDRAWN PER DCR# T-29118	4-16-2001	M.HIGGY
C	REVISE PER DCR# T-29218	5/10/2001	M.HIGGY

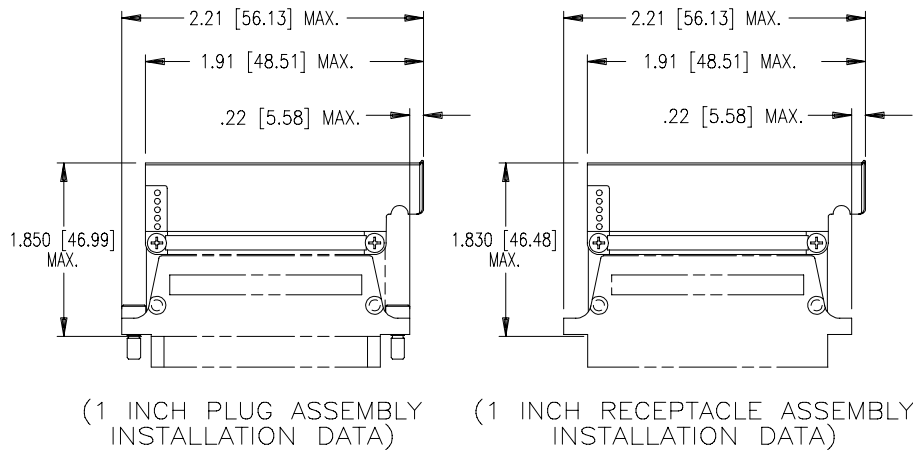
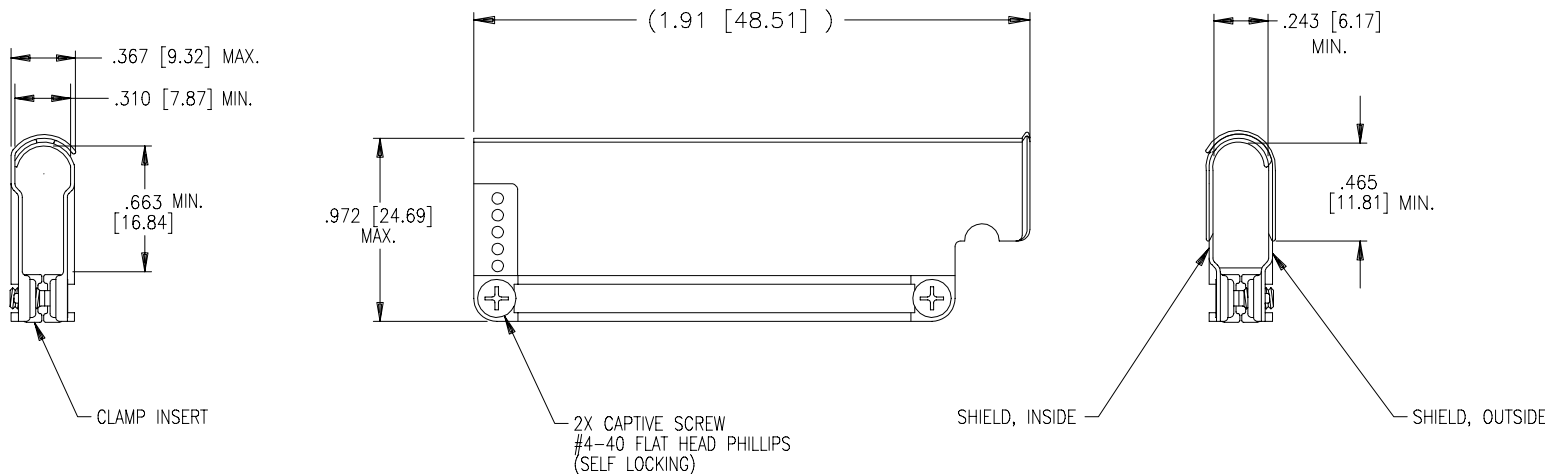

**If this document is printed it becomes uncontrolled.
Check with the web for latest revision.**

SPECIFICATION CONTROL DRAWING

UNLESS OTHERWISE SPECIFIED DIMENSIONS ARE IN INCHES. METRIC DIMENSIONS ARE IN BRACKETS. DECIMALS .XXX ± } mm .XX ± } mm ANGLES .X ± WEIGHT: [20 Grams] Maximum.	DRAWN	ZS.ORBAN 4-11-2001	tyco /Electronics/Raychem WIRE AND HARNESSING PRODUCTS 307 CONSTITUTION DRIVE MENLO PARK, CALIFORNIA 94025			
	CHECKED					
	APPROVED	M.HIGGY 4-16-2001	TITLE			
	APPROVED		RIGHT ANGLE BREAKOUT (1.9 LONG) BACKSHELL ASSY. (FOR CADMIUM PLATED CONNECTORS) 1 INCH MTC			
CAD NAME	T29218.DWG		SIZE	CODE IDENT. NO.	DWG. NO.	REV
THIRD ANGLE PROJECTION			C	06090	CHA-0048-003	C
DO NOT SCALE THIS DRAWING			SHEET 1 OF 1			