

FSBF15CH60BTL Smart Power Module

Features

- UL Certified No.E209204(SPM27-JB package)
- 600V-15A 3-phase IGBT inverter bridge including control ICs for gate driving and protection
- Easy PCB layout due to built in bootstrap diode
- Divided negative dc-link terminals for inverter current sensing applications
- Single-grounded power supply due to built-in HVIC
- Isolation rating of 2500Vrms/min.

Applications

- AC 100V ~ 253V three-phase inverter drive for small power ac motor drives
- Home appliances applications like air conditioner and washing machine

General Description

It is an advanced motion-smart power module (Motion-SPM™) that Fairchild has newly developed and designed to provide very compact and high performance ac motor drives mainly targeting low-power inverter-driven application like air conditioner and washing machine. It combines optimized circuit protection and drive matched to low-loss IGBTs. System reliability is further enhanced by the integrated under-voltage lock-out and short-circuit protection. The high speed built-in HVIC provides opto-coupler-less single-supply IGBT gate driving capability that further reduce the overall size of the inverter system design. Each phase current of inverter can be monitored separately due to the divided negative dc terminals.

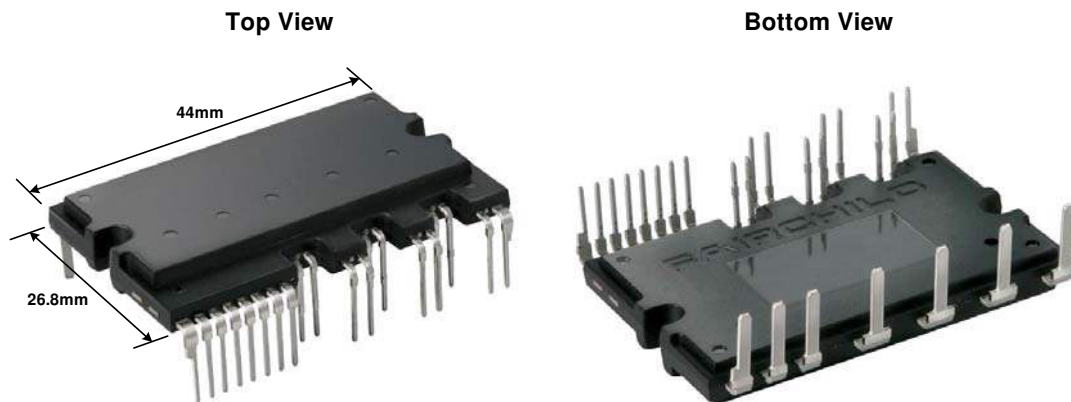

Figure 1.

Integrated Power Functions

- 600V-15A IGBT inverter for three-phase DC/AC power conversion (Please refer to Figure 3)

Integrated Drive, Protection and System Control Functions

- For inverter high-side IGBTs: Gate drive circuit, High voltage isolated high-speed level shifting
Control circuit under-voltage (UV) protection
Note) Available bootstrap circuit example is given in Figures 12 and 13.
- For inverter low-side IGBTs: Gate drive circuit, Short circuit protection (SC)
Control supply circuit under-voltage (UV) protection
- Fault signaling: Corresponding to UV (Low-side supply) and SC faults
- Input interface: 3.3/5V CMOS/LSTTL compatible, Schmitt trigger input

Pin Configuration

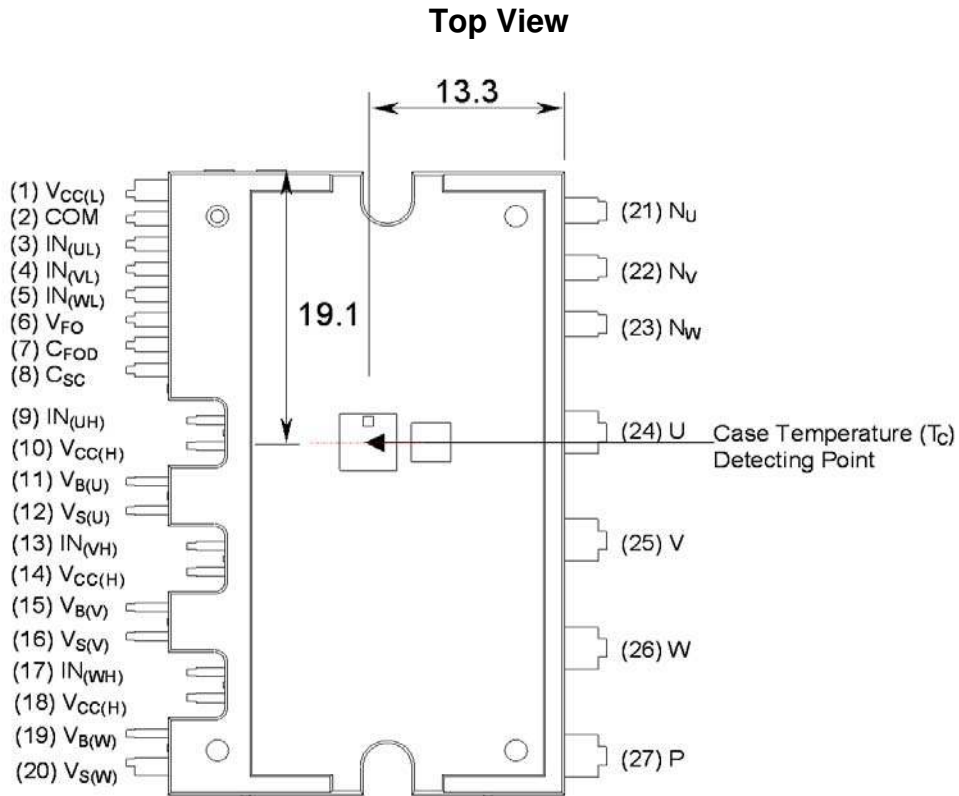

Pin Descriptions

Pin Number	Pin Name	Pin Description
1	$V_{CC(L)}$	Low-side Common Bias Voltage for IC and IGBTs Driving
2	COM	Common Supply Ground
3	$IN_{(UL)}$	Signal Input for Low-side U Phase
4	$IN_{(VL)}$	Signal Input for Low-side V Phase
5	$IN_{(WL)}$	Signal Input for Low-side W Phase
6	V_{FO}	Fault Output
7	C_{FOD}	Capacitor for Fault Output Duration Time Selection
8	C_{SC}	Capacitor (Low-pass Filter) for Short-Current Detection Input
9	$IN_{(UH)}$	Signal Input for High-side U Phase
10	$V_{CC(H)}$	High-side Common Bias Voltage for IC and IGBTs Driving
11	$V_{B(U)}$	High-side Bias Voltage for U Phase IGBT Driving
12	$V_{S(U)}$	High-side Bias Voltage Ground for U Phase IGBT Driving
13	$IN_{(VH)}$	Signal Input for High-side V Phase
14	$V_{CC(H)}$	High-side Common Bias Voltage for IC and IGBTs Driving
15	$V_{B(V)}$	High-side Bias Voltage for V Phase IGBT Driving
16	$V_{S(V)}$	High-side Bias Voltage Ground for V Phase IGBT Driving
17	$IN_{(WH)}$	Signal Input for High-side W Phase
18	$V_{CC(H)}$	High-side Common Bias Voltage for IC and IGBTs Driving
19	$V_{B(W)}$	High-side Bias Voltage for W Phase IGBT Driving
20	$V_{S(W)}$	High-side Bias Voltage Ground for W Phase IGBT Driving
21	N_U	Negative DC–Link Input for U Phase
22	N_V	Negative DC–Link Input for V Phase
23	N_W	Negative DC–Link Input for W Phase
24	U	Output for U Phase
25	V	Output for V Phase
26	W	Output for W Phase
27	P	Positive DC–Link Input

Internal Equivalent Circuit and Input/Output Pins

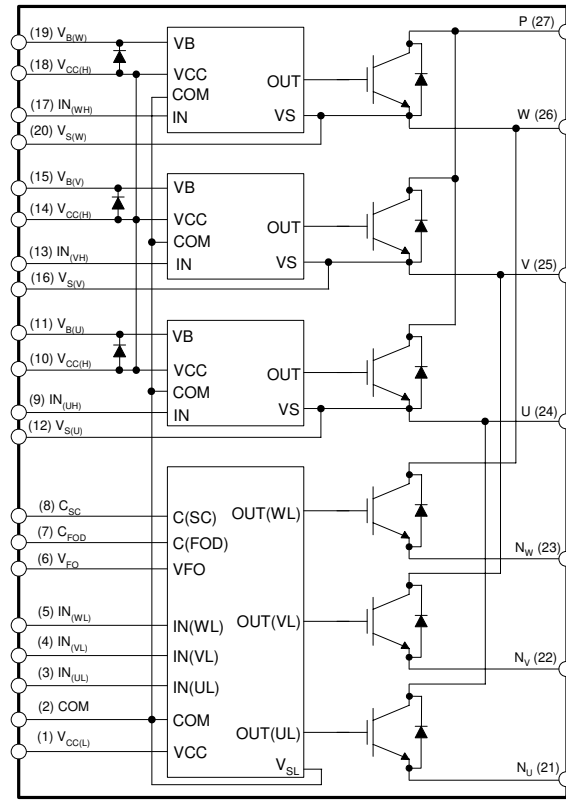

Note:

1. Inverter low-side is composed of three IGBTs, freewheeling diodes for each IGBT and one control IC. It has gate drive and protection functions.
2. Inverter power side is composed of four inverter dc-link input terminals and three inverter output terminals.
3. Inverter high-side is composed of three IGBTs, freewheeling diodes and three drive ICs for each IGBT.

Figure 3.

Absolute Maximum Ratings ($T_J = 25^\circ\text{C}$, Unless Otherwise Specified)

Inverter Part

Symbol	Parameter	Conditions	Rating	Units
V_{PN}	Supply Voltage	Applied between P- N_U , N_V , N_W	450	V
$V_{PN(\text{Surge})}$	Supply Voltage (Surge)	Applied between P- N_U , N_V , N_W	500	V
V_{CES}	Collector-emitter Voltage		600	V
$\pm I_C$	Each IGBT Collector Current	$T_C = 25^\circ\text{C}$	15	A
$\pm I_{CP}$	Each IGBT Collector Current (Peak)	$T_C = 25^\circ\text{C}$, Under 1ms Pulse Width	30	A
P_C	Collector Dissipation	$T_C = 25^\circ\text{C}$ per One Chip	25	W
T_J	Operating Junction Temperature	(Note 1)	-40 ~ 150	$^\circ\text{C}$

Note:

1. The maximum junction temperature rating of the power chips integrated within the SPM is $150^\circ\text{C} (@T_C \leq 125^\circ\text{C})$.

Control Part

Symbol	Parameter	Conditions	Rating	Units
V_{CC}	Control Supply Voltage	Applied between $V_{CC(H)}$, $V_{CC(L)}$ - COM	20	V
V_{BS}	High-side Control Bias Voltage	Applied between $V_{B(U)} - V_{S(U)}$, $V_{B(V)} - V_{S(V)}$, $V_{B(W)} - V_{S(W)}$	20	V
V_{IN}	Input Signal Voltage	Applied between $IN_{(UH)}$, $IN_{(VH)}$, $IN_{(WH)}$, $IN_{(UL)}$, $IN_{(VL)}$, $IN_{(WL)}$ - COM	-0.3~17	V
V_{FO}	Fault Output Supply Voltage	Applied between V_{FO} - COM	$-0.3 \sim V_{CC} + 0.3$	V
I_{FO}	Fault Output Current	Sink Current at V_{FO} Pin	5	mA
V_{SC}	Current Sensing Input Voltage	Applied between C_{SC} - COM	$-0.3 \sim V_{CC} + 0.3$	V

Bootstrap Diode Part

Symbol	Parameter	Conditions	Rating	Units
V_{RRM}	Maximum Repetitive Reverse Voltage		600	V
I_F	Forward Current	$T_C = 25^\circ\text{C}$	0.5	A
I_{FP}	Forward Current (Peak)	$T_C = 25^\circ\text{C}$, Under 1ms Pulse Width	2	A
T_J	Operating Junction Temperature		-40 ~ 150	$^\circ\text{C}$

Total System

Symbol	Parameter	Conditions	Rating	Units
$V_{PN(\text{PROT})}$	Self Protection Supply Voltage Limit (Short Circuit Protection Capability)	$V_{CC} = V_{BS} = 13.5 \sim 16.5\text{V}$ $T_J = 150^\circ\text{C}$, Non-repetitive, less than $2\mu\text{s}$	400	V
T_C	Module Case Operation Temperature	$-40^\circ\text{C} \leq T_J \leq 150^\circ\text{C}$, See Figure 2	-40 ~ 125	$^\circ\text{C}$
T_{STG}	Storage Temperature		-40 ~ 150	$^\circ\text{C}$
V_{ISO}	Isolation Voltage	60Hz, Sinusoidal, AC 1 minute, Connection Pins to heat sink plate	2500	V_{rms}

Thermal Resistance

Symbol	Parameter	Conditions	Min.	Typ.	Max.	Units
$R_{th(j-c)Q}$	Junction to Case Thermal Resistance	Inverter IGBT part (per 1/6 module)	-	-	4.9	$^\circ\text{C/W}$
$R_{th(j-c)F}$		Inverter FWD part (per 1/6 module)	-	-	5.7	$^\circ\text{C/W}$

Note:

2. For the measurement point of case temperature(T_C), please refer to Figure 2.

Electrical Characteristics (T_J = 25°C, Unless Otherwise Specified)

Inverter Part

Symbol	Parameter	Conditions		Min.	Typ.	Max.	Units
V _{CE(SAT)}	Collector-Emitter Saturation Voltage	V _{CC} = V _{BS} = 15V V _{IN} = 5V	I _C = 15A, T _J = 25°C	-	-	2.2	V
V _F	FWD Forward Voltage	V _{IN} = 0V	I _F = 15A, T _J = 25°C	-	-	2.5	V
HS	t _{ON}	V _{PN} = 300V, V _{CC} = V _{BS} = 15V I _C = 15A V _{IN} = 0V ↔ 5V, Inductive Load (Note 3)		-	0.75	-	μs
	t _{C(ON)}			-	0.20	-	μs
	t _{OFF}			-	0.55	-	μs
	t _{C(OFF)}			-	0.10	-	μs
	t _{rr}			-	0.10	-	μs
LS	t _{ON}	V _{PN} = 300V, V _{CC} = V _{BS} = 15V I _C = 15A V _{IN} = 0V ↔ 5V, Inductive Load (Note 3)		-	0.45	-	μs
	t _{C(ON)}			-	0.25	-	μs
	t _{OFF}			-	0.55	-	μs
	t _{C(OFF)}			-	0.10	-	μs
	t _{rr}			-	0.10	-	μs
I _{CES}	Collector-Emitter Leakage Current	V _{CE} = V _{CES}		-	-	1	mA

Note:

3. t_{ON} and t_{OFF} include the propagation delay time of the internal drive IC. t_{C(ON)} and t_{C(OFF)} are the switching time of IGBT itself under the given gate driving condition internally. For the detailed information, please see Figure 4.

Control Part

Symbol	Parameter	Conditions		Min.	Typ.	Max.	Units
I _{QCCL}	Quiescent V _{CC} Supply Current	V _{CC} = 15V I _{N(UL, VL, WL)} = 0V	V _{CC(L)} - COM	-	-	23	mA
I _{QCCH}		V _{CC} = 15V I _{N(UH, VH, WH)} = 0V	V _{CC(H)} - COM	-	-	600	μA
I _{QBS}	Quiescent V _{BS} Supply Current	V _{BS} = 15V I _{N(UH, VH, WH)} = 0V	V _{B(U)} - V _{S(U)} , V _{B(V)} - V _{S(V)} , V _{B(W)} - V _{S(W)}	-	-	500	μA
V _{FOH}	Fault Output Voltage	V _{SC} = 0V, V _{FO} Circuit: 4.7kΩ to 5V Pull-up		4.5	-	-	V
V _{FOL}		V _{SC} = 1V, V _{FO} Circuit: 4.7kΩ to 5V Pull-up		-	-	0.8	V
V _{SC(ref)}	Short Circuit Trip Level	V _{CC} = 15V (Note 4)		0.45	0.5	0.55	V
TSD	Over-temperature protection	Temperature at LVIC		-	160	-	°C
ΔTSD	Over-temperature protection hysteresis	Temperature at LVIC		-	5	-	°C
UV _{CCD}	Supply Circuit Under-Voltage Protection	Detection Level		10.7	11.9	13.0	V
UV _{CCR}		Reset Level		11.2	12.4	13.4	V
UV _{BSD}		Detection Level		10	11	12	V
UV _{BSR}		Reset Level		10.5	11.5	12.5	V
t _{FOD}	Fault-out Pulse Width	C _{FOD} = 33nF (Note 5)		1.0	1.8	-	ms
V _{IN(ON)}	ON Threshold Voltage	Applied between I _{N(UH)} , I _{N(VH)} , I _{N(WH)} , I _{N(UL)} ,		2.8	-	-	V
V _{IN(OFF)}	OFF Threshold Voltage	I _{N(VL)} , I _{N(WL)} - COM		-	-	0.8	V

Note:

4. Short-circuit current protection is functioning only at the low-sides.
 5. The fault-out pulse width t_{FOD} depends on the capacitance value of C_{FOD} according to the following approximate equation : C_{FOD} = 18.3 × 10⁻⁶ × t_{FOD}[F]

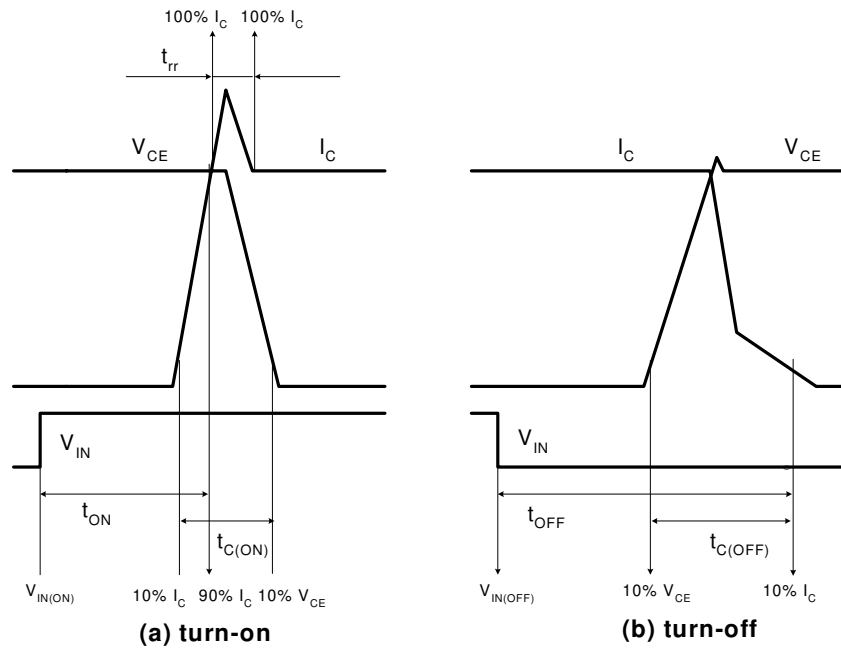

Figure 4. Switching Time Definition

Switching Loss (Typical)

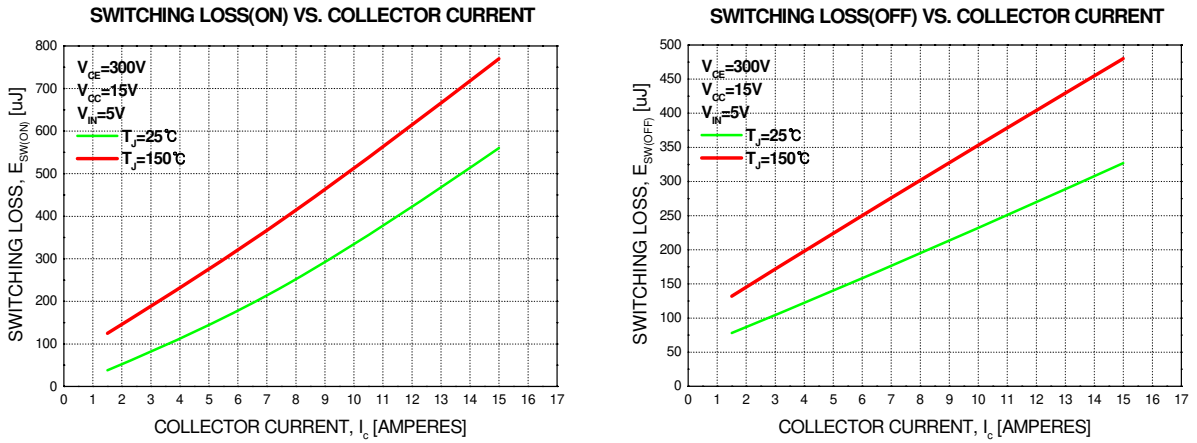
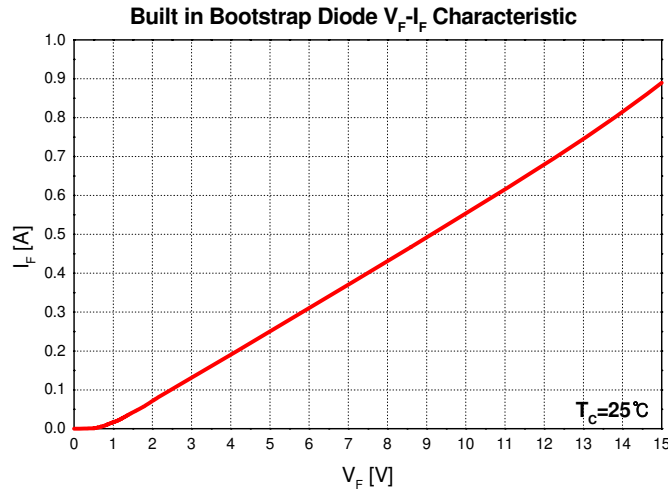

Figure 5. Switching Loss Characteristics

Bootstrap Diode Part

Symbol	Parameter	Conditions	Min.	Typ.	Max.	Units
V_F	Forward Voltage	$I_F = 0.1A, T_C = 25^\circ C$	-	2.5	-	V
t_{rr}	Reverse Recovery Time	$I_F = 0.1A, T_C = 25^\circ C$	-	80	-	ns



Note:

6. Built in bootstrap diode includes around 15Ω resistance characteristic.

Figure 6. Built in Bootstrap Diode Characteristics

Recommended Operating Conditions

Symbol	Parameter	Conditions	Value			Units
			Min.	Typ.	Max.	
V_{PN}	Supply Voltage	Applied between P - N_U, N_V, N_W	-	300	400	V
V_{CC}	Control Supply Voltage	Applied between $V_{CC(H)}, V_{CC(L)}$ - COM	13.5	15	16.5	V
V_{BS}	High-side Bias Voltage	Applied between $V_{B(U)} - V_{S(U)}, V_{B(V)} - V_{S(V)}, V_{B(W)} - V_{S(W)}$	13.0	15	18.5	V
$dV_{CC}/dt, dV_{BS}/dt$	Control supply variation		-1	-	1	V/ μs
t_{dead}	Blanking Time for Preventing Arm-short	For Each Input Signal	1.5	-	-	μs
f_{PWM}	PWM Input Signal	$-40^\circ C \leq T_C \leq 125^\circ C, -40^\circ C \leq T_J \leq 150^\circ C$	-	-	20	kHz
V_{SEN}	Voltage for Current Sensing	Applied between N_U, N_V, N_W - COM (Including surge voltage)	-4		4	V

Mechanical Characteristics and Ratings

Parameter	Conditions		Limits			Units
			Min.	Typ.	Max.	
Mounting Torque	Mounting Screw: - M3	Recommended 0.62N•m	0.51	0.62	1.00	N•m
Device Flatness		Note Figure 7	0	-	+120	μm
Weight			-	15.4	-	g

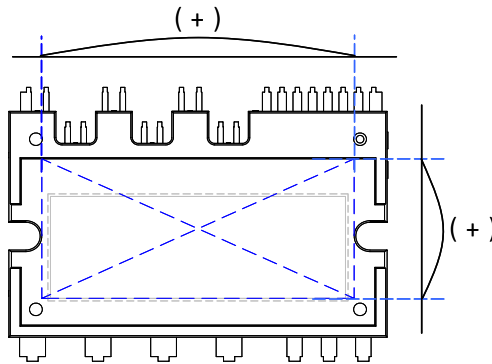
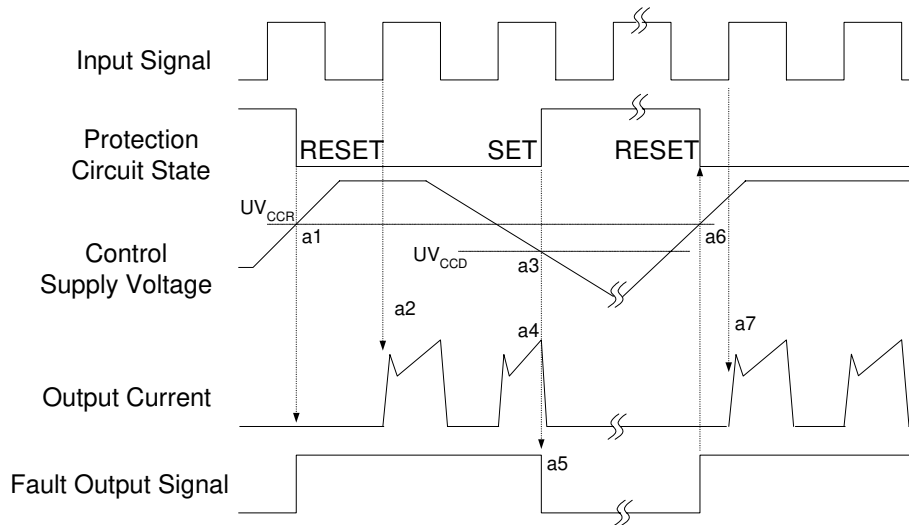

Figure 7. Flatness Measurement Position

Package Marking and Ordering Information

Device Marking	Device	Package	Reel Size	Tape Width	Quantity
FSBF15CH60BTL	FSBF15CH60BTL	SPM27-JB	-	-	10

Time Charts of SPMs Protective Function



- a1 : Control supply voltage rises: After the voltage rises UV_{CCR} , the circuits start to operate when next input is applied.
- a2 : Normal operation: IGBT ON and carrying current.
- a3 : Under voltage detection (UV_{CCD}).
- a4 : IGBT OFF in spite of control input condition.
- a5 : Fault output operation starts.
- a6 : Under voltage reset (UV_{CCR}).
- a7 : Normal operation: IGBT ON and carrying current.

Figure 8. Under-Voltage Protection (Low-side)

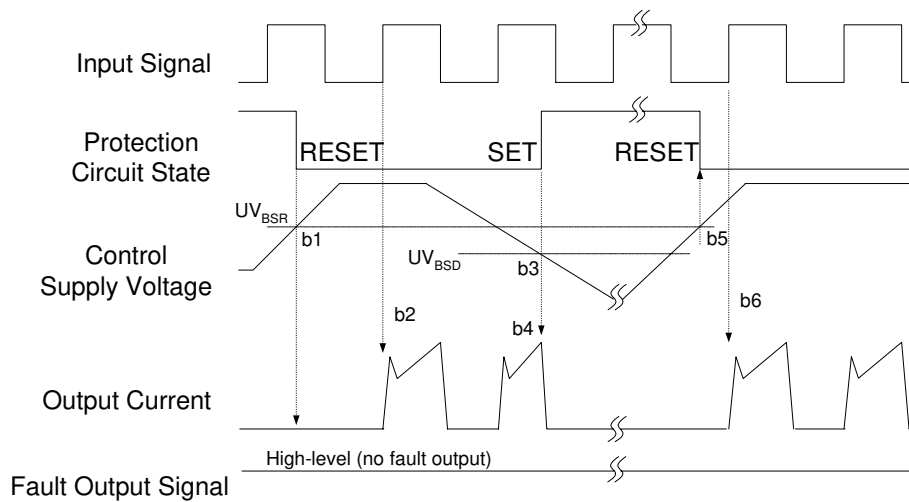

- b1 : Control supply voltage rises: After the voltage reaches UV_{BSR} , the circuits start to operate when next input is applied.
- b2 : Normal operation: IGBT ON and carrying current.
- b3 : Under voltage detection (UV_{BSD}).
- b4 : IGBT OFF in spite of control input condition, but there is no fault output signal.
- b5 : Under voltage reset (UV_{BSR})
- b6 : Normal operation: IGBT ON and carrying current

Figure 9. Under-Voltage Protection (High-side)

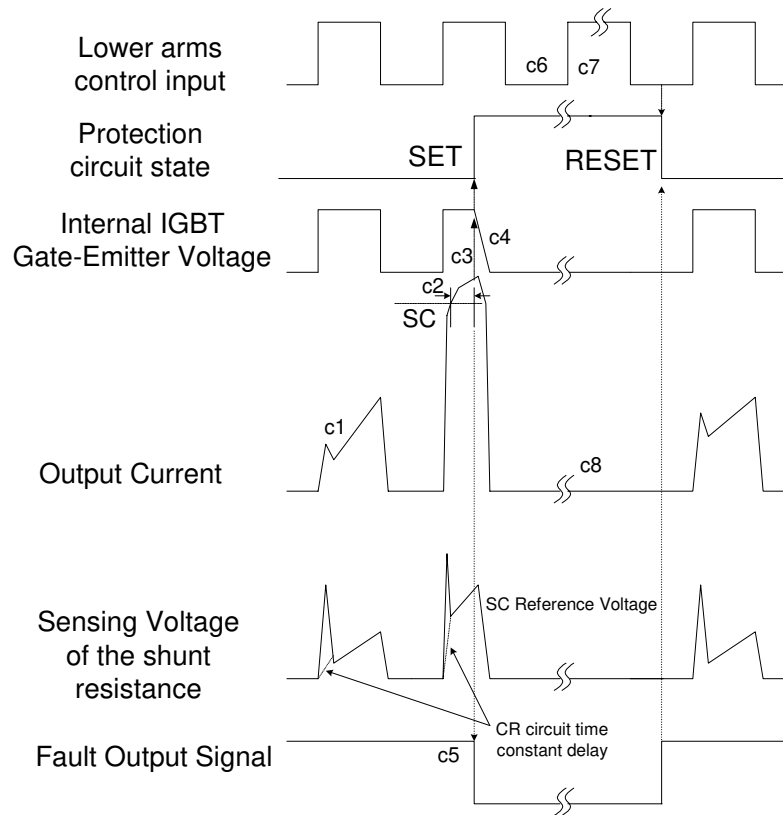

(with the external shunt resistance and CR connection)

c1 : Normal operation: IGBT ON and carrying current.

c2 : Short circuit current detection (SC trigger).

c3 : Hard IGBT gate interrupt.

c4 : IGBT turns OFF.

c5 : Fault output timer operation starts: The pulse width of the fault output signal is set by the external capacitor C_{FO} .

c6 : Input "L" : IGBT OFF state.

c7 : Input "H" : IGBT ON state, but during the active period of fault output the IGBT doesn't turn ON.

c8 : IGBT OFF state

Figure 10. Short-Circuit Current Protection (Low-side Operation only)

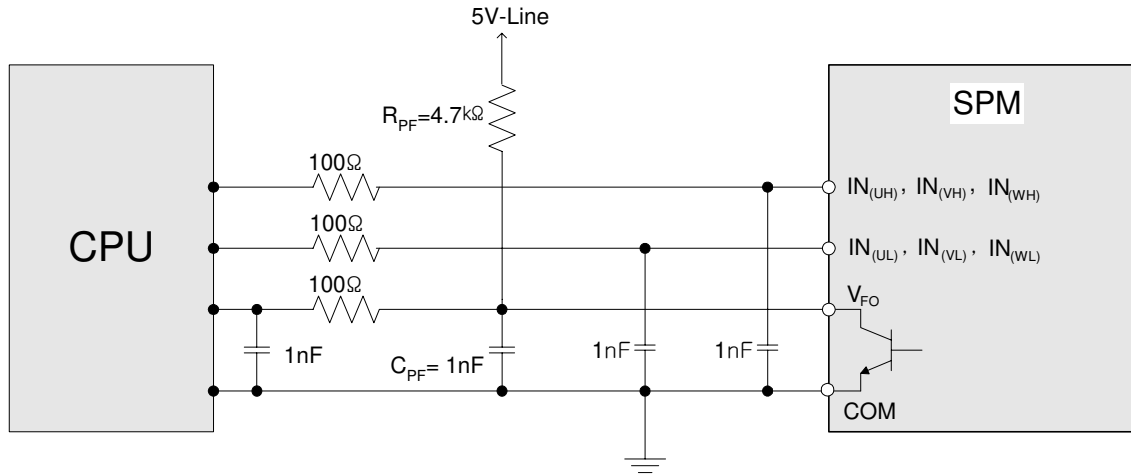

Note:

- 1) RC coupling at each input might change depending on the PWM control scheme used in the application and the wiring impedance of the application's printed circuit board. The SPM input signal section integrates 5kΩ (typ.) pull-down resistor. Therefore, when using an external filtering resistor, please pay attention to the signal voltage drop at input terminal.
- 2) The logic input is compatible with standard CMOS or LSTTL outputs.

Figure 11. Recommended CPU I/O Interface Circuit

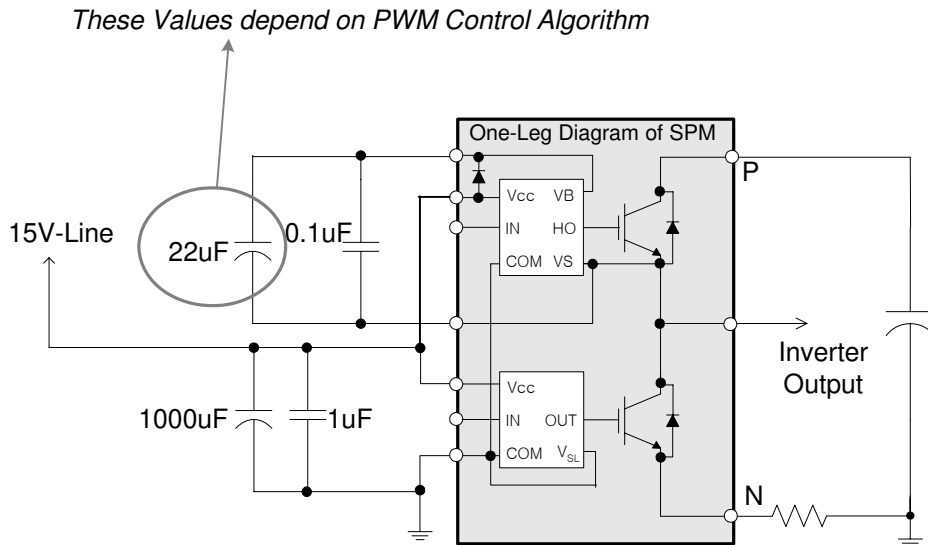

Note:

- 1) The ceramic capacitor placed between V_{CC}-COM should be over 1μF and mounted as close to the pins of the SPM as possible.

Figure 12. Recommended Bootstrap Operation Circuit and Parameters

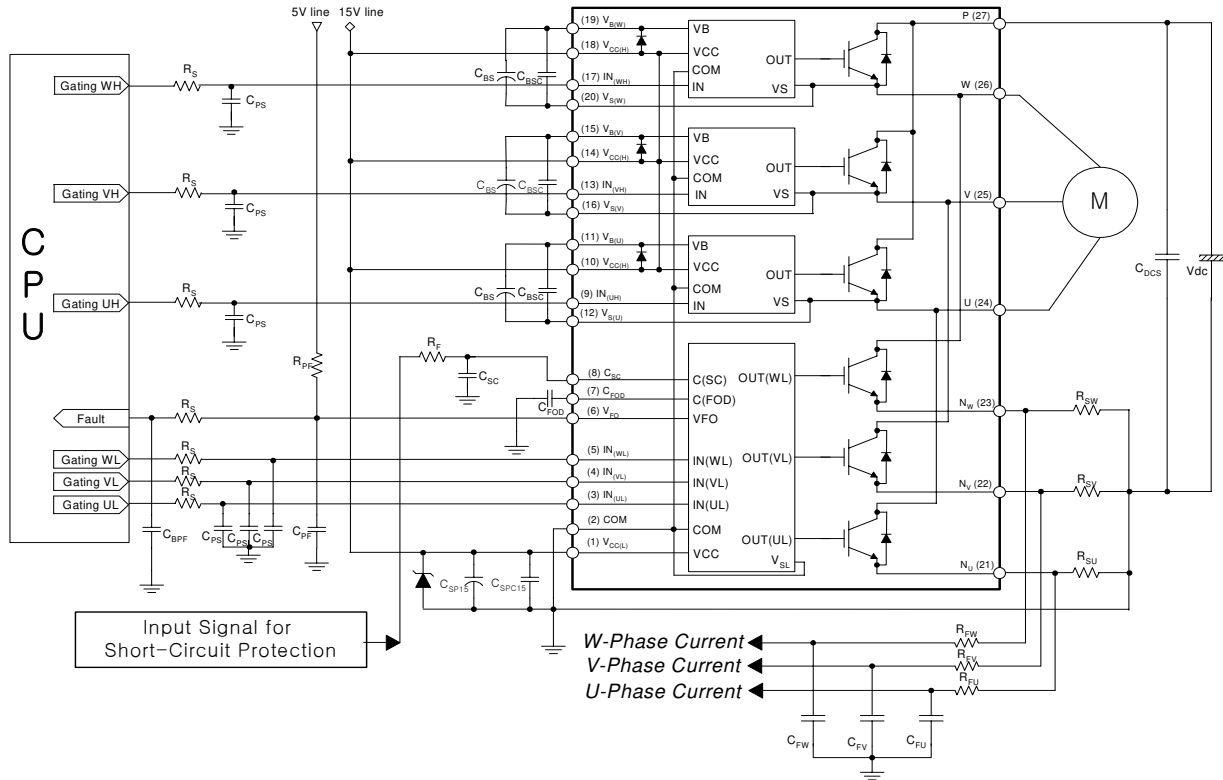

Note:

- 1) To avoid malfunction, the wiring of each input should be as short as possible. (less than 2-3cm)
- 2) By virtue of integrating an application specific type HVIC inside the SPM, direct coupling to CPU terminals without any opto-coupler or transformer isolation is possible.
- 3) VFO output is open collector type. This signal line should be pulled up to the positive side of the 5V power supply with approximately 4.7kΩ resistance. Please refer to Figure11.
- 4) C_{SP15} of around 7 times larger than bootstrap capacitor C_{BS} is recommended.
- 5) VFO output pulse width should be determined by connecting an external capacitor(C_{FOD}) between C_{FOD}(pin7) and COM(pin2). (Example : if C_{FOD} = 33 nF, then t_{FO} = 1.8ms (typ.)) Please refer to the note 5 for calculation method.
- 6) Input signal is High-Active type. There is a 5kΩ resistor inside the IC to pull down each input signal line to GND. RC coupling circuits should be adopted for the prevention of input signal oscillation. R_SC_{PS} time constant should be selected in the range 50~150ns. C_{PS} should not be less than 1nF. (Recommended R_S=100Ω , C_{PS}=1nF)
- 7) To prevent errors of the protection function, the wiring around R_F and C_{SC} should be as short as possible.
- 8) In the short-circuit protection circuit, please select the R_FC_{SC} time constant in the range 1.5~2μs.
- 9) Each capacitor should be mounted as close to the pins of the SPM as possible.
- 10) To prevent surge destruction, the wiring between the smoothing capacitor and the P&GND pins should be as short as possible. The use of a high frequency non-inductive capacitor of around 0.1~0.22μF between the P&GND pins is recommended.
- 11) Relays are used at almost every systems of electrical equipments of home appliances. In these cases, there should be sufficient distance between the CPU and the relays.
- 12) C_{SP15} should be over 1μF and mounted as close to the pins of the SPM as possible.

Figure 13. Typical Application Circuit

Detailed Package Outline Drawings

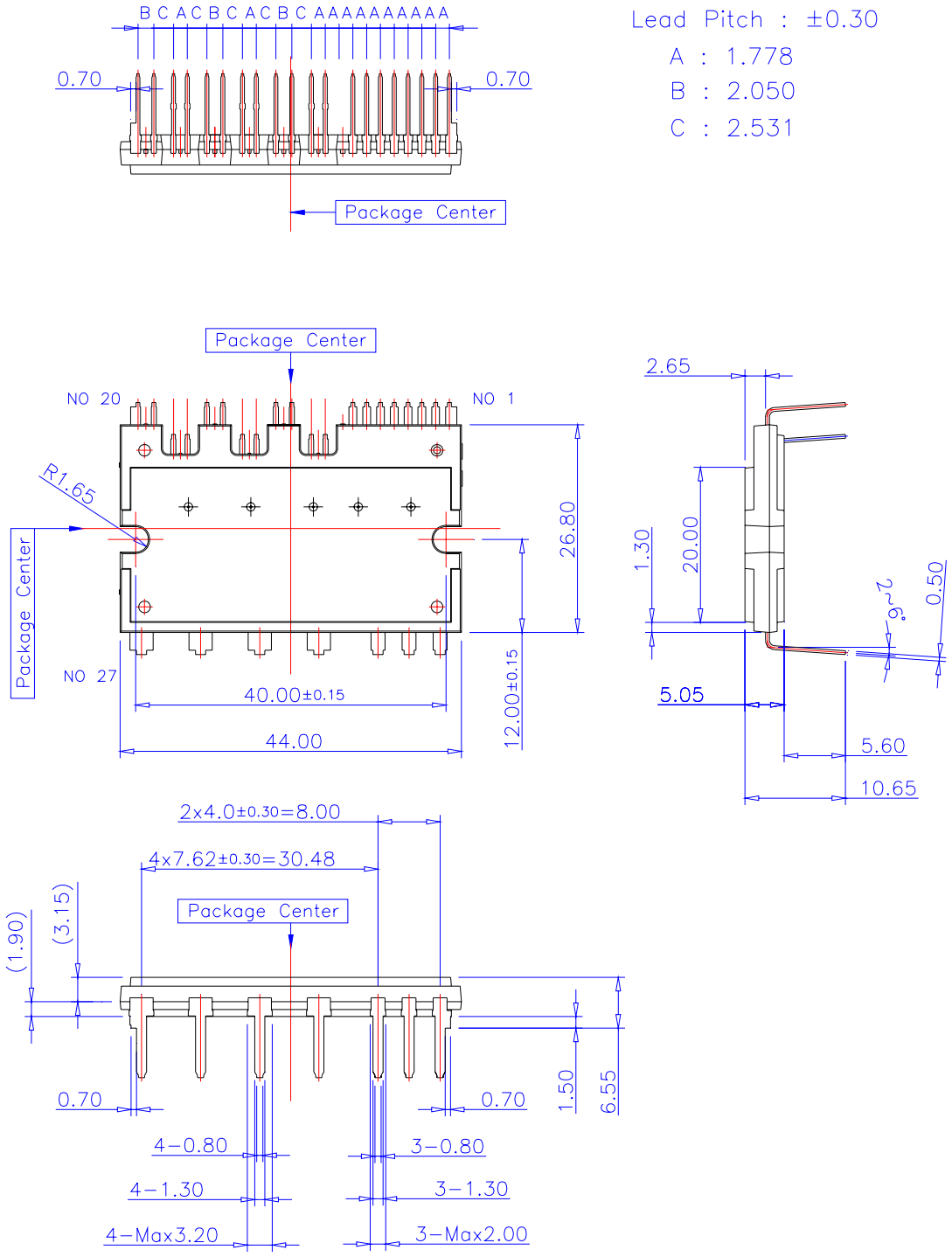

Detailed Package Outline Drawings (Continued)

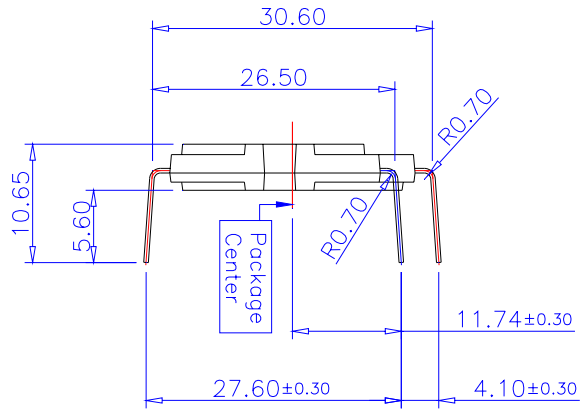

Lead Forming Dimension

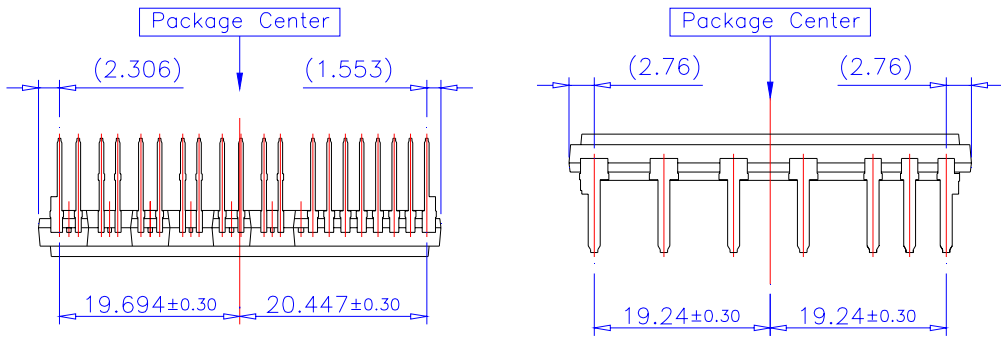

PKG Center to Lead Distance

Detailed Package Outline Drawings (Continued)

DETAIL LEAD

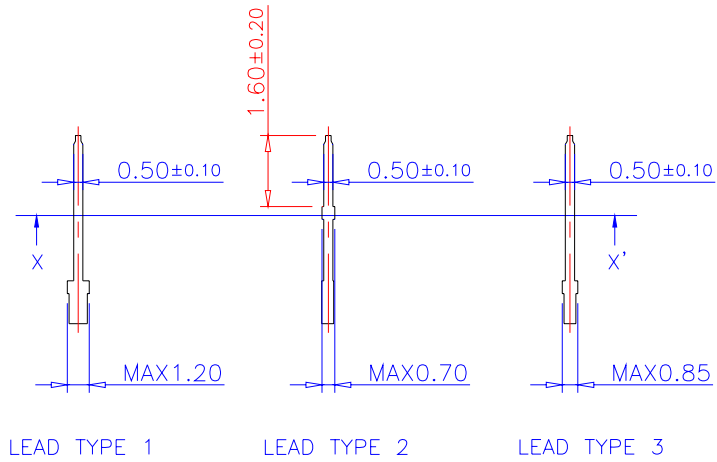
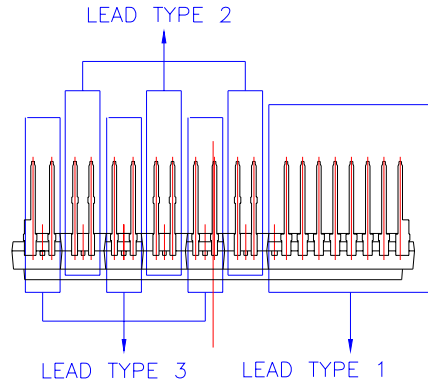

SCALE 2 : 1

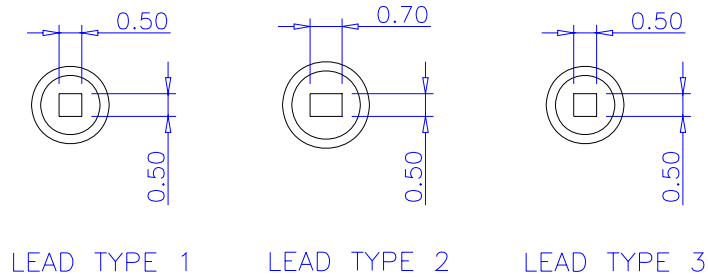





SCALE 5 : 1

LEAD SECTION X-X'



TRADEMARKS

The following includes registered and unregistered trademarks and service marks, owned by Fairchild Semiconductor and/or its global subsidiaries, and is not intended to be an exhaustive list of all such trademarks.

- | | | | |
|---|-------------------------|---|---|
| Build it Now™ | FPS™ | PDP SPM™ | The Power Franchise® |
| CorePLUS™ | F-PFS™ | Power-SPM™ | the power franchise |
| CorePOWER™ | FRFET® | PowerTrench® | TinyBoost™ |
| CROSSVOLT™ | Global Power ResourceSM | Programmable Active Droop™ | TinyBuck™ |
| CTL™ | Green FPS™ | QFET® | TinyLogic® |
| Current Transfer Logic™ | Green FPS™ e-Series™ | QS™ | TINYOPTO™ |
| EcoSPARK® | GTO™ | Quiet Series™ | TinyPower™ |
| EfficientMax™ | IntelliMAX™ | RapidConfigure™ | TinyPWM™ |
| EZSWITCH™ * | ISOPLANAR™ | Saving our world, 1mW at a time™ | TinyWire™ |
|  | MegaBuck™ | SmartMax™ |  |
|  | MICROCOUPLER™ | SMART START™ | UHC® |
| Fairchild® | MicroFET™ | SPM® | Ultra FRFET™ |
| Fairchild Semiconductor® | MicroPak™ | STEALTH™ | UniFET™ |
| FACT Quiet Series™ | MillerDrive™ | SuperFET™ | VCX™ |
| FACT® | MotionMax™ | SuperSOT™-3 | VisualMax™ |
| FAST® | Motion-SPM™ | SuperSOT™-6 | |
| FastvCore™ | OPTOLOGIC® | SuperSOT™-8 | |
| FlashWriter® * | OPTOPLANAR® | SuperMOS™ | |
| | | SyncFET™ | |
| | |  | |

* EZSWITCH™ and FlashWriter® are trademarks of System General Corporation, used under license by Fairchild Semiconductor.

DISCLAIMER

FAIRCHILD SEMICONDUCTOR RESERVES THE RIGHT TO MAKE CHANGES WITHOUT FURTHER NOTICE TO ANY PRODUCTS HEREIN TO IMPROVE RELIABILITY, FUNCTION, OR DESIGN. FAIRCHILD DOES NOT ASSUME ANY LIABILITY ARISING OUT OF THE APPLICATION OR USE OF ANY PRODUCT OR CIRCUIT DESCRIBED HEREIN; NEITHER DOES IT CONVEY ANY LICENSE UNDER ITS PATENT RIGHTS, NOR THE RIGHTS OF OTHERS. THESE SPECIFICATIONS DO NOT EXPAND THE TERMS OF FAIRCHILD'S WORLDWIDE TERMS AND CONDITIONS, SPECIFICALLY THE WARRANTY THEREIN, WHICH COVERS THESE PRODUCTS.

LIFE SUPPORT POLICY

FAIRCHILD'S PRODUCTS ARE NOT AUTHORIZED FOR USE AS CRITICAL COMPONENTS IN LIFE SUPPORT DEVICES OR SYSTEMS WITHOUT THE EXPRESS WRITTEN APPROVAL OF FAIRCHILD SEMICONDUCTOR CORPORATION.

As used herein:

1. Life support devices or systems are devices or systems which, (a) are intended for surgical implant into the body or (b) support or sustain life, and (c) whose failure to perform when properly used in accordance with instructions for use provided in the labeling, can be reasonably expected to result in a significant injury of the user.
2. A critical component in any component of a life support, device, or system whose failure to perform can be reasonably expected to cause the failure of the life support device or system, or to affect its safety or effectiveness.

ANTI-COUNTERFEITING POLICY

Fairchild Semiconductor Corporation's Anti-Counterfeiting Policy. Fairchild's Anti-Counterfeiting Policy is also stated on our external website, www.fairchildsemi.com, under Sales Support.

Counterfeiting of semiconductor parts is a growing problem in the industry. All manufactures of semiconductor products are experiencing counterfeiting of their parts. Customers who inadvertently purchase counterfeit parts experience many problems such as loss of brand reputation, substandard performance, failed application, and increased cost of production and manufacturing delays. Fairchild is taking strong measures to protect ourselves and our customers from the proliferation of counterfeit parts. Fairchild strongly encourages customers to purchase Fairchild parts either directly from Fairchild or from Authorized Fairchild Distributors who are listed by country on our web page cited above. Products customers buy either from fairchild directly or from Authorized Fairchild Distributors are genuine parts, have full traceability, meet Fairchild's quality standards for handling and storage and provide access to Fairchild's full range of up-to-date technical and product information. Fairchild and our Authorized Distributors will stand behind all warranties and will appropriately address and warranty issues that may arise. Fairchild will not provide any warranty coverage or other assistance for parts bought from Unauthorized Sources. Fairchild is committed to combat this global problem and encourage our customers to do their part in stopping this practice by buying direct or from authorized distributors.

PRODUCT STATUS DEFINITIONS

Definition of Terms

Datasheet Identification	Product Status	Definition
Advance Information	Formative / In Design	Datasheet contains the design specifications for product development. Specifications may change in any manner without notice.
Preliminary	First Production	Datasheet contains preliminary data; supplementary data will be published at a later date. Fairchild Semiconductor reserves the right to make changes at any time without notice to improve design.
No Identification Needed	Full Production	Datasheet contains final specifications. Fairchild Semiconductor reserves the right to make changes at any time without notice to improve the design.
Obsolete	Not In Production	Datasheet contains specifications on a product that is discontinued by Fairchild Semiconductor. The datasheet is for reference information only.