

OV9756 720p HD product brief



OmniVision's OV9756 with Second-Generation RGB-Ir Color Array Pattern Brings HD Imaging to Security and Smart Home Applications

OmniVision's OV9756 is a high sensitivity CameraChip™ sensor built on a second-generation RGB-Ir color array pattern for security and smart home applications. With a 1/3-inch optical format, the OV9756 delivers full resolution 720p high definition (HD) images and video at 60 frames per second (fps).

The OV9756's advanced color array pattern supports dual band color filters instead of traditional mechanical rotary IR filters, capturing infrared images and video with minimal color aliasing.

Built on a 3.75-micron OmniPixel3-HS™ pixel, the OV9756 can operate in extremely high- and low-light conditions, bringing excellent scene reproduction to a wide range of security and lifestyle camera applications. The OV9756 also features low power mode with system wake-up trigger functionality.

Find out more at www.ovt.com.



Applications

- Security and Surveillance Cameras
- PC Multimedia
- Wearables
- 960H for Analog CCTV Applications

Product Features

- 3.75 μm x 3.75 μm pixel
- 1280x960 at 60 fps @ 10-bit, 45 fps @ 12-bit
- programmable controls for:
 - frame rate
 - mirror and flip
 - cropping
 - windowing
- supports images sizes:
 - SXGA (1280x960)
- 58 bytes of embedded one-time programmable (OTP) memory for customer use
- ultra low power mode (ULPM)
- support for output formats:
 - 10/12-bit RGB-IR RAW
- two-wire serial bus control (SCCB)
- MIPI/LVDS serial output interface (1- or 2-lane)/DVP interface
- image quality control:
 - automatic black level calibration

OV9756



Ordering Information

- OV09756-H55A (RGB-Ir, lead-free, 55-pin CSP)

Product Specifications

- active array size: 1280 x 960
- lens size: 1/3"
- power supply:
 - core: 1.7 to 1.9V (1.8V nominal)
 - analog: 3.15 to 3.45V (3.3V nominal)
 - I/O: 1.7 to 1.9V (1.8V nominal)
- power requirements:
 - active: 166 mW
 - standby: 51 μW
 - XSHUTDN: 13 μW
- temperature range:
 - operating: -30°C to +85°C junction temperature
 - stable image: 0°C to +60°C junction temperature
- output interface: 2-lane MIPI/LVDS serial output/DVP parallel output
- output formats: 10/12-bit RGB-Ir RAW
- input clock frequency: 6 - 74.5 MHz
- lens chief ray angle: 9° linear
- maximum image transfer rate:
 - SXGA (1280x960): 60 fps
- sensitivity: 39.6 Ke-/Lux-sec
- max S/N ratio: 43.1 dB
- dynamic range: 73.4 dB @ 8x gain
- pixel size: 3.75 μm x 3.75 μm
- image area: 4860 μm x 3660 μm
- package dimensions: 6254 μm x 5194 μm

Functional Block Diagram

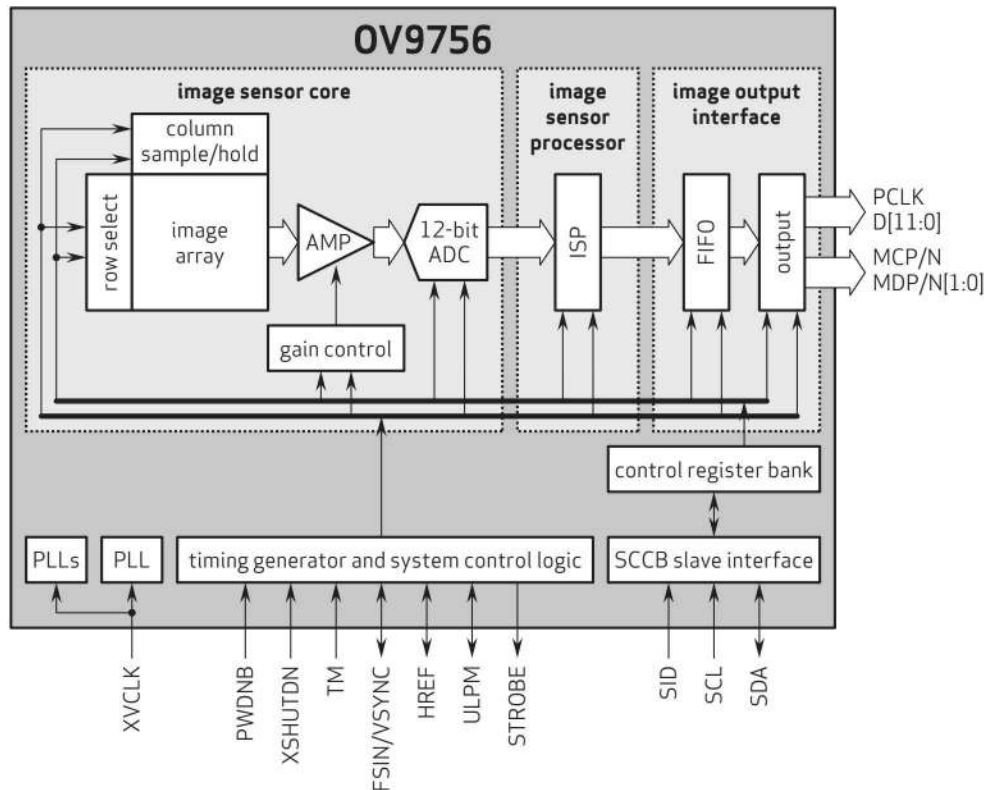

4275 Burton Drive
Santa Clara, CA 95054
USA

Tel: +1 408 567 3000
Fax: +1 408 567 3001
www.ovt.com

OmniVision reserves the right to make changes to their products or to discontinue any product or service without further notice. OmniVision and the OmniVision logo are registered trademarks of OmniVision Technologies, Inc. CameraChip and OmniPixel3-HS are trademarks of OmniVision Technologies, Inc. All other trademarks are the property of their respective owners.



OmniVision