

REVISIONS					
P	LTR	DESCRIPTION	DATE	DMN	APVD
G		REV PER ECO 17-001698	2-14-17	CT	DM

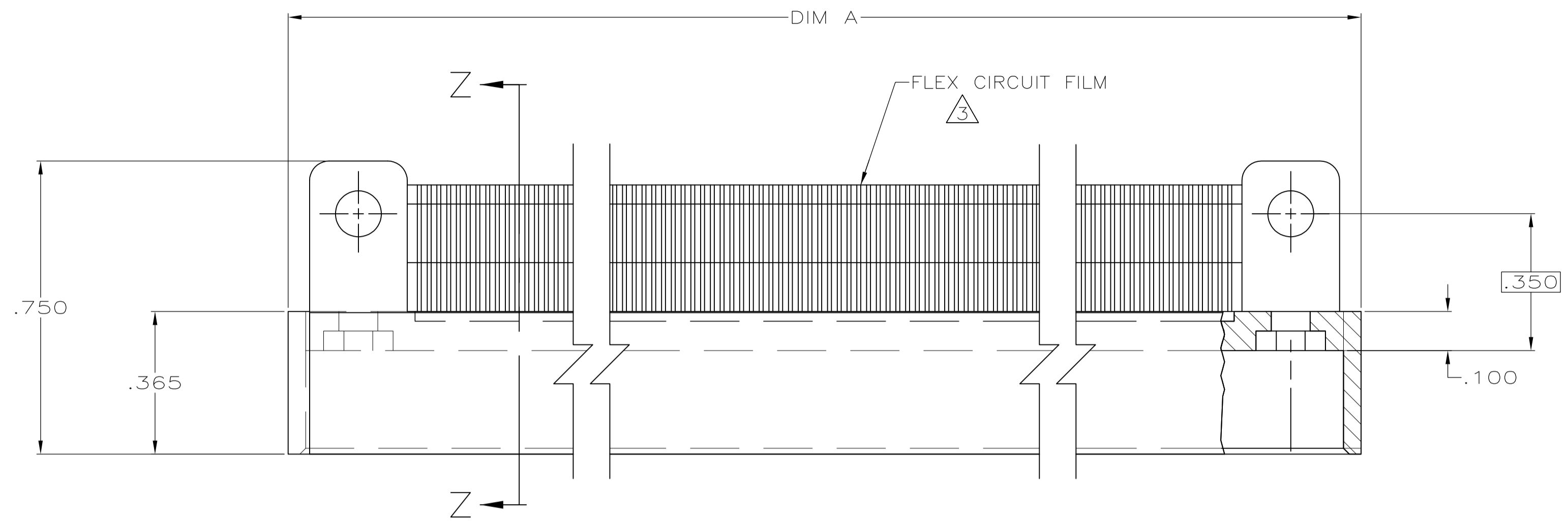

- 1 TE, PART NUMBER AND DATE CODE MARKED THIS SURFACE.
- 2 CAVITY I.D. NUMBERS MARKED ON ENDS, THIS SIDE ONLY (SEE TABLE)
- 3 FLEX CIRCUITS MATERIAL: 3.5 OUNCE (REF) BERYLLIUM COPPER PER QQ-C-530 CONDUCTORS WITH POLYIMIDE DIELECTRIC AND ACRYLIC ADHESIVE.
- 4 SIDE PLATES: STAINLESS STEEL PER QQ-S-763.
- 5 HOUSING MATERIAL: CRYSTAL POLYMER  
COLOR: GRAY  
CONTACT MATERIAL: COPPER ALLOY
- 6 EPOXY ADDED TO AREA AROUND FLEX. WILL NOT EXCEED HEIGHT OF BOARD STANDOFF.

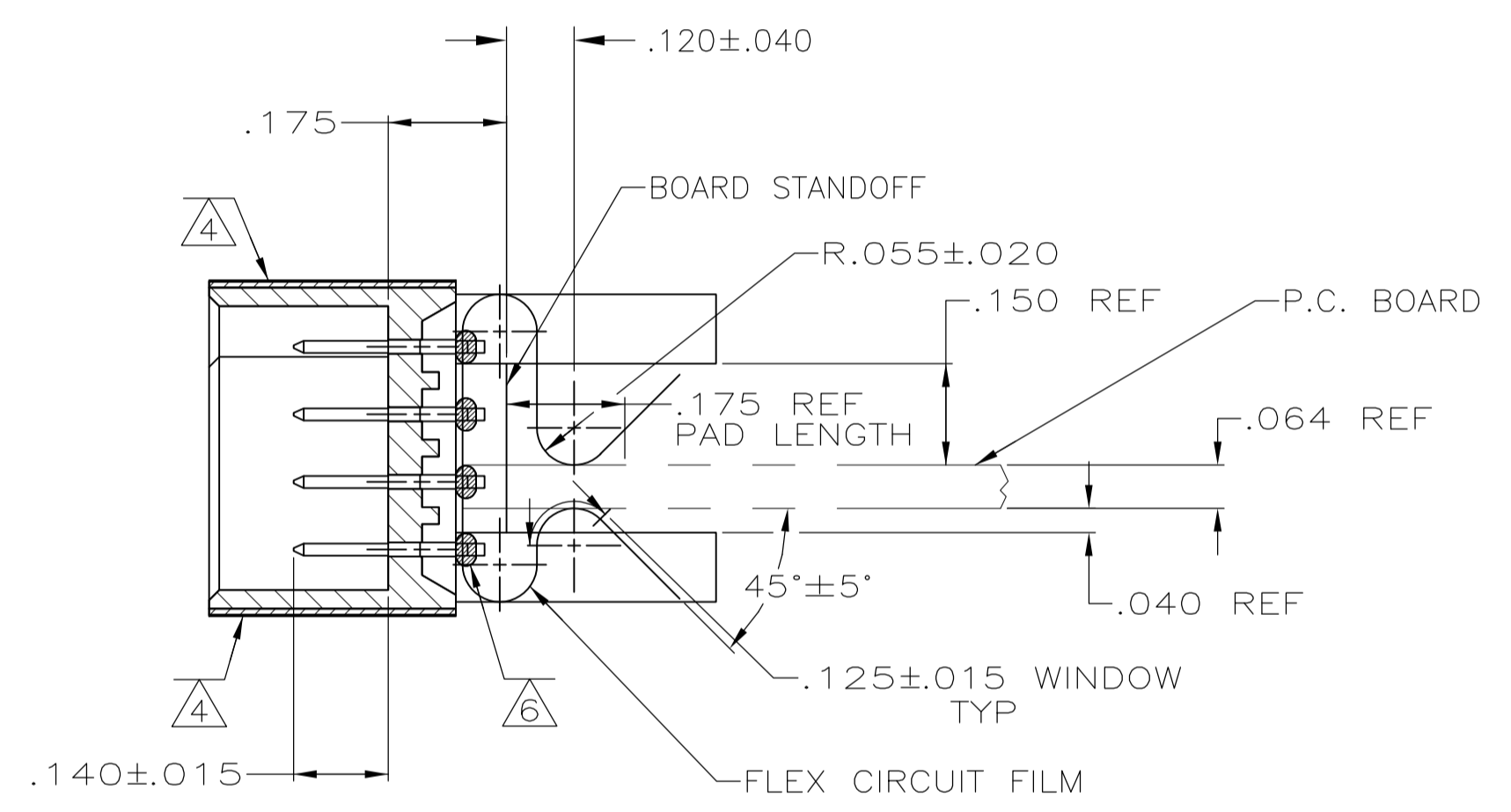
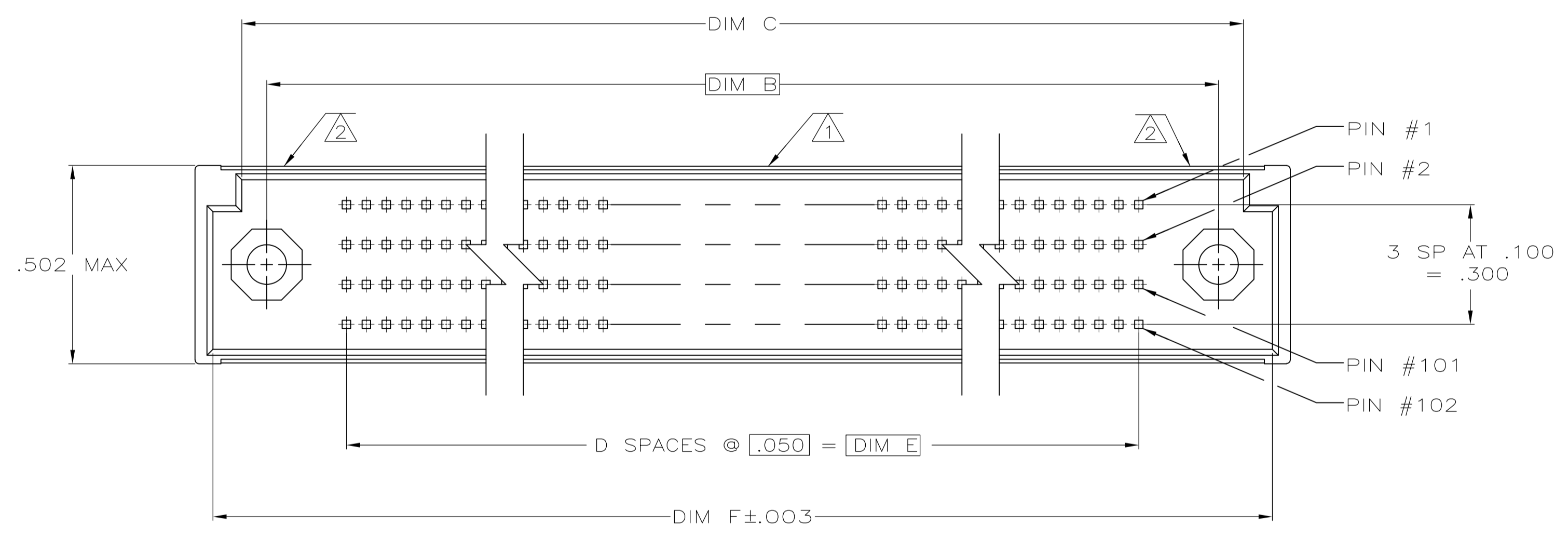

SECTION Z-Z

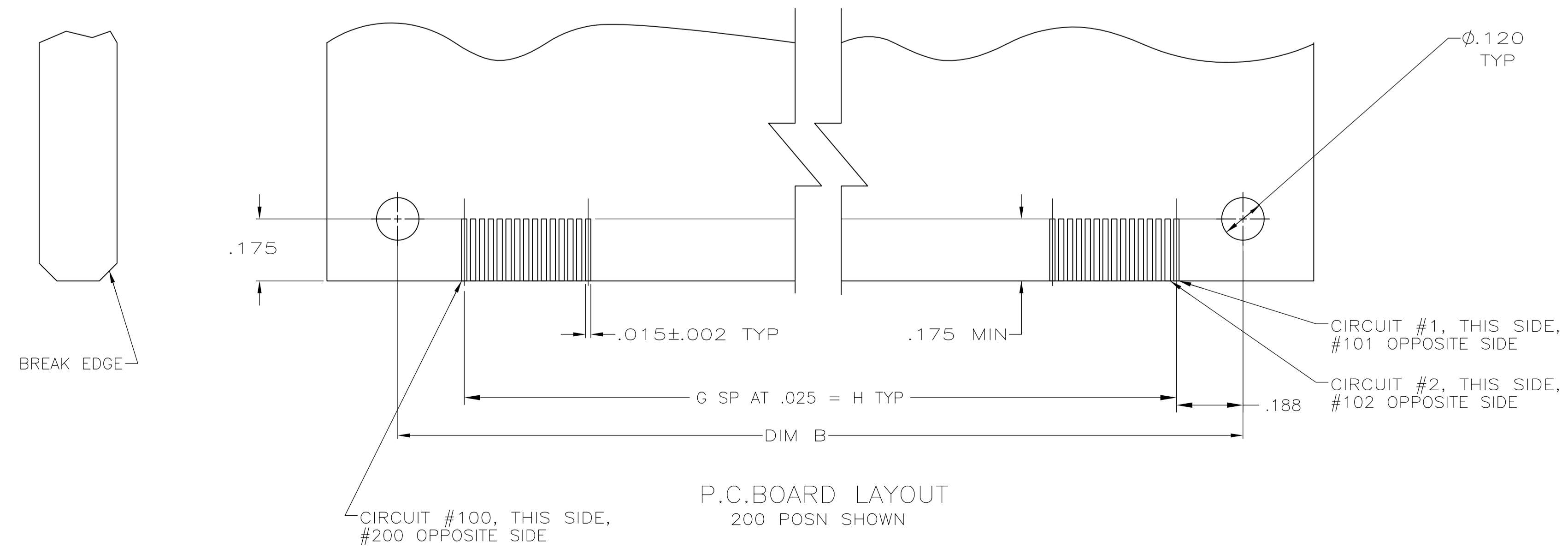

P.C. BOARD LAYOUT  
200 POSN SHOWN

1 - 150	3.725	149	4.355	3.700	74	4.225	4.100	4.460	300	448446-5
1 - 76	1.875	75	2.505	1.850	37	2.375	2.250	2.610	152	448446-4
1 - 160	3.975	159	4.605	3.950	79	4.475	4.350	4.710	320	448446-3
1 - 100	2.475	99	3.105	2.450	49	2.975	2.850	3.210	200	448446-2
1 - 60	1.475	59	2.105	1.450	29	1.975	1.850	2.210	120	448446-1
CAVITY IDENTIFICATION	DIM H	DIM G	DIM F	DIM E	D	DIM C	DIM B	DIM A	NUMBER OF POSITIONS	PART NUMBER

THIS DRAWING IS A CONTROLLED DOCUMENT.

DIMENSIONS: INCHES	TOLERANCES UNLESS OTHERWISE SPECIFIED:	DIN T. ALEXANDER 5-19-92	STE TE Connectivity
0 PLC ± -	1 PLC ± -	CHK D. GUTTER 5-19-92	NAME PIN ASSY 4 ROW MINI-BOX
2 PLC ± -	3 PLC ± .005	APVD D. GUTTER 5-19-92	SIZE CAGE CODE DRAWING NO
4 PLC ± -	ANGLES ± -	PRODUCT SPEC	RESTRICTED TO
MATERIAL 5	FINISH .00050 MIN GOLD IN	APPLICATION SPEC	WEIGHT 0.000000
		SCALE 4:1	SHEET 1 OF 1
		CUSTOMER DRAWING	REV G