

PI3EQX16621

16Gbps, 4-Channels PCIe Mux ReDriver

Features

- 16Gbps Serial Link with Linear Equalizer
- Full Compliancy to PCIe Gen 1 to Gen 4 Standard
- Supporting Four Differential Channels
- 2 to 1 Mux
- Adjustable Output Linear Swing, Flat Gain, and Equalization via Pin Control
- 100Ω Differential CML I/Os
- Automatic Receiver Detect
- Rate and Coding Agnostic
- Transparent to Link Training
- Supply Voltage 3.3V
- Temperature Range: 0°C to 70°C
- Totally Lead-Free & Fully RoHS Compliant (Notes 1 & 2)
- Halogen and Antimony Free. "Green" Device (Note 3)
- Packaging (Pb-free & Green):
 - 40-Contact, ZLD40 (TQFN)

Block Diagram

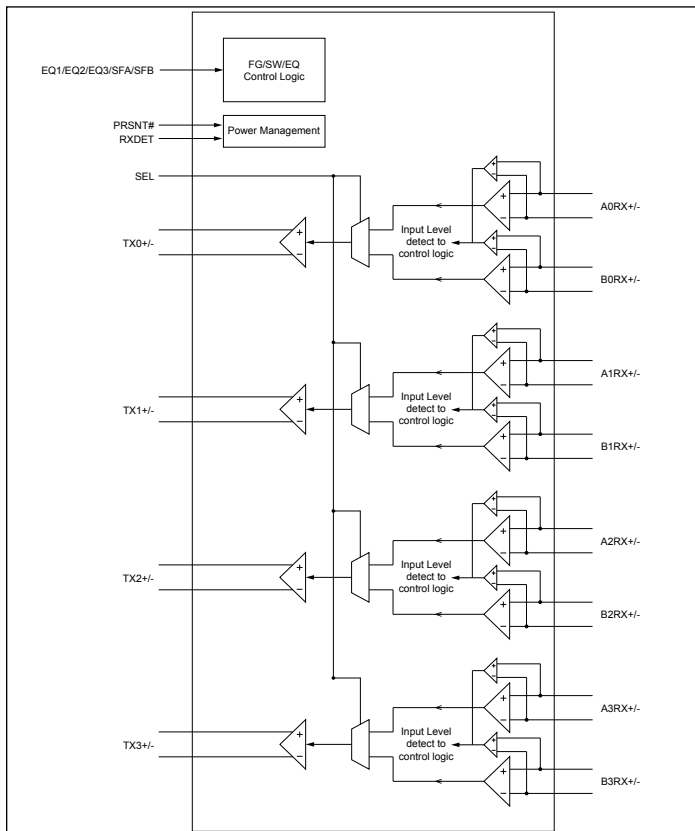

Description

The PI3EQX16621 is a low-power, high-performance 16Gbps 4-channel Mux ReDriver™.

The 4-Channel Mux ReDriver

The ReDriver provides programmable equalization, swing, and flat gain to optimize performance over a variety of physical mediums by reducing intersymbol interference. The ReDriver supports two 100Ω differential CML data I/Os between the Protocol ASIC to a switch fabric, over cable, or to extend the signals across other distant data pathways on the user's platform.

The integrated equalization circuitry provides flexibility with signal integrity of the signal before the ReDriver. A low-level input signal detection and output squelch function is provided for each channel. Each channel operates fully independently. The channels' input signal level determines whether the output is active.

The ReDriver also includes an adaptive power management feature to maximize battery life for power-sensitive consumer devices.

Applications

- High End Motherboard
- Workstation

Ordering Information

Part Number	Package	Description
PI3EQX16621ZLDEX	ZLD	40-Pin, 3mm × 6mm (TQFN)

Notes:

1. No purposely added lead. Fully EU Directive 2002/95/EC (RoHS), 2011/65/EU (RoHS 2) & 2015/863/EU (RoHS 3) compliant.
2. See <https://www.diodes.com/quality/lead-free/> for more information about Diodes Incorporated's definitions of Halogen- and Antimony-free, "Green" and Lead-free.
3. Halogen- and Antimony-free "Green" products are defined as those which contain <900ppm bromine, <900ppm chlorine (<1500ppm total Br + Cl) and <1000ppm antimony compounds.
4. E = Pb-free and Green
5. X suffix = Tape/Reel