

## TPiS 1T 1086 L5.5 / 7452



The TPiS 1T 1086 L5.5 is a thermopile sensor with integrated signal processing. It provides as a member of the CaliPile™ family factory calibration data stored in the sensors EEPROM. It features a confined field of view in an isothermal TO-39 package which ensure fast adaptation to ambient temperature changes. The technology of a high sensitive thermopile combined with a smart data treatment allows for much more than the traditional temperature measurement of remote objects. Once configured via the I<sup>2</sup>C interface an interrupt output can be used to monitor motion, presence or an over-temperature of remote objects.

One typical application is a remote object temperature monitoring with the feature of a fast over-temperature security switch. The temperature calculation is performed on the host based on the calibration parameters but the over-temperature recognition is constantly monitored by the sensor it-self.

## Product Specification

### Features

- Isothermal TO-39 package
- High sensitivity thermopile with 5° field-of-view
- Integrated 50 μW low-power signal processing
- I<sup>2</sup>C interface, hardware-configurable address
- Calibration data for ambient and object temperature sensing
- Interrupt function for presence, motion, over-temperature and more

### Applications

- Optimal for remote temperature measurement
- Fast remote over-temperature protection
- Near-field human presence sensing
- Far-field human motion detection

# Contents

<b>1</b>	<b>Dimensions and Connections</b>	<b>3</b>
<b>2</b>	<b>Optical Characteristics</b>	<b>4</b>
<b>3</b>	<b>Absolute Maximum Ratings</b>	<b>5</b>
<b>4</b>	<b>Device Characteristics</b>	<b>5</b>
<b>5</b>	<b>I<sup>2</sup>C Interface Characteristics</b>	<b>8</b>
5.1	START and STOP conditions . . . . .	8
5.2	Clock low extension . . . . .	9
5.3	Slave Address . . . . .	9
5.4	Protocol diagram description . . . . .	9
5.5	General Call . . . . .	9
5.6	Reading Data from the Register . . . . .	10
5.7	Writing Data to Register . . . . .	10
5.8	Reading EEPROM . . . . .	11
<b>6</b>	<b>Data processing characteristics</b>	<b>12</b>
6.1	Control and Status Registers . . . . .	12
6.2	Control Register Details . . . . .	13
<b>7</b>	<b>Internal processing overview</b>	<b>17</b>
7.1	Object and Ambient Temperatures . . . . .	17
7.2	Presence detection . . . . .	17
7.3	Motion detection . . . . .	18
7.4	Ambient temperature shock detection . . . . .	19
7.5	Object temperature over or under limit detection . . . . .	20
7.6	Hysteresis . . . . .	20
<b>8</b>	<b>Temperature Measurement</b>	<b>21</b>
8.1	Calibration Conditions . . . . .	21
8.2	EEPROM content . . . . .	21
8.3	EEPROM Details . . . . .	21
8.4	Calculation of the Ambient Temperature . . . . .	23
8.5	Calculation of the Object Temperature . . . . .	23
<b>9</b>	<b>Integration instructions and recommendations</b>	<b>24</b>
9.1	PCB layout and Wiring Patterns . . . . .	24
9.2	Position . . . . .	24
<b>10</b>	<b>Packaging Specification</b>	<b>26</b>
<b>11</b>	<b>Statements</b>	<b>27</b>
11.1	Patents . . . . .	27
11.2	Quality . . . . .	27
11.3	RoHS . . . . .	27
11.4	Liability Policy . . . . .	27
11.5	Copyright . . . . .	27

## 1 Dimensions and Connections

Figure 1: Mechanical Dimensions (in mm) and the pin configuration. The A0 output is internally bond to GND. A short description is given in table 1.

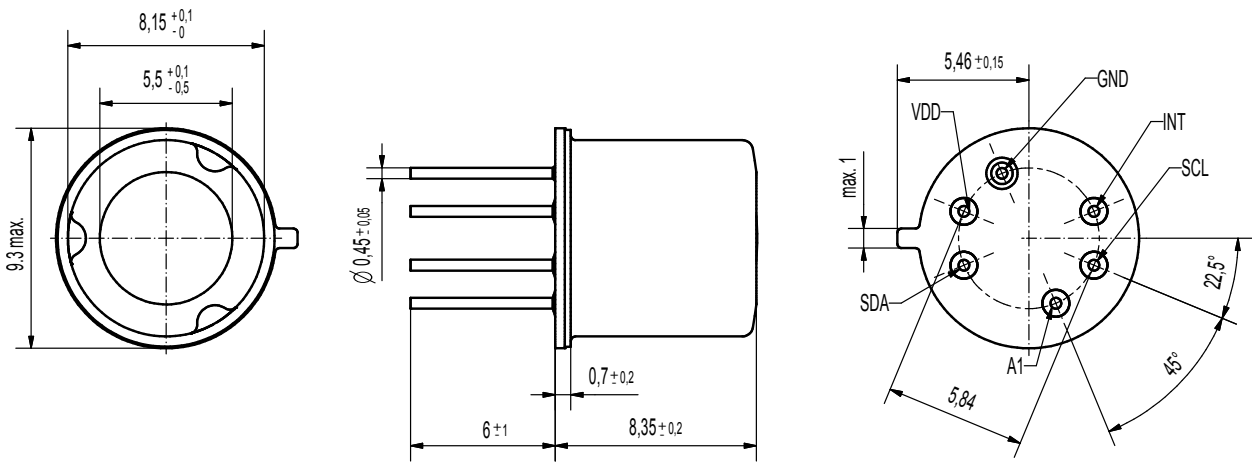

Table 1: Pin descriptions. Further explanations follow in this document.

Pin Symbol	Pin Name and short Functional Description.	Pin Type
A0,A1	<b>Address Inputs A0, A1:</b> Setting the last 2 bits of the slave address. Setting a pin to GND corresponds to 0. Setting a pin to VDD corresponds to a 1. The device address with both pins set to GND is <b>0x0C</b> .	Input
VSS	<b>Ground:</b> The ground (GND) reference for the power supply should be set to the host ground.	Power
VDD	<b>Power Supply:</b> The power supply for the device. Typical operating voltage is 3.3V	Power
SDA	<b>Serial Data:</b> The I <sup>2</sup> C bidirectional data line. Open-drain driven and requires pull-up resistors to min. 1.8V	Input/Output
SCL	<b>Serial Clock Input:</b> The I <sup>2</sup> C clock input for the data line. Up to 400 kHz are possible. The host must support clock stretching.	Input/Output
INT	<b>Interrupt Output:</b> The open drain / active low Interrupt output to indicate a detected event. Reading the chip register out resets this output.	Output

## 2 Optical Characteristics

Table 2: Optical characteristics

Parameter	Symbol	Min	Typ	Max	Unit	Remarks / Conditions
Focal length	f		5.5		mm	unpolished
Field of View X/Y	FOV X/Y		5		°	at 50 % intensity
Optical Axis		-3.7	0	3.7	°	
Distance to Spot	D:S		11.5:1			at 50 % intensity

Figure 2: Typical FoV measurement-result

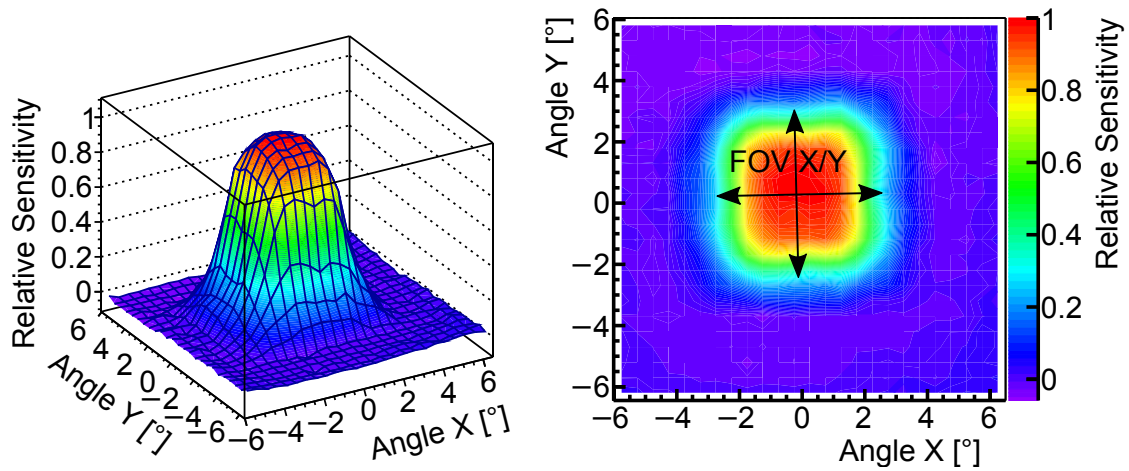
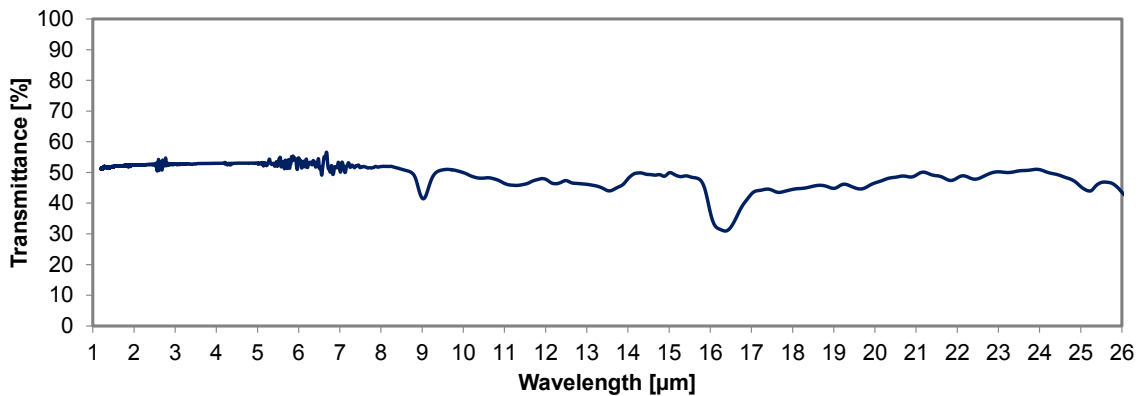

Table 3: Filter properties

Parameter	Symbol	Min	Typ	Max	Unit	Remarks / Conditions
Average Filter Transmittance	$T_A$		52		%	$7.5 \mu\text{m} < \lambda < 13.5 \mu\text{m}$

Figure 3: Filter transmittance, typical curve



### 3 Absolute Maximum Ratings

Table 4: Maximum Ratings

Parameter	Symbol	Min	Max	Unit	Remarks / Conditions
Operating Temperature	$T_0$	-20	85	°C	Electrical parameters may vary from specified values in accordance with their temperature dependence
Storage Temperature	$T_s$	-40	100	°C	Avoid storage in humid environment
Supply Voltage	VDD	-0.3	3.6	V	
Current to any pin		-100	100	mA	One pin at a time

### 4 Device Characteristics

Device characteristics are given at 25°C ambient temperature unless stated otherwise.

Table 5: Power Supply

Parameter	Symbol	Min	Typ	Max	Unit	Remarks / Conditions
Operating Voltage	VDD	2.6	3.3	3.6	V	
Supply Current	IDD			15	µA	VDD=3.3V

Table 6: Thermopile

Parameter	Symbol	Min	Typ	Max	Unit	Remarks / Conditions
Sensitive Area	A		0.16		mm <sup>2</sup>	Absorber 0.41 × 0.41 mm <sup>2</sup>
Sensitivity	$\Delta\text{counts}/\Delta T$		30		counts/K	Tobj=40°C
Noise(peak-peak)			8		counts	Tobj=40°C
Time constant	$\tau$		15		ms	
Resolution			17		Bits	
Sensitivity		0.7	0.8	0.9	µV/count	
Offset		64 000	64 500	65 000	counts	
Max. Object Temp.	Tobj <sub>max</sub>		350		°C	Full FOV, $\epsilon > 99\%$

Table 7: Ambient temperature sensor (PTAT)

Parameter	Symbol	Min	Typ	Max	Unit	Remarks / Conditions
Resolution			15		Bits	
Slope			170		counts/K	-20°C to 85°C
Range		-20		85	°C	
Linearity		-5		5	%	-20°C to 85°C
Offset		11 000	13 500	16 000	counts	
Noise(peak-peak)			5		counts	

**The calculation of a temperature has to be performed on the host system and is described in section 8.**

Figure 4 shows calculated thermopile raw data  $U = TP_{\text{object}}$  as a function of the ambient temperature and object temperature based on typical characteristics of TPiS 1T 1086 L5.5 . The ASIC typically features a wider

Figure 4: Typical temperature dependence of the raw thermopile output

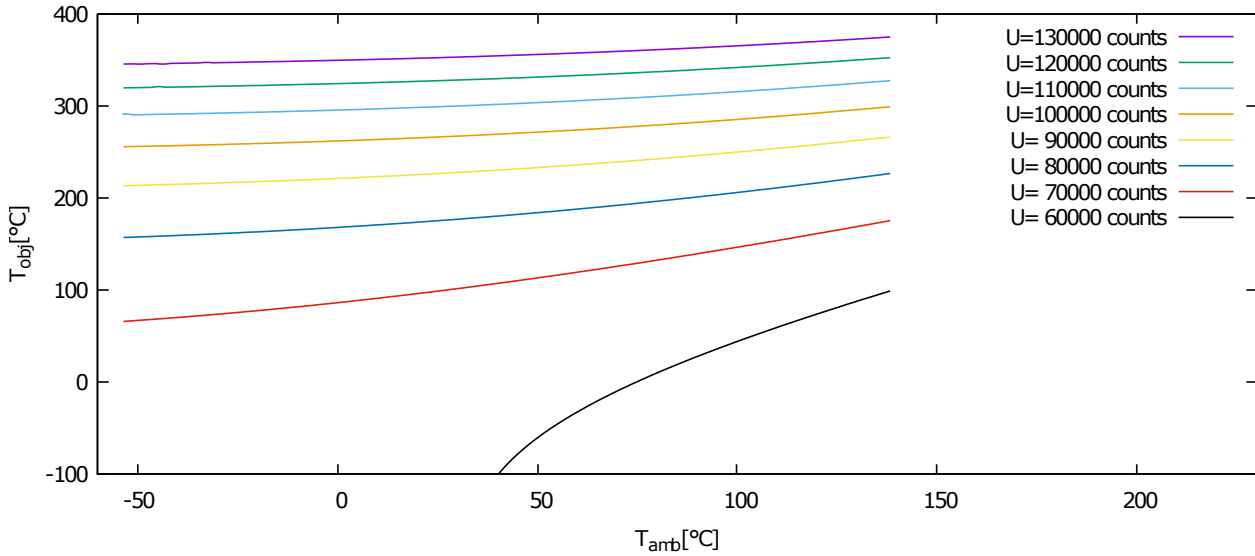

dynamic range as compared to the specified values in table 6 and 7. Values out of our specifications are not guaranteed.

Table 8: Calibration Conditions and Temperature Measurement Specifications

Parameter	Symbol	Min	Typ	Max	Unit	Remarks / Conditions
Distance to black body (BB)	d		30		mm	
Calib. Temp. $T_{BB=Obj}$			100		°C	
Calib. Temp. $T_{Amb}$			25		°C	
Accuracy $T_{Obj}$			±0.5		°C	@ Calib. Temp.
Precision $T_{Obj}$			< 0.1		°C	
Accuracy $T_{Obj}$			±3		°C	$40 < T_{Obj} [°C] < 250$
Precision $T_{Amb}$			< 0.1		°C	
Accuracy $T_{Amb}$			±1		°C	$10 < T_{Amb} [°C] < 80$

Table 8 gives an overview on the accuracy and precision of a remote temperature measurement which can be achieved with the factory calibration. Accuracy is the mean deviation of a measured value from the true value. The precision is the statistical uncertainty (RMS) of a measurement. The calibration parameters and conditions are described in section 8. The performance in the application may vary due to physical constraints. Significantly better performance is possible. For that the device must be re-calibrated after assembly in the end-application. Please consult our local representative for more information.

Table 9: Digital Interface (SCL, SDA, INT, A0, A1)

Parameter	Symbol	Min	Typ	Max	Unit	Remarks / Conditions
Input low voltage	$V_{IL}$	-	-	0.6	V	
Input high voltage	$V_{IH}$	1.5	-	-	V	
Output low voltage	$V_{OL}$	0.2	-	-	V	
Output high voltage	$V_{OH}$	-	-	VDD	V	Open Drain
Input leakage current	$I_{LI}$	-1	-	1	$\mu$ A	$V_I = VDD/2$
Output leakage current	$I_{LO}$	-	-	1	$\mu$ A	$V_O = VDD$
SCL Frequency	$F_{SCL}$	-	-	400	kHz	
SCL high time	$T_{HIGH}$	200	-	-	ns	
SCL low time	$T_{LOW}$	0.2	-	90*	$\mu$ s	*Slave clock stretching
refresh time		-	-	3	ms	





### 5.2 Clock low extension

Figure 7: Clock low extension

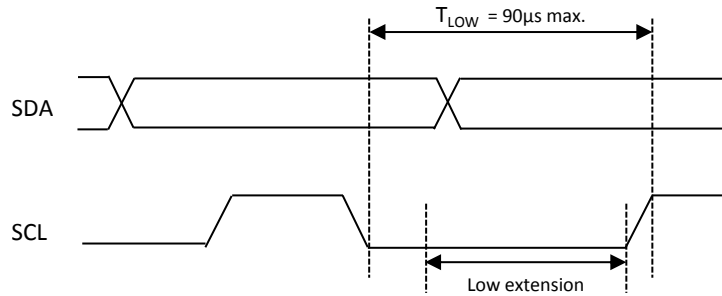

The CaliPile™ may need some time to process received data or may not be ready yet to send the next byte. In this case the SD can pull the SCL clock low to extend the low period of SCL and to signal to the master that it should wait (see figure 7). Once the clock is released the master can proceed with the next byte.

### 5.3 Slave Address

After power up the CaliPile™ responds to the General Call Address (0x00) only. Upon receipt of a general call, it loads its slave address from EEPROM (ESA<7:0>). The slave address stored in the EEPROM consists of 7 address bits (6:0) and 1 address control bit (7). If the address control bit is set, the slave address read from the EEPROM is merged with the information from the slave address select pins A1 and A0.

Table 10: Examples for the interplay between configuration pins and the EEPROM

ESA<7:0>	<A1:A0> state	I <sup>2</sup> C slave address
1000 1111	H:L	000 1110
1000 1100	H:L	000 1110
1000 1100	L:H	000 1101
0000 1100	L:H	000 1100
1ABC DEFG	Y:Z	ABC DEYZ
0ABC DEFG	Y:Z	ABC DEFG

Some examples are given in table 10. The CaliPile™ in the standard configuration has enabled configuration pins. The standard EEPROM content is **1000 1100**. The standard slave address is therefore dec12 or 000 1100 in binary representation when the address input pins A1,A0 are both connected to ground. Pulling A0 to a high level for example will result in the slave address dec13 or 000 1101.

### 5.4 Protocol diagram description

In the following chapters, the communication protocol will be illustrated with diagrams. Figure 8 describes the meaning of those diagrams.

### 5.5 General Call

In order to re-fresh the slave address from EEPROM the MD has to send a general call (0x00) followed by the reload command (0x04). The slave may require up to 300µs for copying the slave address from EEPROM information into the register.

Figure 8: Protocol diagram description

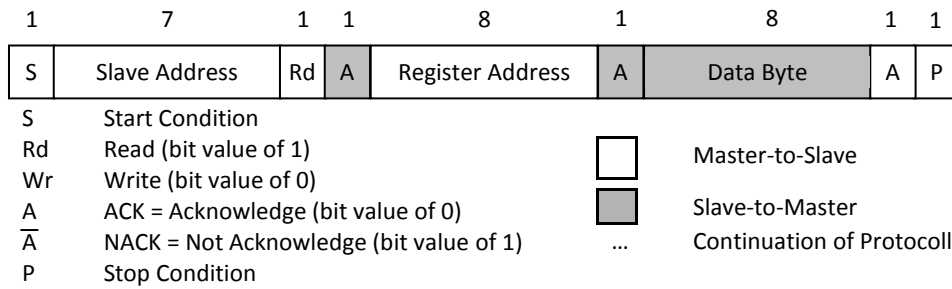
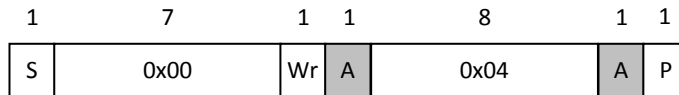

Figure 9: General call format



### 5.6 Reading Data from the Register

Each register can be read through the I<sup>2</sup>C bus interface. The address information following Slave address points to the register to be read. The SD may require some time to load the data into the serial interface and therefore apply "clock stretching" after reception of the address byte. Once the data is ready for transmission to the MD, clock-stretching will be released and the MD can clock out the data byte.

The address pointer on the SD will be automatically incremented to prepare for the next data byte to be fetched for transmission. The SD may apply "clock stretching" again to enforce a waiting time, before the next data byte is ready for transmission. The address pointer will wrap around to 0 once it exceeds address 63.

Reading of data can be interrupted by the MD at any time by generating a stop or a new start condition or a "not acknowledge". This is illustrated in figure 10.

Figure 10: Register read format



### 5.7 Writing Data to Register

Each register can be written to through the I<sup>2</sup>C bus interface. The address information following the Slave address specifies the location, where the next data byte is written to. The SD may require some time to write the data into the registers on chip and therefore apply "clock stretching" after reception of the data byte. Once the data is stored in the register, the slave will increment the address pointer and prepare for the next data byte to be received. The address pointer will wrap around when it exceeds 63.

Writing of data can be interrupted at any time by generating a stop or a new start condition or a "not acknowledge". This is illustrated in figure 11.

If the address points to a non-writable register, the register content remains unchanged.

Figure 11: Register write format

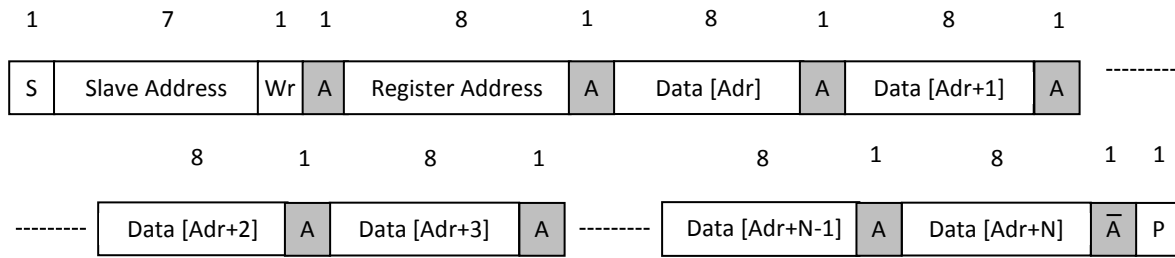

### 5.8 Reading EEPROM

A dedicated EEPROM control register (ECR) is provided to control access mode and to allow testing of EEPROM during production. Prior to reading EEPROM memory via I2C interface the control byte needs to be set accordingly. It is of importance to configure the EEPROM control register correctly as specified to ensure correct operation. In order to enable EEPROM reading, the ECR must be set to 0x80 as depicted in figure 12.

Figure 12: Configuring register for EEPROM readout

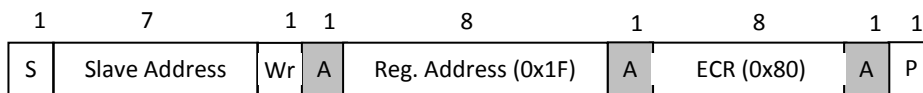

**Note:** Configuring the ECR for EEPROM read access causes increase of the supply current during EEPROM read operation until ECR will be set to 0x00 again.

Once the ECR has been setup correctly for read operation, the EEPROM cells can be addressed and read as drawn to figure 13.

Figure 13: Reading EEPROM



The address information following the Slave address points to the EEPROM memory location to be read. The SD may require some time to load the data into the serial interface and therefore apply "clock stretching" after reception of the address byte. Once the data is ready for transmission to the MD, clock stretching will be released and the MD can clock out the data byte.

The address pointer on the SD will be automatically incremented to prepare for the next data byte to be fetched for transmission. The SD may apply "clock stretching" again to enforce a waiting time, before the next data byte is ready for transmission. The address pointer will wrap around to 0 once it exceeds address 63.

The EEPROM control register must be configured to 0x00 after the end of the EEPROM read operation to bring the supply current back to normal (lower) level.

## 6 Data processing characteristics

### 6.1 Control and Status Registers

Table 11: Register content

Register #	Description	Size[bit]	Access
0	reserved	8	-
1-2,3[7]	TP <sub>object</sub>	17	Read
3[6:0],4	TP <sub>ambient</sub>	15	Read
5-7[7:4]	TP <sub>ObjLP1</sub>	20	Read
7[3:0]-9	TP <sub>ObjLP2</sub>	20	Read
10-11	TP <sub>ambLP3</sub>	16	Read
12-14	TP <sub>ObjLP2</sub> frozen	24	Read
15	TP <sub>presence</sub>	8	Read
16	TP <sub>motion</sub>	8	Read
17	TP <sub>amb shock</sub>	8	Read
18[7:0]	Interrupt Status	8	Read(Autoclear)
19[7:0]	Chip Status	8	Read
20[3:0]	S <sub>LP1</sub>	4	Write/Read
20[7:4]	S <sub>LP2</sub>	4	Write/Read
21[3:0]	S <sub>LP3</sub>	4	Write/Read
21[7:4]	reserved	4	-
22	TP <sub>presence</sub> threshold	8	Write/Read
23	TP <sub>motion</sub> threshold	8	Write/Read
24	TP <sub>amb shock</sub> threshold	8	Write/Read
25[4:0]	Interrupt Mask Register	5	Write/Read
25[7:5]	reserved	3	-
26[1:0]	Cycle time for Motion differentiation	2	Write/Read
26[3:2]	SRC select for presence determination	2	Write/Read
26[4]	TP <sub>OT</sub> direction	1	Write/Read
26[7:5]	reserved	3	-
27[7:0]	Timer interrupt	8	Write/Read
28,29	TP <sub>OT</sub> threshold	16	Write/Read
30	reserved	8	-
31	EEPROM control	8	Write/Read
62:32	EEPROM content	248	Read
63	Slave address	8	Read

The control and status registers in table 11 give access to the variables of the integrated CaliPile™ ASIC. Details on the registers are given in the following section 6.2.

While some registers contain computed values other contain parameters to control the functionality of the chip which is described in section 7.

**The register control values are undefined after power-up and require an initialization procedure for a well-defined operation of the CaliPile™.**

## 6.2 Control Register Details

TP <sub>object</sub>																							
Register #1[7:0]								Register #2[7:0]								Register #3[7]							
7	6	5	4	3	2	1	0	7	6	5	4	3	2	1	0	7	-	-	-	-	-	-	-

Contains the 17 bit TP<sub>object</sub> raw ADC value in digits. This represents the current signal of the thermopile sensor element.

TP <sub>ambient</sub>															
Register #3[6:0]								Register #4[7:0]							
-	6	5	4	3	2	1	0	7	6	5	4	3	2	1	0

Contains the 15 bit TP<sub>ambient</sub> raw value in digits. This represents the current signal of the ambient temperature sensor (PTAT).

TP <sub>objectLP1</sub>																							
Register #5[7:0]								Register #6[7:0]								Register #7[7:4]							
7	6	5	4	3	2	1	0	7	6	5	4	3	2	1	0	7	6	5	4	-	-	-	-

Contains the 20 bit TP<sub>objLP1</sub> value in digits. This represents the low-pass-filtered value of the TP<sub>object</sub> signal. To compare it with the 17 bit wide TP<sub>object</sub> divide the value by  $2^3 = 8$ . The filter time constant for this filter stage can be set with S<sub>LP1</sub>.

TP <sub>objectLP2</sub>																							
Register #7[3:0]							Register #8[7:0]							Register #9[7:0]									
-	-	-	-	3	2	1	0	7	6	5	4	3	2	1	0	7	6	5	4	3	2	1	0

Contains the 20 bit TP<sub>objLP2</sub> value in digits. This represents the low-pass-filtered value of the TP<sub>object</sub> signal. To compare it with the 17 bit wide TP<sub>object</sub> divide the value by  $2^3 = 8$ . The filter time constant for this filter stage can be set with S<sub>LP2</sub>.

TP <sub>ambLP3</sub>															
Register #10[7:0]								Register #11[7:0]							
7	6	5	4	3	2	1	0	7	6	5	4	3	2	1	0

Contains the 16 bit TP<sub>ambLP3</sub> value in digits. This represents the low-pass-filtered value of the TP<sub>ambient</sub> signal. To compare it with the 15 bit wide TP<sub>ambient</sub> divide the value by  $2^1 = 2$ . The filter time constant for this filter stage can be set with S<sub>LP3</sub>.

TP <sub>objectLP2 frozen</sub>																							
Register #12[7:0]								Register #13[7:0]								Register #14[7:0]							
7	6	5	4	3	2	1	0	7	6	5	4	3	2	1	0	7	6	5	4	3	2	1	0

Contains the 24 bit TP<sub>objLP2 frozen</sub> value in digits. This represents the low-pass-filtered value of the TP<sub>object</sub> signal when motion was detected. To compare it with the 17 bit wide TP<sub>object</sub> divide the value by  $2^7 = 128$ . See section 7.3 for more details on the motion detection algorithm.

TP <sub>presence</sub>							
Register #15[7:0]							
7	6	5	4	3	2	1	0

Contains the 8 bit TP<sub>presence</sub> value in digits. It is the unsigned difference between two values which combination is steered with the "source select". The sign of the value is contained in the "chip status". See section 7.2 for details.

TP <sub>motion</sub>							
Register #16[7:0]							
7	6	5	4	3	2	1	0

Contains the 8 bit TP<sub>motion</sub> value in digits. It is the unsigned difference between two consecutive values of TP<sub>objectLP1</sub>. The sign of the value is contained in the "chip status". The interval is steered with the "cycle time". See section 7.3 for details.

TP <sub>amb shock</sub>							
Register #17[7:0]							
7	6	5	4	3	2	1	0

Contains the 8 bit TP<sub>amb shock</sub> value in digits. It is the unsigned difference between TP<sub>ambient</sub> and TP<sub>ambL1</sub>. The sign of the value is contained in the "chip status". See section 7.4 for details.

Interrupt status							
Register #18[7:5] sign			Register #18[4:0] flag				
7	6	5	4	3	2	1	0
TP <sub>presence</sub>	TP <sub>motion</sub>	TP <sub>amb shock</sub>	TP <sub>OT</sub>	TP <sub>presence</sub>	TP <sub>motion</sub>	TP <sub>amb shock</sub>	timer

Each fulfilled interrupt condition between the last readout and the current one is stored here. See also "Chip status" for the current status of the interrupt conditions. Reading this register clears the register (setting it to 0x00) and resets the physical interrupt output (release to high).

**Sign** is the sign bit to the corresponding unsigned 8 bit values when the interrupt condition of the corresponding interrupt calculation branches (see section 7) was fulfilled since the last readout of that register. A 0 represents a positive value and a 1 a negative value.

**Flag** Contains a 1 when a condition of the corresponding interrupt calculation branches was fulfilled since the last readout of that register.

**Timer** Contains a 1 when at least one period of the timer passed since the last readout of that register.

Chip status							
Register #19[7:5] sign			Register #19[4:0] flag				
7	6	5	4	3	2	1	0
TP <sub>presence</sub>	TP <sub>motion</sub>	TP <sub>amb shock</sub>	TP <sub>OT</sub>	TP <sub>presence</sub>	TP <sub>motion</sub>	TP <sub>amb shock</sub>	timer

**Sign** is the sign bit to the corresponding unsigned 8 bit values. A 0 represents a positive value and a 1 a negative value.

**Flag** represents the status of the corresponding interrupt calculation branches (see section 7). A 1 represents a full-filled condition for the interrupt.

**Timer** represents a flag toggling with the double frequency of the "timer interrupt".

This register is masked by the "Interrupt Mask" register to evaluate the condition for the physical interrupt output pin at the CaliPile™.

Low pass time constants S <sub>LP</sub>							
Register #20[7:4] LP2				Register #20[3:0] LP1			
7	6	5	4	3	2	1	0
reserved				Register #21[3:0] LP3			
-	-	-	-	3	2	1	0

Contains the time constants for the three low-pass filters LP1, LP2 and LP3 (see section 7). The possible settings and the corresponding values are denoted in table 12.

Table 12: Low pass settings for LP1, LP2 and LP3

$f_{cut\ off}[Hz]$	$1/(2\pi f)[s]$	select code [hex]	select code [bin]
$6.4 \times 10^{-1}$	0.25	D	1101
$3.2 \times 10^{-1}$	0.50	C	1100
$1.5 \times 10^{-1}$	1	B	1011
$7.9 \times 10^{-2}$	2	A	1010
$3.9 \times 10^{-2}$	4	9	1001
$1.9 \times 10^{-2}$	8	8	1000
$9.9 \times 10^{-3}$	16	5	0101
$4.9 \times 10^{-3}$	32	4	0100
$2.5 \times 10^{-3}$	64	3	0011
$1.2 \times 10^{-3}$	128	2	0010
$6.2 \times 10^{-4}$	256	1	0001
$3.1 \times 10^{-4}$	512	0	0000

TP <sub>presence</sub> threshold							
Register #22[7:0]							
7	6	5	4	3	2	1	0

Contains the unsigned 8 bit threshold value for TP<sub>presence</sub> in digits. Once the TP<sub>presence</sub> signal exceeds this threshold the corresponding presence flag will be set in the "chip status" register. See section 7.2 for details.

TP <sub>motion</sub> threshold							
Register #23[7:0]							
7	6	5	4	3	2	1	0

Contains the unsigned 8 bit threshold value for TP<sub>motion</sub> in digits. Once the TP<sub>motion</sub> signal exceeds this threshold the corresponding presence flag will be set in the "chip status" register. See section 7.3 for details.

TP <sub>amb shock</sub> threshold							
Register #24[7:0]							
7	6	5	4	3	2	1	0

Contains the unsigned 8 bit threshold value for TP<sub>amb shock</sub> in digits. Once the TP<sub>amb shock</sub> signal exceeds this threshold the corresponding presence flag will be set in the "chip status" register. See section 7.4 for details.

Interrupt Mask							
reserved			Register #25[4:0]				
-	-	-	4	3	2	1	0
-	-	-	TP <sub>OT</sub>	TP <sub>presence</sub>	TP <sub>motion</sub>	TP <sub>amb shock</sub>	timer

Contains the 5 bit mask value to activate the external interrupt output INT pin based on five different possible sources in the "chip status" register.

The INT pin will be activated only if the corresponding mask flag inside the interrupt mask register is set to 1 and the corresponding interrupt occurs as signaled in the "chip status" register.

- Bit[4]: set to 1 activates the INT pin if the TP<sub>OT</sub> flag in register "chip status" has been set
- Bit[3]: set to 1 activates the INT pin if the TP<sub>presence</sub> flag in register "chip status" has been set
- Bit[2]: set to 1 activates the INT pin if the TP<sub>motion</sub> flag in register "chip status" has been set
- Bit[1]: set to 1 activates the INT pin if the TP<sub>amb shock</sub> flag in register "chip status" has been set
- Bit[0]: set to 1 activates the INT pin if the timer flag in register "chip status" has been set

If more than one mask bit has been set the INT pin will be activated for whatever flag in the chip status register comes first (OR condition). The INT output will remain active until the host micro-controller reads the "interrupt status" register. Interrupts are set when conditions change from inactive (0) to active (1).

Interrupt Mask							
Register #26							
reserved			TP <sub>OT</sub> dir	[3:2] SRC select			[1:0] cycle time
-	-	-	4	3	2	1	0

**TP<sub>OT</sub> dir** allows to select in which direction TP<sub>object</sub> has to cross the TP<sub>OT</sub> threshold to create an interrupt.

If 1, an interrupt is created if TP<sub>object</sub> exceeds the TP<sub>OT</sub> threshold.

If 0, an interrupt is created if TP<sub>object</sub> falls below the TP<sub>OT</sub> threshold.

**SRC select** allows to switch the signal sources to be used for the TP<sub>presence</sub> calculation as explained further in section 7.2. Possible values are

00 = TP<sub>object</sub> – TP<sub>objLP2</sub>

01 = TP<sub>objLP1</sub> – TP<sub>objLP2</sub>

10 = TP<sub>object</sub> – TP<sub>objLP2</sub> frozen

11 = TP<sub>objLP1</sub> – TP<sub>objLP2</sub> frozen

**Cycle time** is the time between these two consecutive TP<sub>objLP1</sub> points to determine TP<sub>motion</sub>. This is explained further in section 7.3. Possible values are

00 = 30 ms

01 = 60 ms

10 = 120 ms

11 = 240 ms

Timer interrupt							
Register #27[7:0]							
7	6	5	4	3	2	1	0

Contains a timer overrun value from 30 ms up to 7.7 s in steps of 30 ms.

$$\text{Timer interval} = (1 + \text{Timer interrupt}) \cdot 30 \text{ ms}$$

TP <sub>OT</sub> threshold															
Register #28[7:0]								Register #29[7:0]							
7	6	5	4	3	2	1	0	7	6	5	4	3	2	1	0

Contains the 16 bit TP<sub>OT</sub> threshold value in digits. To compare this value to the 17 bit wide TP<sub>object</sub> please multiply this value by a factor of 2<sup>1</sup> = 2. More details are depicted in section 7.5.

EEPROM control register							
Register #31[7:0]							
7	6	5	4	3	2	1	0

Contains the EEPROM control bits. Set it to 0x80 in order to read the EEPROM through the register. **It should be set to 0x00 in case of no access to the EEPROM.** For more details please refer to section 5.8.



## 7 Internal processing overview

In order to explore the complex functionalities of our CaliPile™ products, we recommend to obtain one of our Demonstration Kits. Please ask our local representative for further advice.

Figure 14: A schematic overview on the internal processing paths and variables

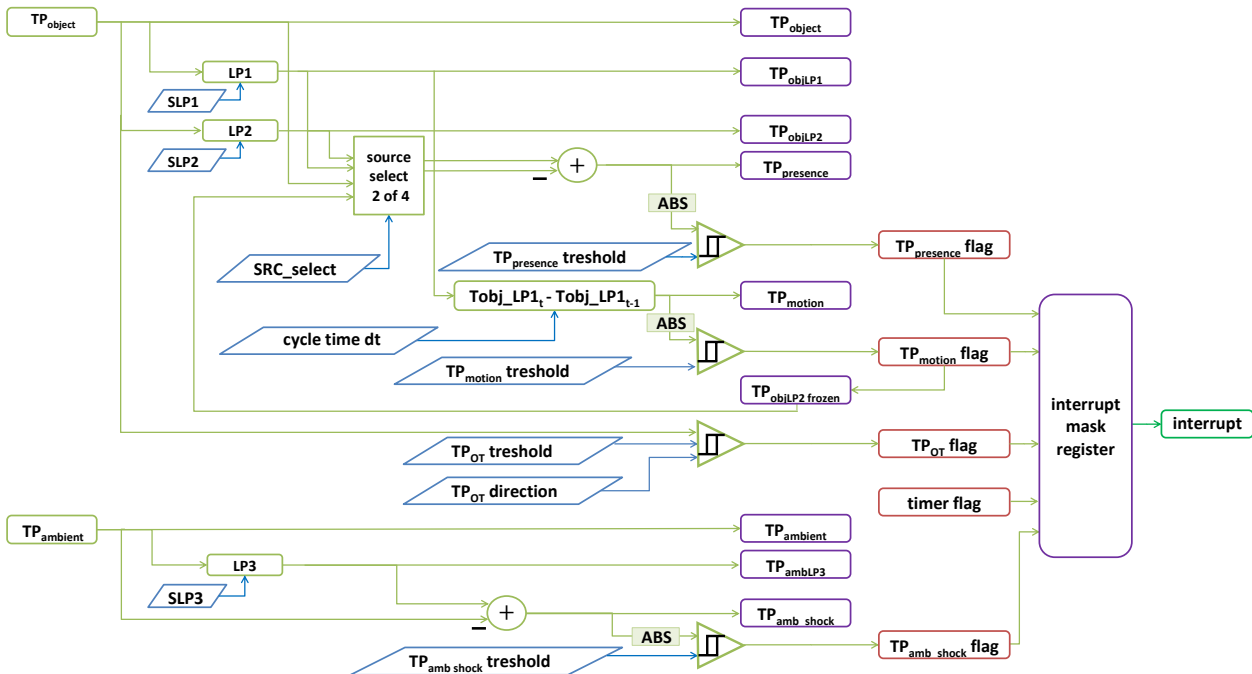

The Sketch 14 gives an overview on the internal CaliPile™ data processing algorithms. The CaliPile™ contains all functions required to allow an external micro-controller to detect activity and presence. The parameters which should lead for example to a wake-up of the host micro-controller can be programmed and adapted on the fly. The algorithm is based on various filter calculations of the sensor signals  $TP_{object}$  and  $TP_{ambient}$ , their differences and time derivatives.

The CaliPile™ offers 4 basic functions which are "presence detection", "motion detection", "ambient temperature shock detection" and "over temperature detection". Those functions can be selected by the host micro-controller as an interrupt source for wakeup. The parameters used to calculate the current state of "presence", "motion" or "shock" can be changed by the host controller through control registers. This allows the host controller to stay in sleep mode for most of the time and only be activated once the CaliPile™ detects a change which requires intervention.

### 7.1 Object and Ambient Temperatures

$TP_{object}$  and  $TP_{ambient}$  are the ADC raw data from the thermopile and the internal temperature reference PTAT.

To calculate the actual object temperature and ambient temperature a calculation is required on the host system based on the calibration constants from the CaliPile™'s EEPROM. Details are described in section 8. All other functionalities of the chip do not require an explicit knowledge of the actual temperatures as only relative changes are being processed. This allows a continuous operation of the CaliPile™ at a low power power consumption.

### 7.2 Presence detection

Presence detection is accomplished by observing the difference between two user selectable signal paths which will be calculated from the thermopile raw signal  $TP_{object}$  (see chart 15). In order to select the optimal application specific solution for presence detection, four signal path combinations are available for selection.

Figure 15: Presence detection algorithm chart

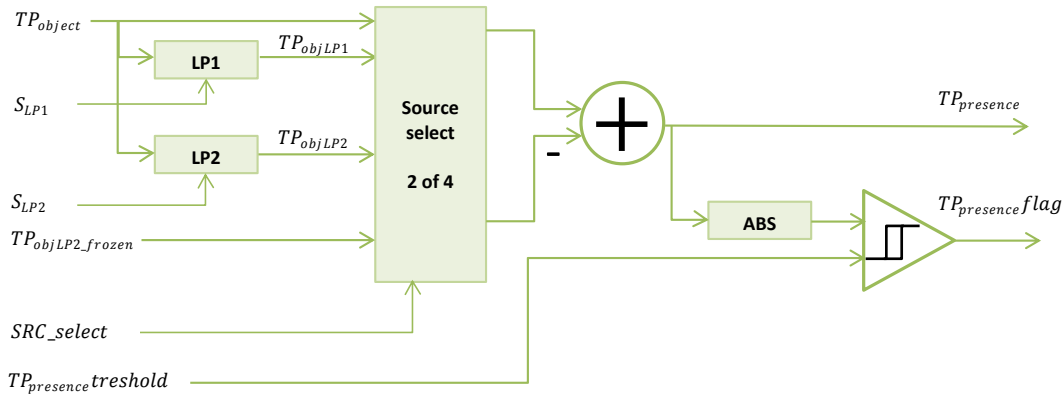

The original  $TP_{object}$  data as provided by the thermopile, two signals, which have been processed by low pass filters LP1 and LP2 with different user programmable time constants ( $S_{LP1}$ ,  $S_{LP2}$ ).

$$TP_{objLP1}(x) = TP_{object}(x) \cdot S_{LP1} + TP_{objLP1}(x - 1) \cdot (1 - S_{LP1})$$

$$TP_{objLP2}(x) = TP_{object}(x) \cdot S_{LP2} + TP_{objLP2}(x - 1) \cdot (1 - S_{LP2})$$

The signal  $TP_{ObjLP2\ frozen}$  which is the  $TP_{ObjLP2}$  output, that was saved at the moment the last motion event was detected.

Thus various calculations for presence detection are possible and can be adapted to the actual conditions e.g.:

$$TP_{presence} = TP_{object} - TP_{objLP2}$$

$$TP_{presence} = TP_{objLP1} - TP_{objLP2}$$

$$TP_{presence} = TP_{object} - TP_{objLP2\ frozen}$$

$$TP_{presence} = TP_{objLP1} - TP_{objLP2\ frozen}$$

The difference of those two selected signals paths is then compared with a programmable threshold  $TP_{presence\ threshold}$ . The  $TP_{presence}$  flag is set once the difference of the two signals exceeds the threshold.

**Recommended settings to start the evaluation with are:**

variable	value	meaning
$S_{LP1}$	bin 1011	1 s
$S_{LP2}$	bin 1000	8 s
SRC select	bin 01	$TP_{objLP1} - TP_{objLP2}$
$TP_{presence\ threshold}$	dec 50	$\pm 50$ counts
Interrupt Mask	bin 0000 1000	$TP_{presence}$

Other register values are not important for that parameter set.

### 7.3 Motion detection

Motion detection is accomplished by observing the difference between two consecutive samples of  $TP_{objLP1}$  with a programmable time interval  $dt$ . This is comparable to the 1<sup>st</sup> derivative of  $TP_{objLP1}$ .

$$TP_{motion} = \frac{dTP_{objLP1}}{dt}$$

The difference of the two signals paths is then compared with a programmable threshold  $TP_{motion\ threshold}$ . The  $TP_{motion}$  flag is set once the difference exceeds the threshold. This is illustrated in figure 16.

Figure 16: Motion detection algorithm chart

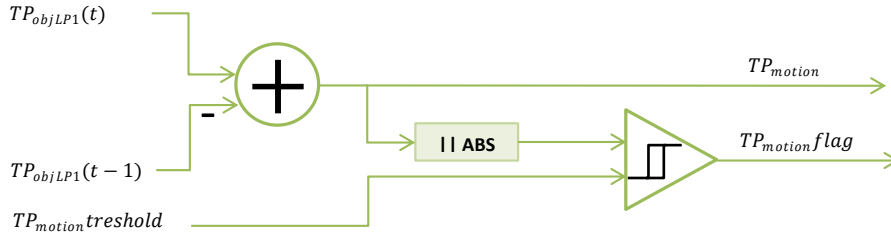

At the moment the  $TP_{motion}$  flag is set, the current value of  $TP_{objLP2}$  will be saved as  $TP_{objLP2} frozen$  for further use in the presence detection algorithm.

**Recommended settings to start the evaluation with are:**

variable	value	meaning
$S_{LP1}$	bin 1100	0.5 s
cycle time	bin 10	120 ms
$TP_{motion} threshold$	dec 10	$\pm 10$ counts
Interrupt Mask	bin 0000 0100	$TP_{motion}$

Other register values are not important for that parameter set.

It should be noticed that motion detection requires a fast change in the signal. It is thus suitable for small field-of-views in case of large distances to the sensor. To reduce the field-of-view of a sensor apply lens or aperture optics.

### 7.4 Ambient temperature shock detection

Figure 17: Ambient Temperature shock detection algorithm chart

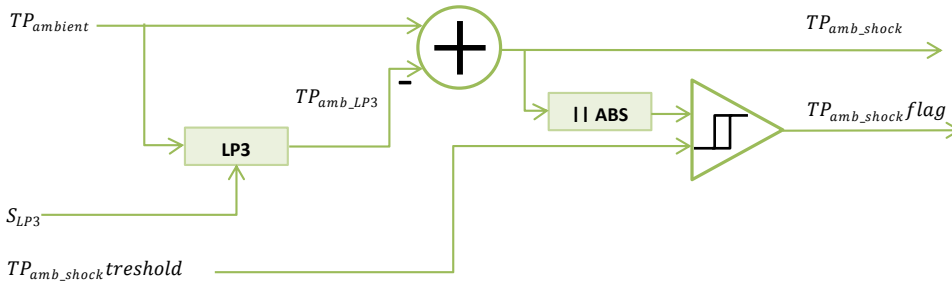

As shown in figure 17 the ambient temperature shock detection is accomplished by observing the difference between  $TP_{ambient}$  and the low pass filtered  $TP_{amb\_LP3}$ . The difference of the two signals will then compared with a programmable threshold  $TP_{amb\_shock} threshold$ . The  $TP_{amb\_shock} flag$  is set once the difference exceeds the threshold to indicate a sudden change in the ambient temperature.

**Recommended settings to start the evaluation with are:**

variable	value	meaning
$S_{LP3}$	bin 1010	2 s
$TP_{amb\_shock} threshold$	dec 10	$\pm 10$ counts
Interrupt Mask	bin 0000 0010	$TP_{amb\_shock}$

Other register values are not important for that parameter set.

Figure 18: Object temperature over or under limit detection algorithm chart

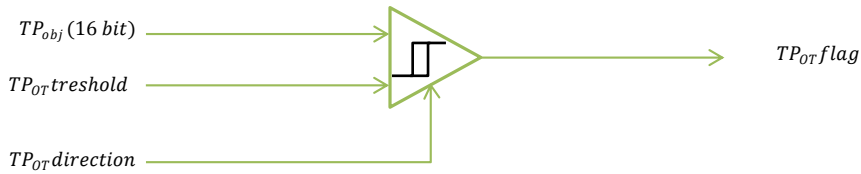

### 7.5 Object temperature over or under limit detection

The  $TP_{object}$  raw data is compared against the value specified in the object temperature threshold  $TP_{OT\text{ threshold}}$ . This is illustrated in figure 18. An event is generated whenever the object temperature crosses the threshold. The user can select by the use of the corresponding control registers, the condition which should lead to an interrupt: Exceeding the limit or falling below the limit.

The interrupt is cleared when the micro-controller reads the interrupt status register. A new interrupt can only be generated with a new event (object temperature crosses the threshold).

To ensure correct system start up, the over temperature flag is set and the interrupt output is switched active after the device has been powered up. This feature is achieved with an on chip power on reset.

**Note that  $TP_{object}$  is the thermopile raw value which does not necessarily correspond to one fixed object temperature. This is specially the case when the ambient temperature changes.** See also figure 4 for an illustration. To determine  $TP_{object}$  and/or a threshold for a given object temperature, refer to section 8.

### 7.6 Hysteresis

The calculations for  $TP_{presence}$ ,  $TP_{motion}$  and  $TP_{amb\ shock}$  apply a hysteresis of 12.5% of the actual threshold value. The minimum hysteresis value is fixed to 5 counts. That means that the actual value must fall below the threshold by 12.5% of the threshold or at least by 5 counts in order to change the corresponding "chip status" bit to 0.

For the object temperature over/under limit detection  $TP_{OT}$  threshold there is a fixed hysteresis of 64 counts built into the threshold comparator. This is large enough to suppress the noise on the signals and to prevent false or frequent triggering of the corresponding flags if the signal is close to the threshold. It may lead to confusion when for example extremely small amplitudes are being evaluated which in turn require small thresholds.

## 8 Temperature Measurement

### 8.1 Calibration Conditions

The thermopile output is related to the net IR-radiation. The net IR-radiation can be correlated with the object temperature for a specific fixed set-up. The set-up valid for the factory calibration constants is shown in sketch 19.

Figure 19: Calibration conditions

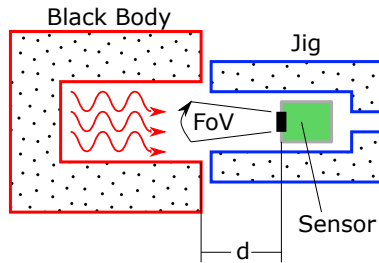

A silicon-oil immersed hollow black body with an inner diameter of 55 mm and an emissivity of better than 99% has a temperature  $T_{obj}$ . A temperature controlled jig with a inner diameter of 35 mm has a temperature  $T_{amb}$  and is coated with a black paint for an emissivity of better than 96%. The jig contains the TPiS 1T 1086 L5.5 sensor at a distance  $d$  to the black body. Numbers are specified in table 8. Conditions other than described in this document generally require a customized object calibration. Otherwise sensor performance may be different than specified here. Please contact our local representative for more details.

### 8.2 EEPROM content

Table 13: EEPROM content

Register#	EEPROM#	Name	Description	Content Example
32	0	PROTOCOL	EEPROM Protocol number	3
33,34	1,2	CHKSUM	Checksum of all EEPROM contents excluding cell 1,2	-
35 .. 40	3 .. 8	reserved	reserved	-
41	9	LOOKUP#	Identifier for look-up-table	2
42,43	10,11	PTAT25	Tamb output in digits at 25 °C	13 500
44,45	12,13	M	PTAT slope [digits/K]×100	17 200
46,47	14,15	$U_0$	TP offset, $U_0 - 32768$	31 732
48,49	16,17	$U_{OUT1}$	TP output for $T_{OBJ1}$ at 25 °C, $U_{out}/2$	32 475
50	18	$T_{OBJ1}$	$T_{OBJ}$ value in °C for $U_{OUT1}$	100
51 .. 62	19 .. 30	reserved	reserved	-
63	31	SLAVE ADD	I <sup>2</sup> C slave address with external addressing bit	140

### 8.3 EEPROM Details

PROTOCOL							
Register #32[7:0]							
7	6	5	4	3	2	1	0

Contains the 8 bit EEPROM Protocol number as a unique identifier. The default protocol number is 3.

CHSUM															
Register #33[7:0]								Register #34[7:0]							
7	6	5	4	3	2	1	0	7	6	5	4	3	2	1	0

Contains the 16 bit checksum in digits. The checksum is computed as a sum of all EEPROM cells excluding the checksum cells themselves (cell# 1,2).

LOOKUP#							
Register #41[7:0]							
7	6	5	4	3	2	1	0

Contains the 8 bit look-up-table identifier which defines the functional behaviour of that specific device. The default value for that product type is 2. For details please refer to section 8.5.

PTAT25															
Register #42[6:0]								Register #43[7:0]							
-	6	5	4	3	2	1	0	7	6	5	4	3	2	1	0

Contains the 15 bit  $TP_{ambient}$  value of the internal PTAT in digits at an ambient temperature of 25 °C. The first bit is unused and always 0. A typical value is 13 500 counts. For details please refer to section 8.4.

M															
Register #44[7:0]								Register #45[7:0]							
7	6	5	4	3	2	1	0	7	6	5	4	3	2	1	0

Contains the 16 bit slope value of the internal PTAT in digits per Kelvin scaled by a factor of 100.

$$M = \text{RegVal}/100$$

A typical slope is 172 counts/K. For details please refer to section 8.4.

$U_0$															
Register #46[7:0]								Register #47[7:0]							
7	6	5	4	3	2	1	0	7	6	5	4	3	2	1	0

Contains the 16 bit  $TP_{object}$  offset value of the thermopile subtracted by 32 768 counts.

$$U_0 = \text{RegVal} + 32768$$

A typical offset is 64 500 counts. For details please refer to section 8.5.

$U_{OUT1}$															
Register #48[7:0]								Register #49[7:0]							
7	6	5	4	3	2	1	0	7	6	5	4	3	2	1	0

Contains the 16 bit  $TP_{object}$  value of the thermopile divided by a factor of 2 when facing a black body with a temperature of  $T_{OBJ1}$  at an ambient temperature of 25 °C.

$$U_{OUT1} = \text{RegVal} \cdot 2$$

A typical value is 32 475 counts. For details please refer to section 8.5.

$T_{OBJ1}$							
Register #50[7:0]							
7	6	5	4	3	2	1	0

Contains the 8 bit value in °C for the black body giving the response of  $U_{OUT1}$ . A typical value is 100 °C. For details please refer to section 8.5.

SLAVE ADD							
Register #63							
[7]	[6:0]						
7	6	5	4	3	2	1	0
ADD PIN	I <sup>2</sup> C base address						

Contains the 7 bit I<sup>2</sup>C base address which is completed by the A0,A1 external pin settings when ADD PIN is set to 1. For details please refer to section 5.3.

### 8.4 Calculation of the Ambient Temperature

For a correct object temperature calculation the ambient temperature must be known. The temperature should be calculated in Kelvin and not °C. To calculate the ambient temperature out of  $TP_{ambient}$  the following formula can be applied.

$$T_{amb}[K] = (25 + 273.15) + (TP_{ambient} - PTAT25) \cdot (1/M)$$

using the calibration constants PTAT25 and M from the EEPROM.

The inverse to calculate an expected PTAT value for a given temperature  $T_{amb}$  is given by

$$TP_{ambient}[counts] = [T_{amb} - (25 + 273.15)] \cdot M + PTAT25$$

### 8.5 Calculation of the Object Temperature

The thermopile output signal  $TP_{object}$  is not only depending on the objects temperature but also on the ambient temperature  $T_{amb}$  as demonstrated in figure 4. To obtain the object temperature  $T_{obj}$  calculate

$$T_{object}[K] = F \left[ \frac{TP_{object} - U_0}{k} + f(T_{amb}) \right]$$

where  $T_{amb}$  is obtained as discussed in section 8.4.  $k$  is a scaling/calibration factor given by

$$k = \frac{U_{out1} - U_0}{[f(T_{obj1}) - f(25 + 273.15)]}$$

and contains the emissivity  $\epsilon$  of the object as well as the field-of-view coverage factor  $\Theta$ . Since our devices are calibrated for a full FOV coverage ( $\Theta = 1$ ) and an object emissivity of nearly  $\epsilon = 1$ , this factor has to be scaled properly to adjust for a different object property in the application by

$$k \mapsto k \cdot (\epsilon \cdot \Theta)$$

with  $\epsilon$  and  $\Theta$  in the range of 0 to 1.  $f(x)$  is in the simplest case an exponential with the exponent defined by the identifier LOOKUP#.

$$f(x) = x^{4.2} \text{ if LOOKUP\# = 2}$$

It's reverse function  $F(x)$  is then

$$F(x) = \sqrt[4.2]{x} \text{ if LOOKUP\# = 2}$$

Moreover  $U_0$ ,  $U_{out1}$  and  $T_{obj1}$  are calibration parameters from the EEPROM.

To predict a thermopile output based on the object temperature  $T_{object}$  and ambient temperature  $T_{amb}$  calculate

$$TP_{object}[counts] = k \cdot [f(T_{object}) - f(T_{amb})] + U_0$$

Since exponents and roots are heavy operations to be performed on a micro-controller based system, we recommend to implement  $f(x)$  as a lookup table. An implementation in Object-C language can be provided upon request. You may contact our local representative for more details.

## 9 Integration instructions and recommendations

### 9.1 PCB layout and Wiring Patterns

In general, the wiring must be chosen such that crosstalk and interference to/from the bus lines is minimized. The bus lines are most susceptible to crosstalk and interference at the high levels because of the relatively high impedance of the pull-up devices.

If the length of the bus line on a PCB or ribbon cable exceeds 5 cm and includes the VDD and VSS lines, the wiring pattern must be:

SDA - VDD - VSS - SCL

and only if the VSS line is included we recommend

SDA - VSS - SCL

as a pattern. These wiring patterns also result in identical capacitive loads for the SDA and SCL lines. The VSS and VDD lines can be omitted if a PCB with a VSS and/or VDD layer is used.

If the bus lines are twisted-pairs, each bus line must be twisted with a VSS return. Alternatively, the SCL line can be twisted with a VSS return, and the SDA line twisted with a VDD return. In the latter case, capacitors must be used to decouple the VDD line to the VSS line at both ends of the twisted pairs.

If the bus lines are shielded (shield connected to VSS), interference will be minimized. However, the shielded cable must have low capacitive coupling between the SDA and SCL lines to minimize crosstalk.

The PCB design requires, an optimization procedure to achieve the best signal quality. As a starting point sketch 20 is given. Values for pull-up resistors must be replaced by matching ones, fitting the capacitive load of lines. In case of strong EMI observations additional RC-filtering components might be required at the sensor inputs and outputs which is not depicted in the sketch.

Figure 20: Exemplary wiring layout

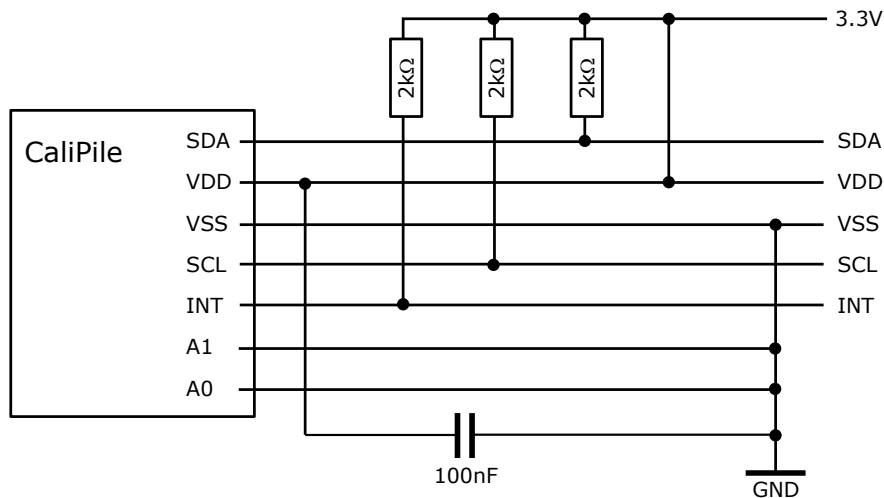

### 9.2 Position

In order to obtain the highest possible performance it is possible to operate the sensor without a (protecting) front window. To measure a temperature based on Excelitas calibration constants no window between the sensor and the object must be used. Excelitas calibration values are only valid when the bare sensor is exposed to the object.

As the device is equipped with a highly sensitive infra-red detector. It is sensitive any source of heat, direct or indirect. For a proper temperature measurement the device must be at the same temperature as the ambient. Sudden temperature changes will directly affect the behaviour of the internal calculations such as motion, presence and over-/under-temperature recognition. While slow variations of the sensor and ambient temperature



may be tolerated for a proper function of the motion and presence features, a drift in the ambient temperature needs to be compensated for the over-/under-temperature feature as mentioned in the corresponding section.

This device is equipped with a highly sensitive ADC and integrated circuits. Common rules of electronics integration apply. We recommend to place strong EMI sources far apart and/or to shield those.

## 10 Packaging Specification

The Excelitas Technologies tube packaging system protects the product from mechanical and electrical damage and is designed for manual unloading. The system consists of tubes which are protected against ESD. The devices are loaded sequentially and fixed with stoppers. Up to 50 parts are filled into one tube. In total up to 20 tubes are placed in one paper box. Information labels, ESD labels and bar-code Labels (optional) are placed on the box. Figure 21 shows the basic outline.

Figure 21: Tube packaging system for manual unload.

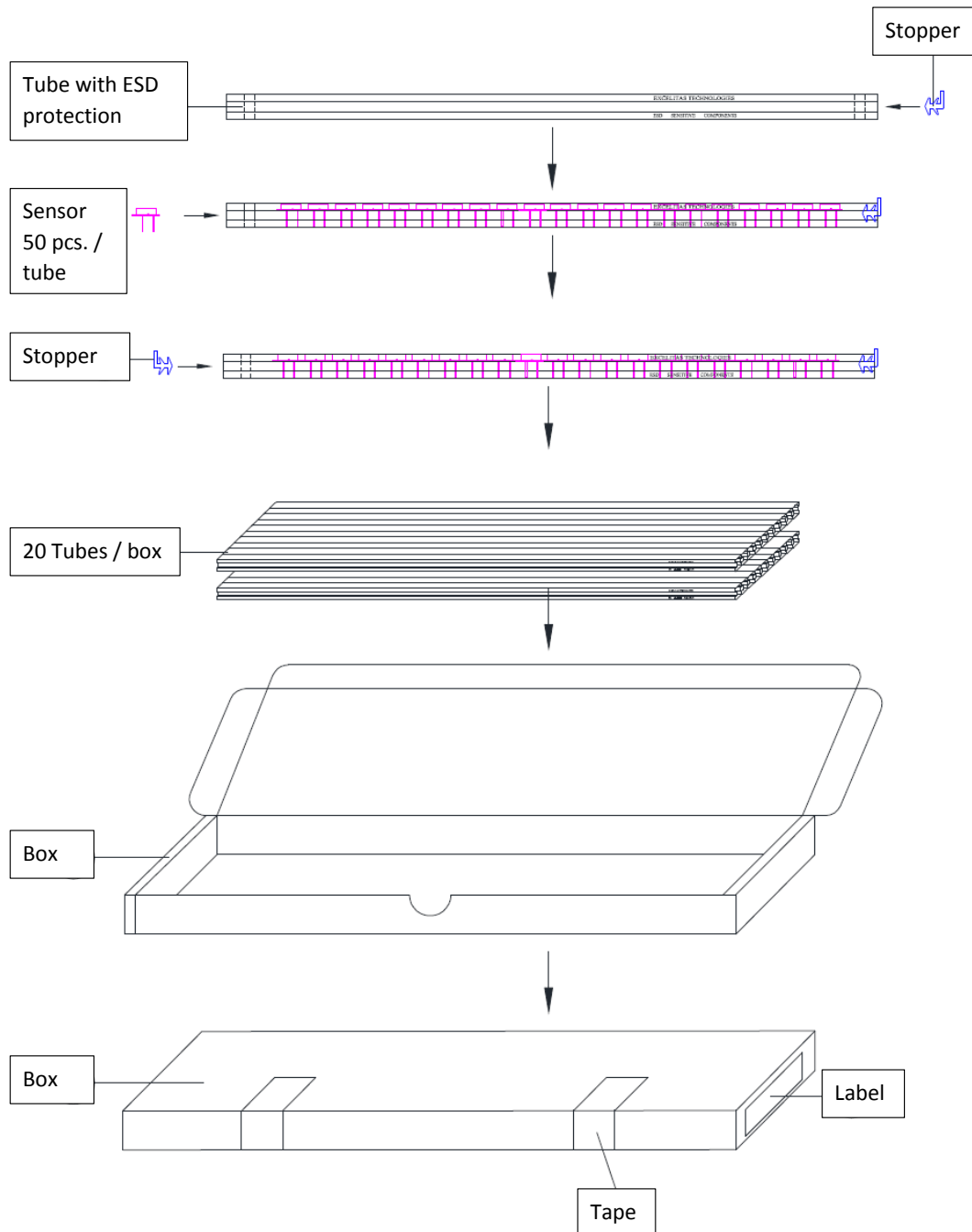

## 11 Statements

### 11.1 Patents

For several features of the CaliPile™ patents are pending.

### 11.2 Quality

Excelitas Technologies is an ISO 9001 certified manufacturer. All devices employing PCB assemblies are manufactured according to IPC-A-610 guidelines.

### 11.3 RoHS

This sensor is a lead-free component and complies with the current RoHS regulations, especially with existing road-maps of lead-free soldering.

### 11.4 Liability Policy

The contents of this document are subject to change without notice and customers should consult with Excelitas Technologies sales representatives before ordering. Customers considering the use of Excelitas Technologies thermopile devices in applications where failure may cause personal injury or property damage, or where extremely high levels of reliability are demanded, are requested to discuss their concerns with Excelitas Technologies sales representatives before such use. The Company's responsibility for damages will be limited to the repair or replacement of defective product. As with any semiconductor device, thermopile sensors or modules have a certain inherent rate of failure. To protect against injury, damage or loss from such failures, customers are advised to incorporate appropriate safety design measures into their product.

### 11.5 Copyright

This document and the product to which it relates are protected by copyright law from unauthorized reproduction. Notice to U.S. Government End Users The Software and Documentation are "Commercial Items", as that term is defined at 48 C.F.R. 2.101, consisting of "Commercial Computer Software" and "Commercial Computer Software Documentation," as such terms are used in 48 C.F.R. 12.212 or 48 C.F.R. 227.7202, as applicable. Consistent with 48 C.F.R. 12.212 or 48 C.F.R. 227.7202-1 through 227.7202-4, as applicable, the Commercial Computer Software and Commercial Computer Software Documentation are being licensed to the U.S. Government end users (a) only as Commercial Items and (b) with only those rights as are granted to all other end users pursuant to the terms and conditions herein. Unpublished rights reserved under the copyright laws of the United States.