

SENSOR CONFIGURATION

Sensor Model	Mounting	Input Voltage	Outdoor Rating/Low Temp	Color
WSP	SM Surface Mount EM End Mount	24V - Low Voltage (24VDC) UNV - 120/277/347VAC, 60Hz 208 - 208/240VAC 480 - 480VAC	Blank - Indoor Only	Blank - White BK - Black GY - Gray

Example:

WSPSMUNV Wasp Surface Mount Sensor, 120-347VAC

WSPSEMUNV Wasp End Mount Sensor, 120-347VAC,

SENSOR MODULE SPECIFICATIONS

Timer Timeouts:

- Primary (8 second test mode, 4, 8, 16, 30 minutes)
- Secondary (Disabled, 30, 60, 90 minutes) – Available on dual relay versions only

Passive Infrared:

- Dual element pyrometer and lens designed for reliable detection of a walking person.
- NOTE: When used with program start ballast, a 1-2 second delay from occupancy detection to lamp turn-on may be experienced. HBA recommends that you consult your fixture/ballast manufacturer for suitability with occupancy sensors.

Load Ratings (each relay):

- UNV models: 120VAC, 60Hz: 0-800W tungsten or standard ballast / 0-600W electronic ballast, 277VAC, 60Hz: 0-1200W ballast, 347VAC, 60Hz: 0-1500W ballast, ¼-HP motor load @ 120V, 1/6-HP @ 347V
- 208 models: 208/240VAC, 60Hz: 0-1200W ballast
- 480 models: 480VAC, 60Hz: 0-2400W ballast
- 24V models: HBA UVPP or MP Series Power pack required (sold separately)

Daylight Sensor Range: 30FC – 2500FC

Operating Environment:

- Standard Versions: Indoor Use Only; 32° – 149°F (0° – 65°C); Relative Humidity: 0 – 95% non-condensing.

PRECAUTIONS

- Read and understand all instructions before beginning installation.
- **NOTICE:** For installation by a licensed electrician in accordance with National and/or local Electrical Codes and the following instructions.
- Disconnect switch or a circuit breaker must be provided and marked as the disconnecting device.
- Disconnect switch / circuit breaker must be within reach of operator.
- **CAUTION: RISK OF ELECTRICAL SHOCK.** Turn power off at service panel before beginning installation. Never wire energized electrical components.
- **CAUTION: USE COPPER CONDUCTOR ONLY.**
- Confirm that device ratings are suitable for application prior to installation.
- Use only approved materials and components (i.e. wire nuts, electrical box, etc.) as appropriate for installation.
- **NOTICE:** Do not install if product appears to be damaged.
- If the equipment is used in a manner not specified by the manufacturer, the protection provided by the equipment may be impaired.

INSTALLATION OVERVIEW

The installation instructions contained in this document are provided as a guide for proper and reliable installation. The mounting location should be selected and prepared based on the lighting system application and facility layout requirements. All electrical wiring and mounting hardware (i.e. extension adapter (p/n WSPADAPTOR2), electrical mounting box, conduit, etc.) should be prepared with consideration of the requirements outlined in the wiring and mounting diagrams.

SURFACE MOUNT SENSOR INSTALLATION

1. Turn power off at the service panel before installing sensor.
2. Electrically connect the sensor to the lighting system per the applicable wiring diagram on page 5.
3. Attach sensor to fixture or electrical box using the (2) 8-32 x 1.25 mounting screws provided. Mounting holes should be 2.75" on center (See enclosed mounting diagram template). For indoor box mounting use a standard 3 1/2" octagon (RACO #110 or similar). Alternately, a 4" octagon box (RACO #125 or similar) may be used along with a 4" offset crossbar fixture strap. For outdoor applications use a 4" round water tight box (BELL #5361-1 or similar) Note: some water tight boxes use #10 screws. These will require the that the mounting holes in the sensor be enlarged to accommodate the #10 screws.
4. Adjust sensor operation by setting DIP switches as described on page 3 and 4.
5. Attach sensor lens to sensor module and rotate clockwise approximately five degrees to lock into place (See Fig. 1). Lens may be installed on sensor module rotated ninety degrees (See Figs. 3 and 4).
6. Turn power on and allow sensor 2 minutes minimum to stabilize.
7. Verify sensor is functioning by waving hand under lens and observing that the sensor's red light (located under the lens) flashes.
NOTE: Low Temp/Water Tight/ Indoor/Outdoor Surface Mount sensors feature a water tight gasket on the housing. Sensor must be installed flush onto a flat surface area to insure that a proper water tight seal is made between the sensor and the surface area.

END MOUNT SENSOR INSTALLATION

1. Turn power off at the service panel before installing sensor.
2. Insert the sensor's wires and threaded nipple into a 1/2" knockout on the fixture body or an electrical junction box.
3. Thread the sensor's wires through the lock-nut.
4. Verify that the sensor is positioned correctly (i.e. facing downward).
5. Screw lock-nut onto the sensor's threaded nipple and tighten.
6. Electrically connect the sensor to the lighting system per the applicable wiring diagram on page 5.
7. Adjust sensor operation by setting DIP switches as described on page 3 and 4.
8. Attach sensor lens to sensor module and rotate clockwise approximately five degrees to lock into place (See Fig. 1). Lens may be installed on sensor module rotated ninety degrees (See Figs. 3 and 4).
9. Turn power on and allow sensor 2 minutes minimum to stabilize.
10. Verify sensor is functioning by waving hand under lens and observing that the sensor's red light (located under the lens) flashes.
NOTE: Low Temp/Water Tight/ Indoor/ Outdoor End Mount sensors feature a water tight gasket that goes onto the chase nipple. Gasket must be installed onto the sensor's chase nipple to insure that a proper water tight seal is made between the sensor and the fixture.

END MOUNT SENSOR WITH EXTENDER INSTALLATION

For deep body fluorescent fixtures, where the height of the ballast cavity knockout is greater than or equal to 1.5", the extension adapter (p/n WSPADAPTOR2) should be used to position the sensor below the bottom of the reflector for full field of view coverage. *NOTE: Low Temp/Water Tight/ Indoor/ Outdoor End Mount sensors come with a water tight wire harness and chase nipple gasket. The wire harness feeds through the adapter and through the adapter's chase nipple. The chase nipple gasket that comes with the sensor should be placed on the adapter's chase nipple to insure that a proper water tight seal is made between the adapter and the fixture.*

LENS CONFIGURATION

Lens Model	Coverage	Mounting	Options
WSP	L360 360° Pattern	Blank High Mount LM Low Mount	Blank Indoor
	LA Aisle Pattern		
	L180 180° Pattern		
	LHA Half Aisle Pattern		

Example:

WSP-L360 WASP2 sensor lens, 360 coverage area

WSP-LA-LM WASP2 sensor lens, aisle coverage area, low mount,

SENSOR LENS INSTALLATION/ REMOVAL INSTRUCTIONS

1. Place lens assembly flush onto sensor module and rotate clockwise approximately five degrees to lock into place (see Fig. 1 & 2.)
2. To remove lens: Rotate lens assembly counter clockwise approximately five degrees and lift off.

SENSOR AND RANGE TESTING

Putting the sensor into test mode provides a means to confirm that the sensor's coverage pattern (see Figs. 5 and 6) is aligned properly in the lighted space as well as verifying the basic functionality of the sensor.

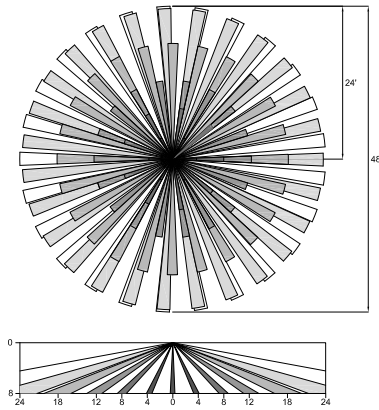

Fig 5. Sensor Lens Coverage and Detection Patterns When Mounted at 8ft with Low Mount Lens

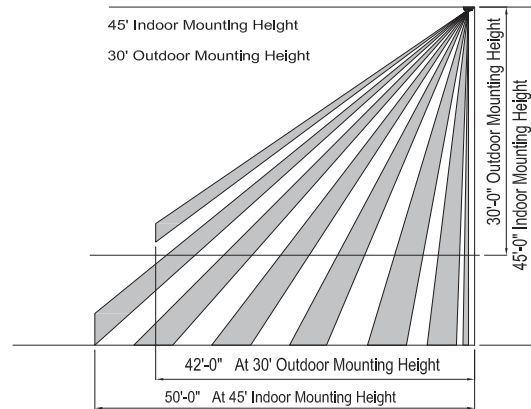

Fig 6. Sensor Lens Coverage and Detection Patterns When Mounted at 30ft and 45ft with Standard Lens

1. Remove lens from sensor module by rotating lens assembly counter clockwise approximately five degrees and lift off.
2. Set sensor's switch settings according to desired functionality.
3. Place sensor into Test Mode (8 seconds) by putting Switch 1 into the ON (Test) position. *NOTE: If switch is already in the ON position, switch it OFF then back to the ON position. The sensor's LED will blink in bursts of 4 to indicate that Test Mode is active. NOTE: When testing low voltage sensors, all sensors connected to power pack must be in Test Mode.*
4. Re-install sensor lens to sensor module and rotate clockwise approximately five degrees to lock into place (See Fig. 1). Lens may be installed on sensor module rotated ninety degrees (See Figs. 3 and 4).
5. Vacate the sensor detection pattern area. Remove obstructions (i.e. ladder or lift) from the sensor detection pattern area as necessary. Light(s) will turn off approximately 8 seconds after vacating detection pattern area.
6. Wait for at least 4 seconds, then re-enter sensor detection pattern area and observe that lights turn on.
7. Step out of sensor detection pattern area and observe that lights turn off approximately 8 seconds after vacating detection area. Note: In any two relay sensor, the primary lights will turn off after 8 seconds and the secondary lights after 10 seconds. If Smart Cycling is enabled, the Primary and Secondary ballast should change each cycle. *NOTE: If both Smart Cycling and Leave On Mode are enabled, the Primary and Secondary ballast will not cycle during Test Mode.*
8. Repeat steps 5 and 6 from different entry points on the detection pattern area as necessary to verify proper detection pattern area coverage.
9. If necessary, modify sensor detection pattern area by adjusting sensor and/or lens orientation.
10. Sensor will automatically exit Test Mode after 1 hour. Sensor detection will be indicated by a single blink of the LED. To manually exit Test Mode: remove lens assembly, set Switch 1 to the OFF (Normal) position and re-install lens.

SWITCH SETTINGS

SWITCH 1 – MODE: Controls the operational mode of the sensor. When placed in Test Mode (ON Position), the sensor will timeout after 8 seconds of no occupancy. The sensor's LED will blink in bursts of 4 to indicate that Test Mode is active. Note: In any two relay sensor, the primary lights will turn off after 8 seconds and the secondary lights after 10 seconds. If Smart Cycling is enabled, the Primary and Secondary ballast should change each cycle. *NOTE: If both Smart Cycling and Leave On Mode are enabled, the Primary and Secondary ballast will not cycle during Test Mode.* If switch is already in the ON position, turn the switch OFF then back to the ON position to enter Test Mode. Sensor will automatically exit Test Mode after 1 hour. Sensor detection will be indicated by a single blink of the LED. To manually exit Test Mode, return switch to the OFF position. Default: Normal (OFF Position).

SWITCH 2 – SMART CYCLING: Enables Smart Cycling feature on dual relay sensors. This feature extends lamp life by balancing the cumulative ON times for each relay. Each consecutive cycle automatically swaps the "Primary" and "Secondary" role of the relays. Default: Enabled (OFF Position).

SWITCH 3 – LEAVE ON: Allows for high/low operation using dual relay sensors. When enabled, the "Secondary" relay will remain ON during unoccupied periods. If Smart Cycling is enabled, the role of "Primary" and "Secondary" is automatically swapped between the two relays for each consecutive cycle. Default: Disabled (OFF Position).

SWITCH 4 – DAYLIGHT SENSOR SELECTION: Selects either the downward looking or upward looking daylight sensor. *NOTE: Upward looking daylight sensor is only available on end mount versions of the sensor. Default: Downward (OFF Position).*

72-00538, Rev. D

SWITCHES 5 & 6 – PRIMARY TIMER: Controls time interval to turn off light(s) controlled by Primary Timer after the lighted space becomes unoccupied. Available settings are 8, 4, 16, and 30 minutes. Default: 8 minutes (Switches 5 & 6 – OFF Position)

Primary	Switch 5	Switch 6
8 Mins	OFF	OFF
4 Mins	OFF	ON
16 Mins	ON	OFF
30 Mins	ON	ON

SWITCHES 7 & 8 – SECONDARY TIMER: Used on dual relay sensors only. Controls time interval to turn off light(s) controlled by Secondary Timer after the lighted space becomes unoccupied. Available settings are DISABLED (Secondary lights switch off with Primary), 30, 60, and 90 minutes. Default: DISABLED (Switches 7 & 8 – OFF Position).

Secondary	Switch 7	Switch 8
Disabled	OFF	OFF
30 Mins	OFF	ON
60 Mins	ON	OFF
90 Mins	ON	ON

SWITCHES 9, 10, 11 & 12 – DAYLIGHT SENSOR SET POINT LEVELS:

Enables or disables daylight sensor operation. When enabled, the sensor turns lights on in response to occupancy when light levels are below the daylight sensor set point – set by Switches 9-12. Daylight sensor setting should be set to a value that turns off artificial lighting when natural light levels reach the designed light levels at task. To determine this value, light level measurements should be taken when the natural light levels are at their highest peak (typically between 10am – 2pm). With artificial lighting on, measure the light level at the task area. When the measurement at task level is twice the design level, measure the light level at the sensor. *NOTE: light meter should be oriented in the same direction as the selected upward or downward looking daylight sensor. Configure switches 9-12 to the value closest to the meter's reading. Default: Disabled (Switches 9-12 – OFF Position).*

Sensor operation when daylight sensor is disabled:

- Single Output Sensor – Occupancy controlled.
- Dual Output Sensor – Output 1 & Output 2: Occupancy controlled. Smart Cycling and Leave On Mode function as normal.

Sensor operation when daylight sensor is enabled:

- Single Output Sensor - Occupancy controlled with daylighting override.
- Dual Output Sensor – Output 1: Occupancy controlled with daylighting override; Output 2: Occupancy controlled. *NOTE: If Smart Cycling is enabled, the daylighting override will stay with the 'Primary' relay which will switch back and forth between the output channels. If Smart Cycling is disabled, daylighting override will remain with Output 1. Daylighting override can be assigned to Output 2 by disabling Smart Cycling, enabling Leave On Mode and by setting the Secondary Timer to anything other than DISABLED.*

UPWARD LOOKING

Set Point Levels	Dead Band	Switch 9	Switch 10	Switch 11	Switch 12
Sensor Disabled	N/A	OFF	OFF	OFF	OFF
2500 FC	20%	OFF	OFF	OFF	ON
2000 FC	20%	OFF	OFF	ON	OFF
1800 FC	20%	OFF	OFF	ON	ON
1400 FC	20%	OFF	ON	OFF	OFF
1000 FC	20%	OFF	ON	OFF	ON
800 FC	20%	OFF	ON	ON	OFF
600 FC	20%	OFF	ON	ON	ON
400 FC	20%	ON	OFF	OFF	OFF
300 FC	20%	ON	OFF	OFF	ON
250 FC	20%	ON	OFF	ON	OFF
200 FC	20%	ON	OFF	ON	ON
150 FC	20%	ON	ON	OFF	OFF
100 FC	20%	ON	ON	OFF	ON
50 FC	20%	ON	ON	ON	OFF
30 FC	20%	ON	ON	ON	ON

DOWNWARD LOOKING

Set Point Levels	Dead Band	Switch 9	Switch 10	Switch 11	Switch 12
Sensor Disabled	N/A	OFF	OFF	OFF	OFF
100 FC	20%	OFF	OFF	OFF	ON
75 FC	20%	OFF	OFF	ON	OFF
50 FC	20%	OFF	OFF	ON	ON
25 FC	20%	OFF	ON	OFF	OFF
20 FC	20%	OFF	ON	OFF	ON
15 FC	20%	OFF	ON	ON	OFF
12.5 FC	20%	OFF	ON	ON	ON
10 FC	20%	ON	OFF	OFF	OFF
8 FC	20%	ON	OFF	OFF	ON
7 FC	20%	ON	OFF	ON	OFF
6 FC	20%	ON	OFF	ON	ON
5 FC	20%	ON	ON	OFF	OFF
4FC	25%	ON	ON	OFF	ON
3 FC	33%	ON	ON	ON	OFF
1 FC	50%	ON	ON	ON	ON

Note: Dead band is factory set. To prevent unwanted cycling, the light level at the sensor face must exceed the FC set point by the amount of dead band before the lights will turn off. Conversely, the light level must drop below the set point plus the dead band before the lights will turn on.

SWITCH SETTINGS FOR DISABLING ALL SENSOR FUNCTIONALITY

In order to disable all sensor functionality, set DIP switches to the following positions. Note: switch settings apply to all WASP2 models, including single relay versions that do not use switches 7 and 8 in normal operation. If sensor functionality does not need to be disabled, refer to switch settings guide above.

- Switch 2 – Smart Cycling: ON
- Switch 3 – Leave On: ON
- Switch 7 – Secondary Timer: ON
- Switch 8 – Secondary Timer: ON

72-00538, Rev. D

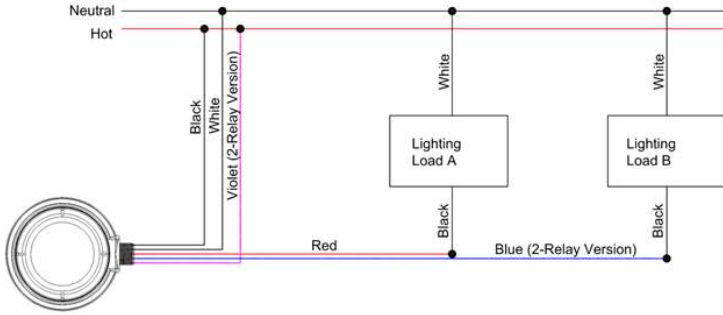

Wiring Diagram A – 120/277/347VAC Line voltage wiring diagram for single and dual relay sensors (Single Phase Only).

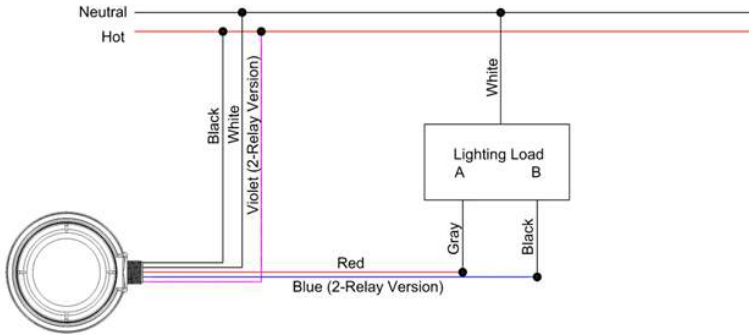

Wiring Diagram B – 120/277/347VAC Line voltage wiring diagram for connecting a dual relay sensor to a switching ballast.
Note: Disable Smart Cycling for this configuration.

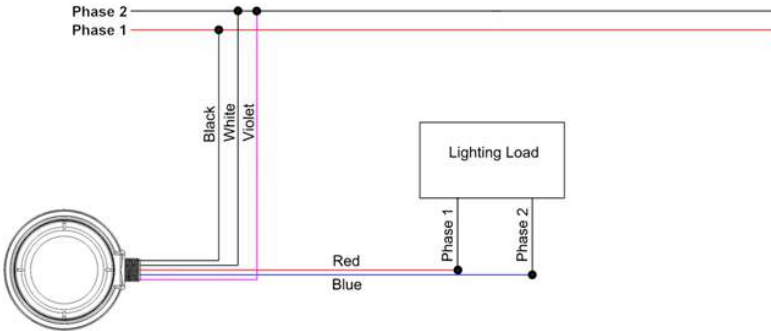

Wiring Diagram C – 208/240VAC & 480VAC Line voltage wiring diagram.

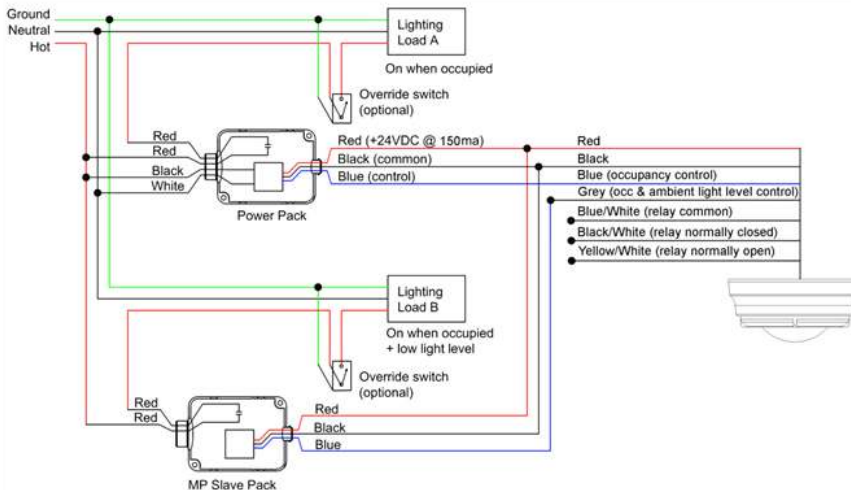

Wiring Diagram D – Low voltage sensor wiring diagram.

72-00538, Rev. D