

HDSP-521A/523A

14.22-mm (0.56-in.) Dual-Digit General-Purpose Seven-Segment Display

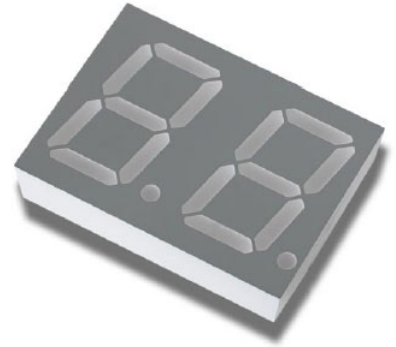

Description

The Broadcom® 14.22-mm (0.56-in.) LED dual-digit seven-segment displays use industry-standard size package and pinout. The device is available in either common anode or common cathode. These gray face displays are suitable for indoor use.

Devices

AllnGaP Deep Red	Description
HDSP-521A	Common Anode Right-Hand Decimal
HDSP-523A	Common Cathode Right-Hand Decimal

Features

- Industry-standard size
- Industry-standard pinout
14.22-mm (0.56-in.) DIP lead on 2.54 mm
- AllnGaP Deep Red
- Excellent appearance
Evenly lighted segments gray package gives optimum contrast ± 50 -ft. viewing angle
- Design flexibility
Common anode right-hand decimal point or common cathode right-hand decimal point

Applications

- Suitable for indoor use
- Not recommended for industrial applications, that is operating temperature requirements exceeding $+85^{\circ}\text{C}$ or below -40°C ¹
- Extreme temperature cycling not recommended

1. For additional details, contact your local Broadcom sales office or an authorized distributor.

Package Dimensions

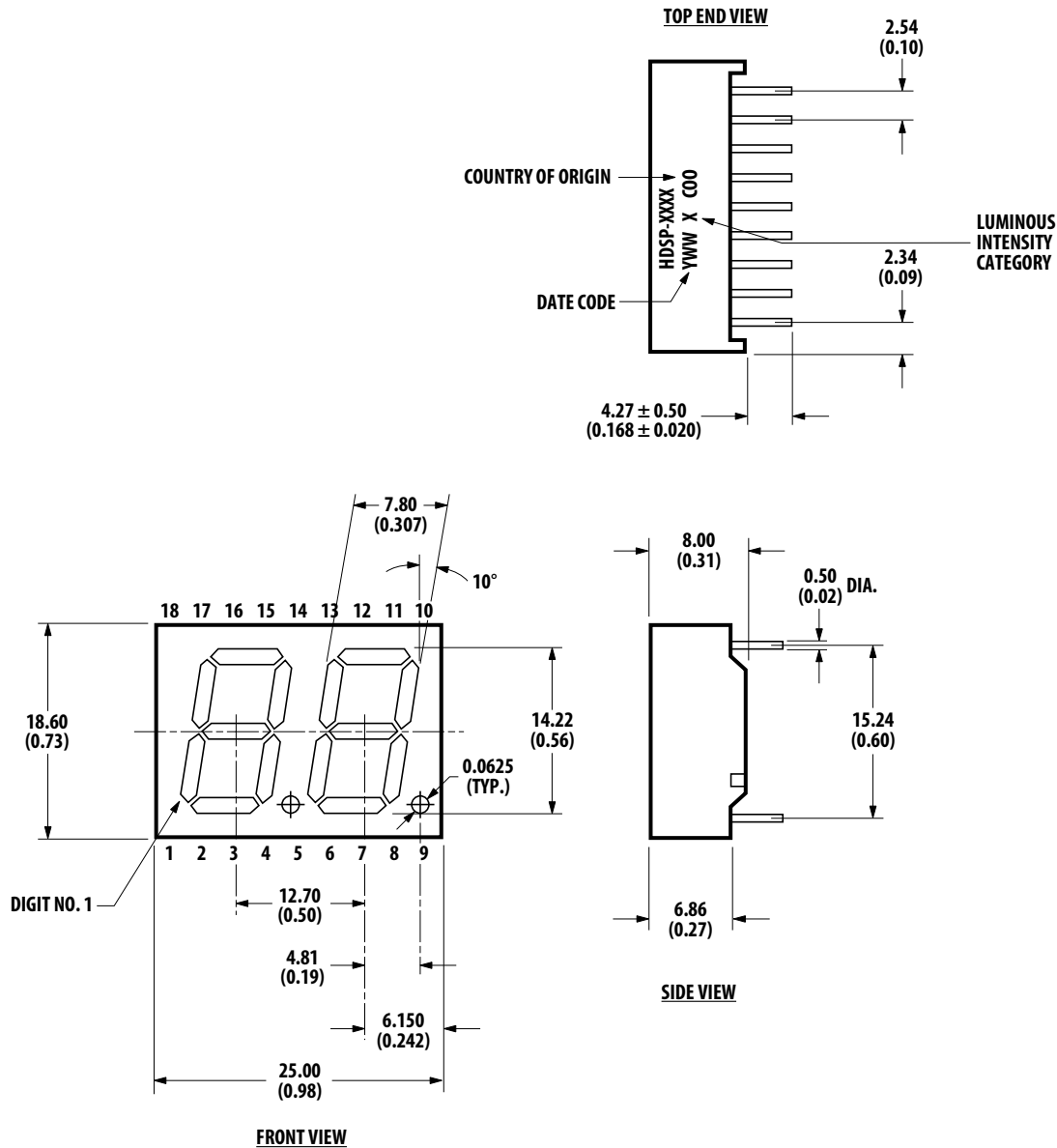

- Notes:**
1. ALL DIMENSIONS ARE IN MILLIMETERS (INCHES).
 2. TOLERANCE IS 0.25 mm (0.01 INCH) UNLESS OTHERWISE STATED.

Internal Circuit Diagram

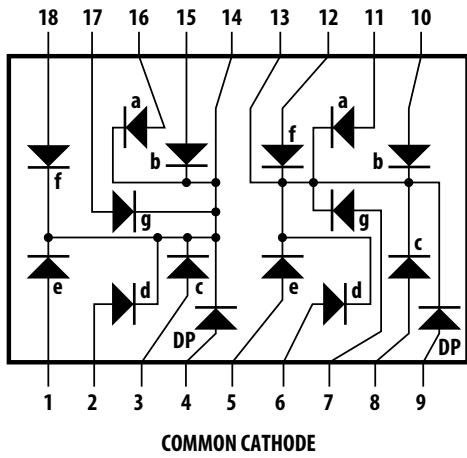
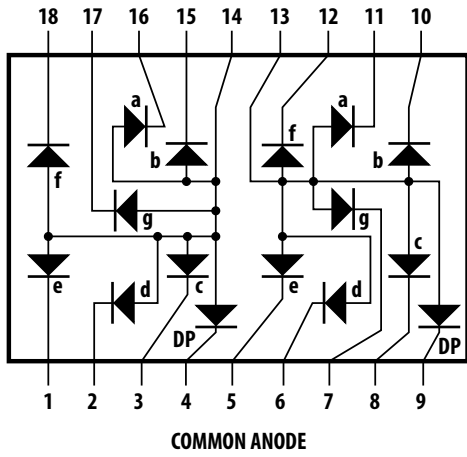

COMMON ANODE		COMMON CATHODE	
PIN	FUNCTION	PIN	FUNCTION
1	E CATHODE NO. 1	1	E ANODE NO. 1
2	D CATHODE NO. 1	2	D ANODE NO. 1
3	C CATHODE NO. 1	3	C ANODE NO. 1
4	DP CATHODE NO. 1	4	DP ANODE NO. 1
5	E CATHODE NO. 2	5	E ANODE NO. 2
6	D CATHODE NO. 2	6	D ANODE NO. 2
7	G CATHODE NO. 2	7	G ANODE NO. 2
8	C CATHODE NO. 2	8	C ANODE NO. 2
9	DP CATHODE NO. 2	9	DP ANODE NO. 2
10	B CATHODE NO. 2	10	B ANODE NO. 2
11	A CATHODE NO. 2	11	A ANODE NO. 2
12	F CATHODE NO. 2	12	F ANODE NO. 2
13	DIGIT NO. 2 ANODE	13	DIGIT NO. 2 CATHODE
14	DIGIT NO. 1 ANODE	14	DIGIT NO. 1 CATHODE
15	B CATHODE NO. 1	15	B ANODE NO. 1
16	A CATHODE NO. 1	16	A ANODE NO. 1
17	G CATHODE NO. 1	17	G ANODE NO. 1
18	F CATHODE NO. 1	18	F ANODE NO. 1

Absolute Maximum Ratings at $T_A = 25^\circ\text{C}$

Parameter	Deep Red HDSP-52xA	Units
Power Dissipation Segment	52	mW
Forward Current Segment	20 ^a	mA
Peak Forward Current per Segment (duty factor = 10%, frequency = 1 kHz)	60	mA
Operating Temperature Range	-40 to +85	°C
Storage Temperature Range	-40 to +85	°C
Reverse Voltage per Segment or DP	Not designed for reverse bias operation	
Wavesoldering Temperature for 3 seconds ^b (at 2 mm distance from the body)	250	°C

a. Derate linearly as shown in Figure 4.

b. Not recommended to be soldered more than twice. The minimum interval between solderings is 15 minutes. The total soldering time must not exceed 5 seconds.

Electrical/Optical Characteristics at $T_A = 25^\circ\text{C}$

Deep Red

Device	Parameter	Symbol	Min.	Typ.	Max.	Units	Test Conditions
HDSP-521A, HDSP-523A	Luminous Intensity/Segment (Average per Segment) ^{a, b, c}	I_V	3.201	3.66	—	mcd	$I_F = 5 \text{ mA}$
			—	6.500	—	mcd	$I_F = 10 \text{ mA}$
	Forward Voltage/Segment ^d	V_F	—	2.0	2.6	V	$I_F = 20 \text{ mA}$
	Peak Wavelength	λ_P	—	660	—	nm	
	Dominant Wavelength ^e	λ_d	—	640	—	nm	
Reverse Voltage/Segment or DP ^f	V_R	5	—	—	V	$I_R = 100 \mu\text{A}$	

a. The luminous intensity, I_V , is measured at the mechanical axis of the package.

b. The optical axis is closely aligned with the mechanical axis of the package.

c. Tolerance is $\pm 15\%$.

d. Forward voltage tolerance is $\pm 0.1\text{V}$.

e. The dominant wavelength, λ_d , is derived from the CIE Chromaticity Diagram and represents the perceived color of the device.

f. Indicates product final test condition. Long-term reverse bias is not recommended.

Intensity Bin Limits (mcd at 10 mA)

Bin Name	Deep Red	
	Min. ^a	Max. ^a
J	3.201	5.050
K	5.051	8.000
L	8.001	12.650

a. Tolerance for each bin limit is $\pm 15\%$.

AllnGaP Deep Red

Figure 1: Spectral Power Distribution

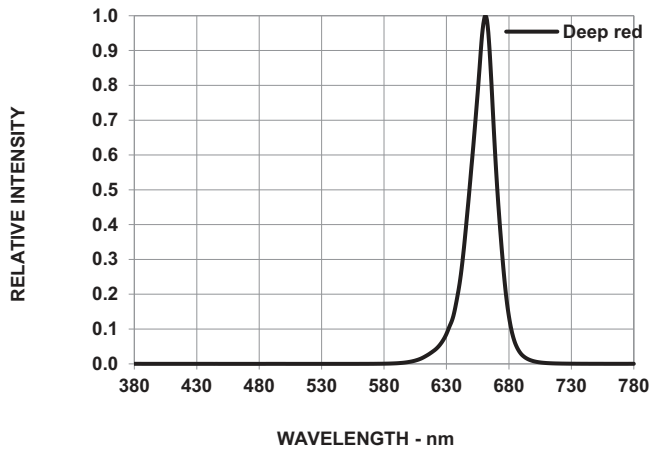

Figure 2: Forward Current vs. Forward Voltage

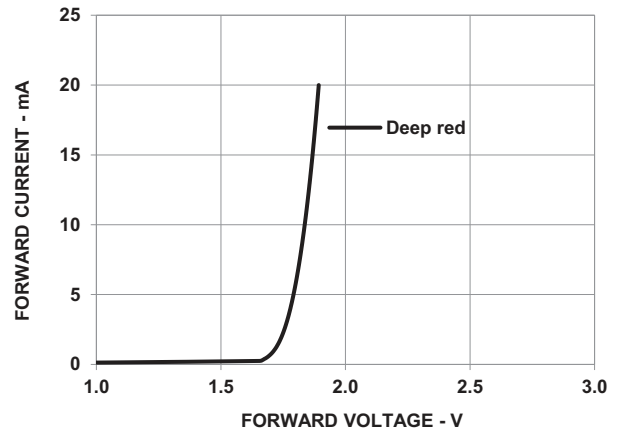

Figure 3: Relative Luminous Intensity vs. Forward Current

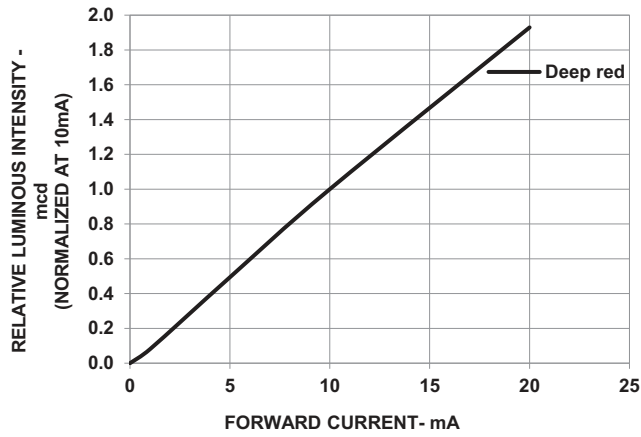
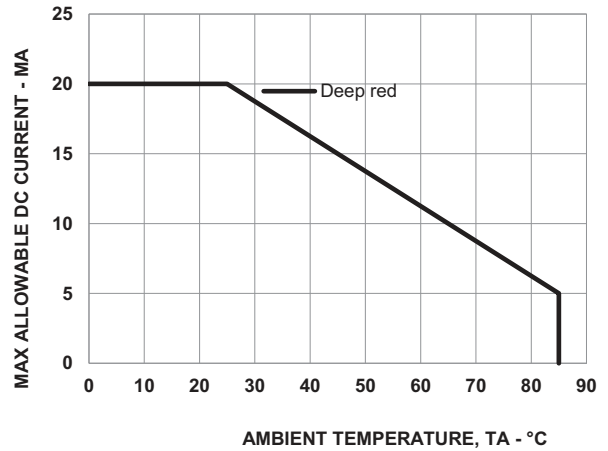

Figure 4: Maximum Forward Current vs. Ambient Temperature



Precautionary Notes

Soldering and Handling Precautions

- Set and maintain the wave soldering parameters according to the recommended temperature and dwell time. Perform daily checks on the profile to ensure that it conforms to the recommended conditions. Exceeding these conditions will over-stress the LEDs and cause premature failures.
- Use only bottom preheaters to reduce thermal stress experienced by the LEDs.
- Recalibrate the soldering profile before loading a new type of PCB. A PCB with a different size and design (component density) will have a different heat capacity and might cause a change in temperature experienced by the PCB if the same wave soldering setting is used
- Do not perform wave soldering more than once.
- Loosely fit any alignment fixture used during wave soldering and do not apply stress on the LEDs. Use a nonmetal material because it will absorb less heat during the wave soldering process.
- At elevated temperatures, the LEDs are more susceptible to mechanical stress. Allow the PCB to be sufficiently cooled to room temperature before handling. Do not apply stress to the LED when it is hot.
- Use wave soldering to solder the LED. Use hand soldering only for rework or touch up if unavoidable, but it must be strictly controlled to following conditions:
 - Soldering iron tip temperature = 315°C maximum.
 - Soldering duration = 2 seconds maximum.
 - Number of cycle = 1 only
 - Power of soldering iron = 50W maximum.
 - For ESD sensitive devices, apply proper ESD precautions at the soldering station. Use only ESD-safe soldering iron.
- Do not touch the LED package body with the soldering iron except for the soldering terminals because it may cause damage to the LED.
- Confirm beforehand whether the functionality and performance of the LED is affected by soldering with hand soldering.
- Keep the heat source at least 1.6 mm away from the LED body during soldering.
- Design an appropriate hole size to avoid problems during insertion.
- Do not use cleaning agents from the ketone family (acetone, methyl ethylketone, and so on) and from the chlorinated hydrocarbon family (methylene chloride, trichloroethylene, carbon tetrachloride, and so on) to

clean the LED displays. All of these solvents attack or dissolve the encapsulating epoxies used to form the package of plastic LED parts.

- For cleaning, wash with DI water only. The cleaning process should take place at room temperature only. Clear any water or moisture from the LED display immediately after washing.
- Use of *No clean* solder paste for soldering.

Figure 5: Recommended Wave Soldering Profile

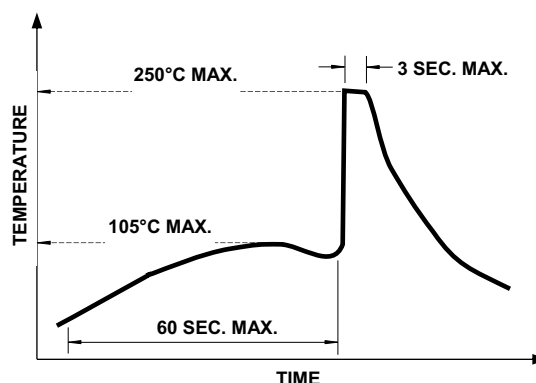

NOTE: Refers to measurements with thermocouple mounted at the bottom of the PCB.

Application Precautions

- The drive current of the LED must not exceed the maximum allowable limit across temperature as stated in the data sheet. Constant current driving is recommended to ensure consistent performance.
- The circuit design must cater to the entire range of forward voltage (V_F) of the LEDs to ensure the intended drive current can always be achieved.
- The LED exhibits slightly different characteristics at different drive currents, which may result in a larger variation of performance (such as intensity, wavelength, and forward voltage). Set the application current as close as possible to the test current to minimize these variations.
- The LED is not intended for reverse bias. Use other appropriate components for such purposes. When driving the LED in matrix form, ensure that the reverse bias voltage does not exceed the allowable limit of the LED.

- Avoid rapid changes in ambient temperature, especially in high-humidity environments, because they cause condensation on the LED.
- If the LED is intended to be used in a harsh or an outdoor environment, protect the LED against damages caused by rain, water, dust, oil, corrosive gases, external mechanical stresses, and so on.

Eye Safety Precautions

LEDs may pose optical hazards when in operation. Do not look directly at operating LEDs because it might be harmful to the eyes. For safety reasons, use appropriate shielding or personal protective equipment.

Broadcom, the pulse logo, Connecting everything, Avago Technologies, Avago, and the A logo are among the trademarks of Broadcom and/or its affiliates in the United States, certain other countries, and/or the EU.

Copyright © 2014–2021 Broadcom. All Rights Reserved.

The term “Broadcom” refers to Broadcom Inc. and/or its subsidiaries. For more information, please visit www.broadcom.com.

Broadcom reserves the right to make changes without further notice to any products or data herein to improve reliability, function, or design. Information furnished by Broadcom is believed to be accurate and reliable. However, Broadcom does not assume any liability arising out of the application or use of this information, nor the application or use of any product or circuit described herein, neither does it convey any license under its patent rights nor the rights of others.

