

ISOMETRIC
SEGMENT VIEW
SCALE 2:1

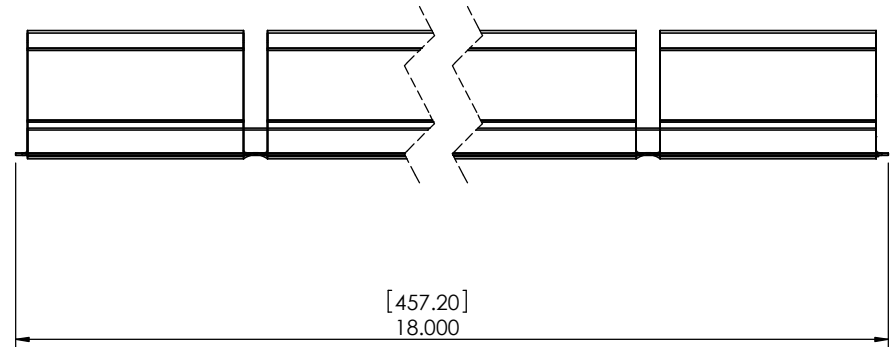
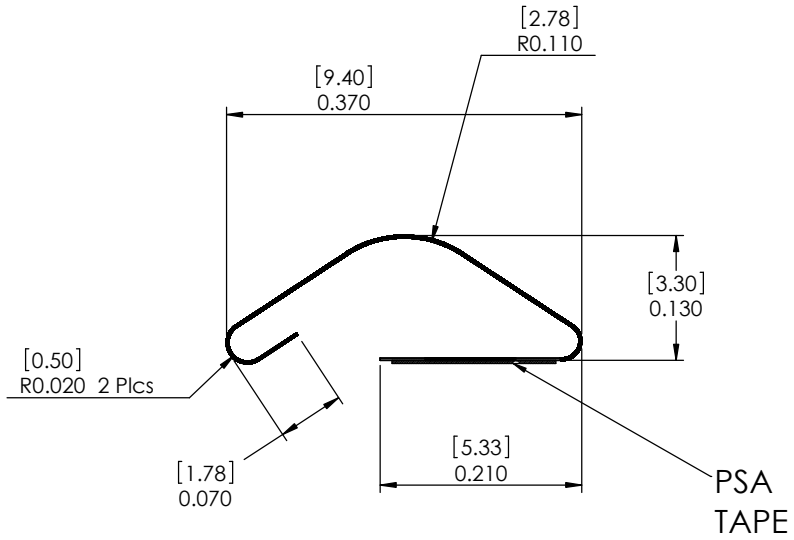
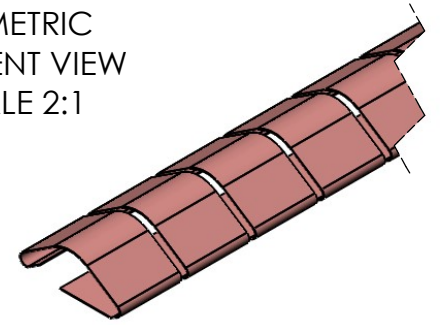

RoHS Compliant		DIMENSIONS ARE IN INCHES [MILLIMETERS] TOLERANCES: FRACTIONAL ± ANGULAR: MACH ± 3 Degrees TWO PLACE DECIMAL ± .015 [.381] THREE PLACE DECIMAL ± .010 [.254]	NAME	DATE	
THIRD ANGLE PROJECTION 			DRAWN	TNC	
DO NOT SCALE DRAWING		CHECKED			
PROPRIETARY AND CONFIDENTIAL THE INFORMATION CONTAINED IN THIS DRAWING IS THE SOLE PROPERTY OF ORBEL CORPORATION. ANY REPRODUCTION IN PART OR AS A WHOLE WITHOUT THE WRITTEN PERMISSION OF ORBEL CORPORATION IS PROHIBITED.		MFG APPR.			
		Q.A.			
		COMMENTS:			
		WEIGHT: 0.133oz. [3.783g]			
		SIZE DWG NO. A 26B02-BFA01800T		REV. 01	
		SCALE: 1:10	CAGE CODE: 57DU2		SHEET 1 OF 1

HOW TO ORDER FINGER-STOCK GASKETS

The chart below is an easy-to-use reference on how Orbel finger-stock gasket part numbers are created and used to order standard and custom gaskets. Custom configurations that fall outside of our standard gasket styles are also available.

Sample Part Number: 30B09-BFA024000T

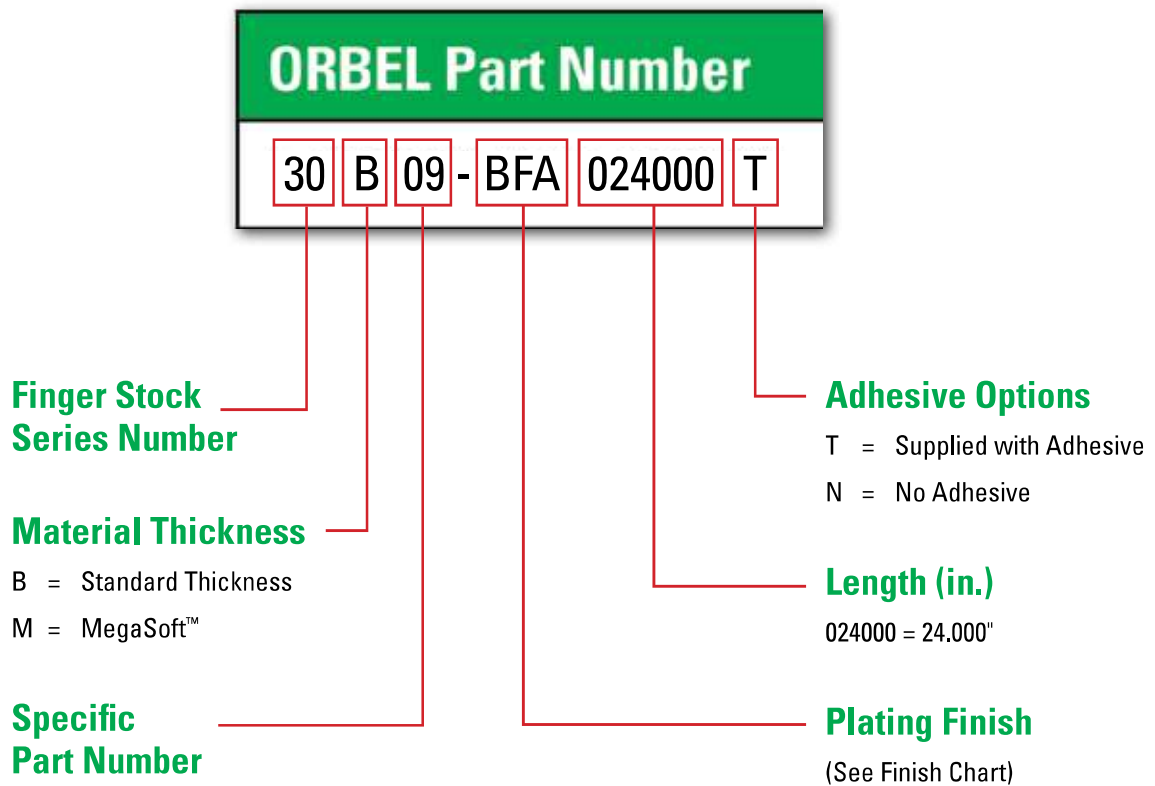

PLATING FINISHES			
Finish Type	Finish Code	Finish Type	Finish Code
SILVER	AGA	NICKEL, ELECTROLESS	NIP
GOLD .000050" MIN	AUA	TIN/LEAD 90/10, MATTE	PBA
GOLD .000050" MIN with NICKEL FLASH UNDERPLATE	AUK	TIN/LEAD 60/40, MATTE	PBB
BRIGHT FINISH, UNPLATED	BFA	TIN/LEAD 90/10, BRIGHT	PBC
BRIGHT FINISH, SOLDERABLE	BFS	TIN/LEAD 60/40, BRIGHT	PBD
CADMIUM + CLEAR CHROMATE	CDA	TIN, BRIGHT	SNA
CADMIUM + YELLOW CHROMATE	CDB	TIN, MATTE	SNB
NICKEL, BRIGHT	NIA	ZINC + CLEAR CHROMATE	ZNA
NICKEL, MATTE OR SULFAMATE NICKEL	NIB	ZINC + YELLOW CHROMATE	ZNB

All plating thicknesses are .0001" min. except where noted.