

© 2019 TE Connectivity. All Rights Reserved.

POS.	L	PART-NO.		
2	5.08	215300 -2		
3	7.62	-3		
4	10.16	-4		
5	12.70	-5		
6	15.24	-6		
7	17.78	-7		OBSOLETE
8	20.32	-8		
9	22.86	-9		OBSOLETE
10	25.40	1-	-0	
11	27.94	1-	-1	
12	30.48	1-	-2	
13	33.02	1-	-3	OBSOLETE
14	35.56	1-	-4	OBSOLETE
15	38.10	1-	-5	OBSOLETE
16	40.64	1-	-6	OBSOLETE
17	43.18	1-	-7	
18	45.72	1-	-8	
19	48.26	1-	-9	
20	50.80	2-	-0	
21	53.34	2-	-1	
22	55.88	2-	-2	
23	58.42	2-	-3	
24	60.96	2-	-4	OBSOLETE
25	63.50	2-	-5	
26	66.04	2-	-6	OBSOLETE
27	68.58	2-	-7	OBSOLETE
28	71.12	2-	-8	OBSOLETE
29	73.66	2-	-9	OBSOLETE
30	76.2	3-	-0	
31	78.74	3-	-1	OBSOLETE
32	81.28	3-	-2	
33	83.82	3-	-3	
34	86.36	3-	-4	OBSOLETE
35	88.90	3-	-5	
36	91.44	3-	-6	OBSOLETE

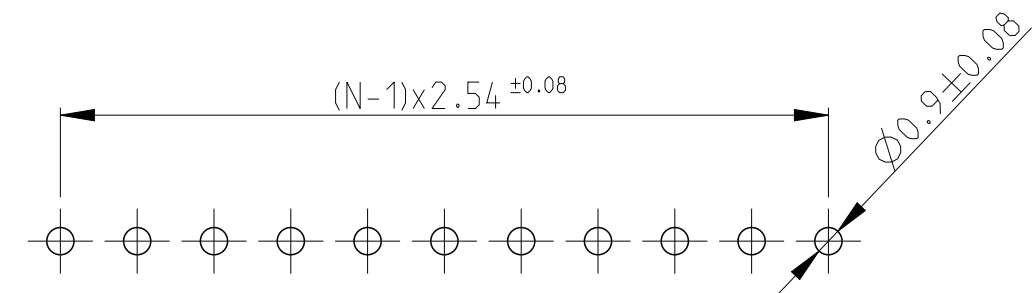
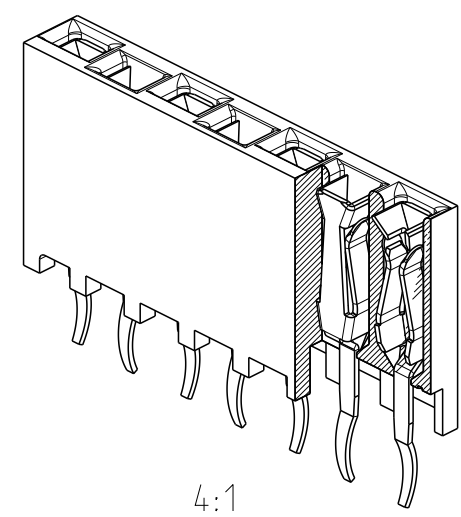
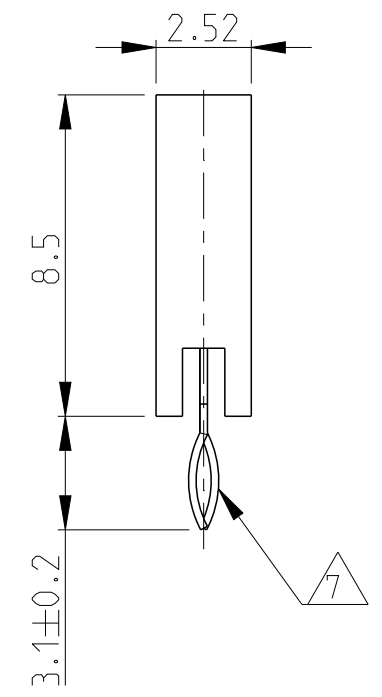
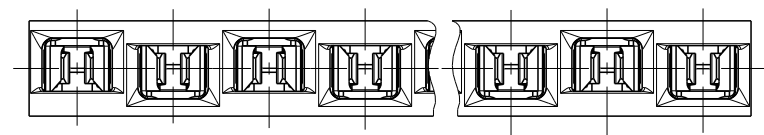
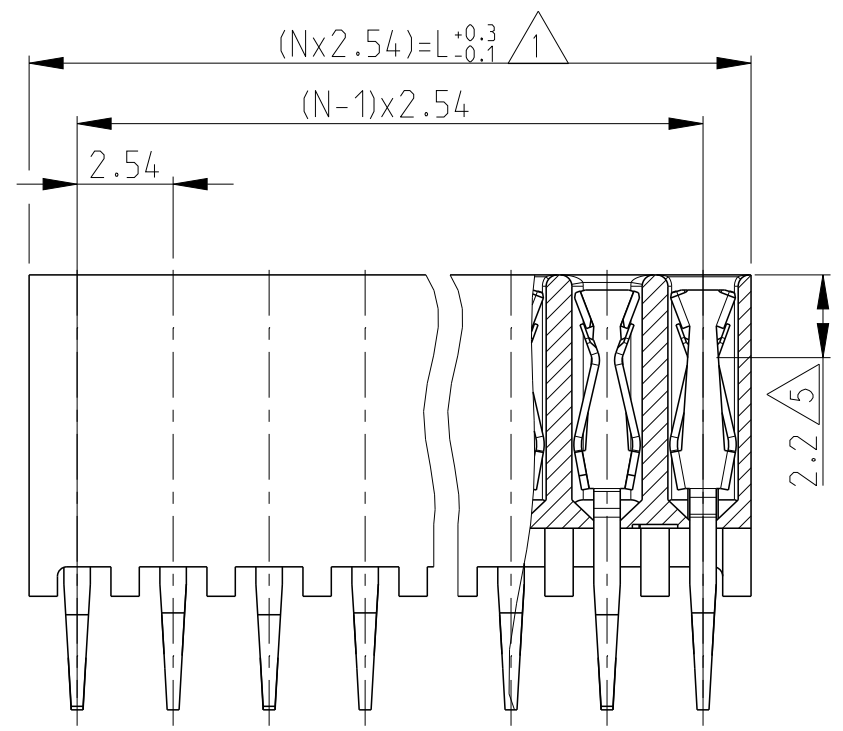

REVISIONS					
P	LTR	DESCRIPTION	DATE	DWN	APVD
	G	PLASTIC MATERIAL SUPPLIER CHANGE	18MAR2019	SS	PS
	H	PLASTIC MATERIAL COLOR CHANGE	19MAR2023	AJK	SPS

- NOTES:
- 1. TO DETERMINE DIMENSIONS TAKE N = NO. OF POS.  
FOR EXAMPLE: 10 POS.: N x 2.54 = 25.4 mm  
FOR ORDER NO. USE BASIC NO. + NO. OF POS.  
FOR EXAMPLE: 2 POS.= 215300-2 (SHORTEST VERSION)  
36 POS.= 3-215300-6 (LONGEST VERSION)
  - 2. HOUSING MATERIAL: PBT BLACK GLASSFILLED,  
UL 94V-0  
CONTACT MATERIAL: PHOSPHOR BRONZE.
  - 3. PLATING: 2.5 μm-4.0 μm TIN OVER MIN 0.5 μm NICKEL
  - 4. MATES WITH 0.63 SQUARE/ROUND MODU POSTS.
  - 5. CONTACT-POINT.
  - 6. RECOMMENDED P.C.BOARD-THICKNESS: 1.6mm.
  - 7. PC-BOARD RETENTION FEATURE.
  - 8. HV100 CONNECTOR PACKED IN ANTISTATIC BLISTER TRAY

THIS DRAWING IS A CONTROLLED DOCUMENT.		DWN L.V.D. HEYDEN 07SEP1986			
DIMENSIONS: mm		CHK W.SIMONS			
TOLERANCES UNLESS OTHERWISE SPECIFIED: ±0.15		APVD L.V.SQEST	NAME HV100 CONNECTOR ; VERTICAL; 8.5mm TOP ENTRY: SINGLE ROW; TIN		
0 PLC ± 1 PLC ± 2 PLC ± 3 PLC ± 4 PLC ± ANGLES ±		PRODUCT SPEC 108-19056	SIZE A3	CAGE CODE 00779	DRAWING NO C=215300
MATERIAL 2		FINISH 3	APPLICATION SPEC -	RESTRICTED TO	
CUSTOMER DRAWING			WEIGHT -	SCALE 5:1	SHEET 1 OF 1
			REV H		