

# ISO3086T Isolated 5-V RS-485 Transceiver With Integrated Transformer Driver

## 1 Features

- Meets or exceeds TIA/EIA-485-A
- Signaling rate up to 20 Mbps
- 1/8 unit load – up to 256 nodes on a bus
- Thermal shutdown protection
- Typical efficiency > 60% ( $I_{LOAD} = 100\text{ mA}$ ) - see [SLUU469](#)
- Low bus capacitance 7 pF (typical)
- 50-kV/ $\mu\text{s}$  typical transient immunity
- Fail-safe receiver for bus open, short, idle
- Logic inputs are 5 V tolerant
- Bus-pin ESD protection
  - 11-kV HBM between bus-pins and GND2
  - 6-kV HBM between bus-pins and GND1
- Safety and regulatory approvals
  - 4242  $V_{PK}$  basic insulation per DIN EN IEC 60747-17 (VDE 0884-17)
  - 2500  $V_{RMS}$  isolation for 1 minute per UL 1577
  - CSA component acceptance notice 5A, IEC 60950-1 and IEC 61010-1 standards

## 2 Applications

- Isolated RS-485/RS-422 Interfaces
- Factory automation
- Motor/motion control
- HVAC and building automation networks
- Networked security stations

## 3 Description

The ISO3086T is an isolated differential line transceiver with integrated oscillator outputs that provide the primary voltage for an isolation transformer. The device is a full-duplex differential line transceiver for RS-485 and RS-422 applications that can easily be configured for half-duplex operation by connecting pin 11 to pin 14, and pin 12 to pin 13.

These devices are ideal for long transmission lines since the ground loop is broken to allow for a much larger common-mode voltage range. The symmetrical isolation barrier of the device is tested to provide 4242  $V_{PK}$  of isolation for 1 minute per VDE between the bus-line transceiver and the logic-level interface.

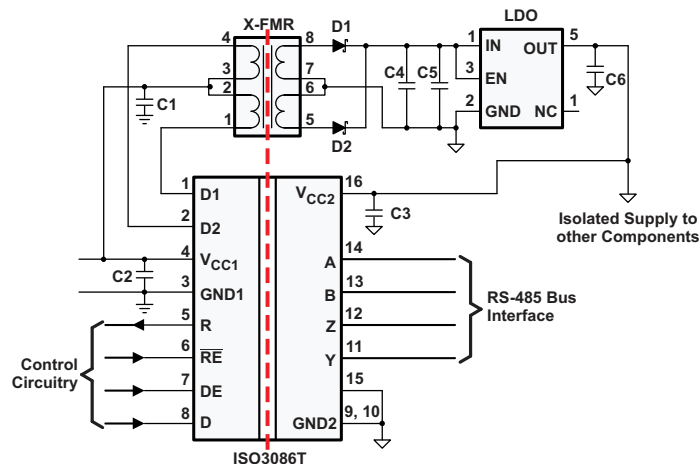
Any cabled I/O can be subjected to electrical noise transients from various sources. These noise transients can cause damage to the transceiver and/or near-by sensitive circuitry if they are of sufficient magnitude and duration. These isolated devices can significantly increase protection and reduce the risk of damage to expensive control circuits.

The ISO3086T is specified for use from  $-40^{\circ}\text{C}$  to  $85^{\circ}\text{C}$ .

### Device Information<sup>(1)</sup>

PART NUMBER	PACKAGE	BODY SIZE (NOM)
ISO3086T	SOIC (16)	10.30 mm × 7.50 mm

(1) For all available packages, see the orderable addendum at the end of the data sheet.



Typical Application Circuit



## Table of Contents

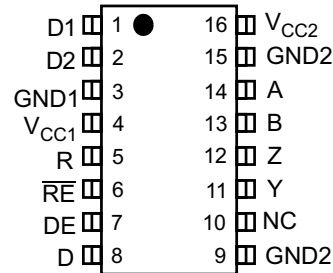
<b>1 Features</b> .....	1	<b>7 Parameter Measurement Information</b> .....	15
<b>2 Applications</b> .....	1	<b>8 Detailed Description</b> .....	19
<b>3 Description</b> .....	1	8.1 Overview.....	19
<b>4 Revision History</b> .....	2	8.2 Functional Block Diagram.....	19
<b>5 Pin Configuration and Functions</b> .....	3	8.3 Device Functional Modes.....	20
<b>6 Specifications</b> .....	4	<b>9 Application and Implementation</b> .....	23
6.1 Absolute Maximum Ratings.....	4	9.1 Application Information.....	23
6.2 ESD Ratings.....	4	9.2 Typical Application.....	23
6.3 Recommended Operating Conditions.....	4	<b>10 Power Supply Recommendations</b> .....	26
6.4 Thermal Information.....	6	<b>11 Layout</b> .....	27
6.5 Power Ratings.....	6	11.1 Layout Guidelines.....	27
6.6 Insulation Specifications.....	6	11.2 Layout Example.....	28
6.7 Safety-Related Certifications.....	7	<b>12 Device and Documentation Support</b> .....	29
6.8 Safety Limiting Values.....	7	12.1 Documentation Support.....	29
6.9 Electrical Characteristics: Driver.....	8	12.2 Receiving Notification of Documentation Updates.....	29
6.10 Electrical Characteristics: Receiver.....	8	12.3 Support Resources.....	29
6.11 Transformer Driver Characteristics.....	9	12.4 Trademarks.....	29
6.12 Supply Current.....	10	12.5 Electrostatic Discharge Caution.....	29
6.13 Switching Characteristics: Driver.....	11	12.6 Glossary.....	29
6.14 Switching Characteristics: Receiver.....	11	<b>13 Mechanical, Packaging, and Orderable Information</b> .....	29
6.15 Insulation Characteristics Curves.....	11		
6.16 Typical Characteristics.....	12		

## 4 Revision History

NOTE: Page numbers for previous revisions may differ from page numbers in the current version.

<b>Changes from Revision D (October 2015) to Revision E (August 2023)</b>	<b>Page</b>
• Updated the numbering format for tables, figures, and cross-references throughout the document.....	1
• Updated Thermal Characteristics, Safety Limiting Values, and Thermal Derating Curves to provide more accurate system-level thermal calculations.....	6
• Updated electrical and switching characteristics to match device performance.....	8
<b>Changes from Revision C (July 2011) to Revision D (October 2015)</b>	<b>Page</b>
• Added Feature Item "Meets or Exceeds TIA/EIA-485".....	1
• VDE standard changed to DIN V VDE V 0884-10 (VDE V 0884-10):2006-12 .....	1
• Added <i>Pin Configuration and Functions</i> section, <i>ESD Ratings</i> table, <i>Feature Description</i> section, <i>Device Functional Modes</i> , <i>Application and Implementation</i> section, <i>Power Supply Recommendations</i> section, <i>Layout</i> section, <i>Device and Documentation Support</i> section, and <i>Mechanical, Packaging, and Orderable Information</i> section .....	1
<b>Changes from Revision * (January 2011) to Revision A (March 2011)</b>	<b>Page</b>
• Changed the Features and Description.....	1
• Changed the data sheet From: Preview To: Production.....	1
• Added <a href="#">Figure 9-2</a> Typical Application Circuit.....	3

## 5 Pin Configuration and Functions



**Figure 5-1. DW Package 16-Pin SOIC Top View**

**Table 5-1. Pin Functions**

PIN		I/O	DESCRIPTION
NAME	NO.		
A	14	I	Non-inverting Receiver Input
B	13	I	Inverting Receiver Input
D1	1	O	Transformer Driver Terminal 1, Open Drain Output
D2	2	O	Transformer Driver Terminal 2, Open Drain Output
D	8	I	Driver Input
DE	7	I	Driver Enable Input
GND1	3	—	Logic-side Ground
GND2	9, 15	—	Bus-side Ground. Both pins are internally connected.
NC	10	—	No Connect. This pin is not connected to any internal circuitry.
R	5	O	Receiver Output
RE	6	I	Receiver Enable Input. This pin has complementary logic.
V <sub>CC1</sub>	4	—	Logic-side Power Supply
V <sub>CC2</sub>	16	—	Bus-side Power Supply
Y	11	O	Non-inverting Driver Output
Z	12	O	Inverting Driver Output

## 6 Specifications

### 6.1 Absolute Maximum Ratings

Over operating free-air temperature range (unless otherwise noted)<sup>(1)</sup>

		MIN	MAX	UNIT
$V_{CC}$ <sup>(2)</sup>	Supply voltage, $V_{CC1}$ , $V_{CC2}$	-0.3	6	V
$V_A$ , $V_B$ , $V_Y$ , $V_Z$	Voltage at any bus I/O terminal (A,B,Y,Z)	-9	14	V
$V_{D1}$ , $V_{D2}$	Voltage at D1, D2		14	V
$V_{(TRANS)}$	Voltage input, transient pulse, A, B, Y, and Z (through 100 $\Omega$ , see Figure 27)	-50	50	V
$V_I$	Voltage input at any D, DE or $\overline{RE}$ terminal	-0.5	6	V
$I_O$	Receiver output current	-10	10	mA
$I_{D1}$ , $I_{D2}$	Transformer Driver Output Current		450	mA
$T_J$	Junction temperature		150	$^{\circ}\text{C}$
$T_{STG}$	Storage temperature	-65	150	$^{\circ}\text{C}$

- (1) Stresses beyond those listed under *Absolute Maximum Ratings* may cause permanent damage to the device. These are stress ratings only, which do not imply functional operation of the device at these or any other conditions beyond those indicated under *Recommended Operating Conditions*. Exposure to absolute-maximum-rated conditions for extended periods may affect device reliability.
- (2) All voltage values except differential I/O bus voltages are with respect to network ground terminal and are peak voltage values.

### 6.2 ESD Ratings

			VALUE	UNIT
$V_{(ESD)}$	Human body model (HBM), per ANSI/ESDA/JEDEC JS-001 <sup>(1)</sup>	Bus pins and GND1	$\pm 6000$	V
$V_{(ESD)}$		Bus pins and GND2	$\pm 11000$	V
$V_{(ESD)}$		All pins	$\pm 4000$	V
$V_{(ESD)}$	Charged device model (CDM), per JEDEC specification JESD22-C101, all pins <sup>(2)</sup>		$\pm 1500$	V
$V_{(ESD)}$	Machine model (MM), ANSI/ESDS5.2-1996		$\pm 200$	V

- (1) JEDEC document JEP155 states that 500-V HBM allows safe manufacturing with a standard ESD control process.
- (2) JEDEC document JEP157 states that 250-V CDM allows safe manufacturing with a standard ESD control process.

### 6.3 Recommended Operating Conditions

		MIN	TYP	MAX	UNIT
$V_{CC1}$	Logic-side supply voltage - 3.3V operation	3	3.3	3.6	V
$V_{CC1}$	Logic-side supply voltage - 5 V operation	4.5	5	5.5	V
$V_{CC2}$	Bus-side supply voltage	4.5	5	5.5	V
$V_{IC}$	Voltage at any bus terminal (separately or common-mode)	-7		12	V
$V_{IH}$	High-level input voltage ( $\overline{RE}$ inputs)	2		$V_{CC1}$	V
$V_{IH}$	High-level input voltage (D, DE inputs)	$0.7 \cdot V_{CC}$			V
$V_{IL}$	Low-level input voltage ( $\overline{RE}$ inputs)	0		0.8	V
$V_{IL}$	Low-level input voltage (D, DE inputs)	0		$0.3 \cdot V_{CC}$	V
$V_{ID}$	Differential input voltage, A with respect to B	-12		12	V
$V_{ID}$	Differential input voltage, Dynamic	See Figure 16			V
$R_L$	Differential load resistance	54	60		$\Omega$
$I_O$	Output current, Driver	-60		60	mA

		MIN	TYP	MAX	UNIT
$I_O$	Output current, Receiver	-8		8	mA
$T_A$	Operating ambient temperature	-40		85	°C
$1/t_{UI}$	Signaling Rate			20	Mbps

## 6.4 Thermal Information

THERMAL METRIC <sup>(1)</sup>		ISO308x	UNIT
		DW (SOIC)	
		16 PINS	
$R_{\theta JA}$	Junction-to-ambient thermal resistance	80.5	°C/W
$R_{\theta JC(top)}$	Junction-to-case (top) thermal resistance	43.8	°C/W
$R_{\theta JB}$	Junction-to-board thermal resistance	49.7	°C/W
$\Psi_{JT}$	Junction-to-top characterization parameter	13.8	°C/W
$\Psi_{JB}$	Junction-to-board characterization parameter	41.4	°C/W
$R_{\theta JC(bot)}$	Junction-to-case (bottom) thermal resistance	—	°C/W

(1) For more information about traditional and new thermal metrics, see the [Semiconductor and IC Package Thermal Metrics application report](#).

## 6.5 Power Ratings

PARAMETER	TEST CONDITIONS	MIN	TYP	MAX	UNIT
$P_D$	Maximum power dissipation (both sides)			490	mW

$V_{CC1} = V_{CC2} = 5.5V$ ,  $T_J = 150^\circ C$ ,  $R_L = 54\Omega$ ,  $C_L = 50pF$  (Driver),  $C_L = 15pF$  (Receiver), Input a 10 MHz 50% duty cycle square wave to Driver and Receiver

## 6.6 Insulation Specifications

PARAMETER		TEST CONDITIONS	VALUE DW-16	UNIT
CLR	External clearance <sup>(1)</sup>	Shortest terminal-to-terminal distance through air	8	mm
CPG	External creepage <sup>(1)</sup>	Shortest terminal-to-terminal distance across the package surface	8	mm
DTI	Distance through the insulation	Minimum internal gap (internal clearance)	8	um
CTI	Comparative tracking index	DIN EN 60112 (VDE 0303-11); IEC 60112	>400	V
	Material group	According to IEC 60664-1	II	
	Overvoltage category per IEC 60664-1	Rated mains voltage $\leq 150 V_{RMS}$	I-IV	
		Rated mains voltage $\leq 300 V_{RMS}$	I-III	
<b>DIN EN IEC 60747-17 (VDE 0884-17) <sup>(2)</sup></b>				
$V_{IORM}$	Maximum repetitive peak isolation voltage	AC voltage (bipolar)	566	$V_{PK}$
$V_{IOTM}$	Maximum transient isolation voltage	$V_{TEST} = V_{IOTM}$ , $t = 60$ s (qualification); $V_{TEST} = 1.2 \times V_{IOTM}$ , $t = 1$ s (100% production)	4242	$V_{PK}$
$q_{pd}$	Apparent charge <sup>(3)</sup>	Method b; At routine test (100% production) $V_{ini} = 1.2 \times V_{IOTM}$ , $t_{ini} = 1$ s; $V_{pd(m)} = 1.5 \times V_{IORM}$ , $t_m = 1$ s	$\leq 5$	pC
$C_{IO}$	Barrier capacitance, input to output <sup>(4)</sup>	$V_{IO} = 0.4 \times \sin(2\pi ft)$ , $f = 1$ MHz	2	pF
$C_I$	Input capacitance to ground	$V_I = V_{CC}/2 + 0.4 \times \sin(2\pi ft)$ , $f = 1$ MHz, $V_{CC} = 5$ V	2	pF
$R_{IO}$	Isolation resistance <sup>(4)</sup>	$V_{IO} = 500$ V, $T_A = 25^\circ C$	$>10^{12}$	$\Omega$
		$V_{IO} = 500$ V, $T_S = 150^\circ C$	$>10^{12}$	
	Pollution degree		2	
	Climatic category		40/085/21	
<b>UL 1577</b>				

PARAMETER		TEST CONDITIONS	VALUE	UNIT
			DW-16	
$V_{ISO}$	Maximum withstanding isolation voltage	$V_{TEST} = V_{ISO}$ , $t = 60$ s (qualification), $V_{TEST} = 1.2 \times V_{ISO}$ , $t = 1$ s (100% production)	2500	$V_{RMS}$

- (1) Creepage and clearance requirements should be applied according to the specific equipment isolation standards of an application. Care should be taken to maintain the creepage and clearance distance of a board design to ensure that the mounting pads of the isolator on the printed-circuit board do not reduce this distance. Creepage and clearance on a printed-circuit board become equal in certain cases. Techniques such as inserting grooves and/or ribs on a printed-circuit board are used to help increase these specifications.
- (2) This coupler is suitable for *basic electrical insulation* only within the safety ratings. Compliance with the safety ratings shall be ensured by means of suitable protective circuits.
- (3) Apparent charge is electrical discharge caused by a partial discharge (pd).
- (4) All pins on each side of the barrier tied together creating a two-terminal device.

### 6.7 Safety-Related Certifications

VDE	CSA	UL
Certified according to DIN EN IEC 60747-17 (VDE 0884-17)	Certified according to IEC 60950-1 and IEC 61010-1	Approved under UL 1577 Component Recognition Program
Basic insulation Maximum Transient Isolation Voltage, 4242 $V_{PK}$ Maximum Surge Isolation Voltage, 4000 $V_{PK}$ Maximum Repetitive Peak Isolation Voltage, 566 $V_{PK}$	3000 $V_{RMS}$ Isolation Rating; Reinforced insulation per CSA 61010-1 and IEC 61010-1 150 $V_{RMS}$ working voltage; Basic insulation per CSA 61010-1 and IEC 61010-1 600 $V_{RMS}$ working voltage; Basic insulation per CSA 60950-1 and IEC 60950-1 760 $V_{RMS}$ working voltage	Single protection, 2500 $V_{RMS}$
Certificate number: 40047657	Master contract number: 220991	File number: E181974

### 6.8 Safety Limiting Values

Safety limiting<sup>(1)</sup> intends to minimize potential damage to the isolation barrier upon failure of input or output circuitry.

PARAMETER		TEST CONDITIONS	MIN	TYP	MAX	UNIT
<b>DW-16 PACKAGE</b>						
$I_S$	Safety input, output, or supply current	$R_{\theta JA} = 80.5^\circ\text{C/W}$ , $V_I = 5.5$ V, $T_J = 150^\circ\text{C}$ , $T_A = 25^\circ\text{C}$			282	mA
$T_S$	Maximum safety temperature				150	$^\circ\text{C}$

- (1) The maximum safety temperature,  $T_S$ , has the same value as the maximum junction temperature,  $T_J$ , specified for the device. The  $I_S$  and  $P_S$  parameters represent the safety current and safety power respectively. The maximum limits of  $I_S$  and  $P_S$  should not be exceeded. These limits vary with the ambient temperature,  $T_A$ .  
The junction-to-air thermal resistance,  $R_{\theta JA}$ , in the table is that of a device installed on a high-K test board for leaded surface-mount packages. Use these equations to calculate the value for each parameter:  
 $T_J = T_A + R_{\theta JA} \times P$ , where P is the power dissipated in the device.  
 $T_{J(max)} = T_S = T_A + R_{\theta JA} \times P_S$ , where  $T_{J(max)}$  is the maximum allowed junction temperature.  
 $P_S = I_S \times V_I$ , where  $V_I$  is the maximum input voltage.

## 6.9 Electrical Characteristics: Driver

All typical specs are at  $V_{CC1}=3.3V$ ,  $V_{CC2}=5V$ ,  $T_A=27^\circ C$ , (Min/Max specs are over recommended operating conditions unless otherwise noted)

PARAMETER		TEST CONDITIONS	MIN	TYP	MAX	UNIT
$ V_{OD} $	Driver differential-output voltage magnitude	$I_O = 0$ mA, no load	3	4.3	$V_{CC2}$	V
		$R_L = 54 \Omega$ , See Figure 17	1.5	2.3		V
		$R_L = 100 \Omega$ (RS-422), See Figure 17	2	2.3		V
		$V_{test}$ from $-7$ V to $+12$ V, See Figure 18	1.5			V
$\Delta V_{OD} $	Change in differential output voltage between two states	See Figure 17 and Figure 18	-200		200	mV
$V_{OC(SS)}$	Common-mode output voltage	See Figure 19	1	2.6	3	V
$\Delta V_{OC(SS)}$	change in steady-state common-mode output voltage between two states		-100		100	mV
$V_{OC(PP)}$	Peak-to-peak common-mode output voltage			0.5		V
$I_I$	Input current	D, DE, VI at 0 V or $V_{CC1}$	-10		10	$\mu A$
$I_{OZ}$	High-impedance state output current	$V_Y$ or $V_Z = 12$ V, $V_{CC2} = 0$ V or 5 V, DE = 0 V, Other input at 0 V			1	$\mu A$
$I_{OZ}$	High-impedance state output current	$V_Y$ or $V_Z = -7$ V, $V_{CC2} = 0$ V or 5 V, DE = 0 V, Other input at 0 V	-1			$\mu A$
$I_{OS}$	Short-circuit output current	$V_A$ or $V_B$ at $-7$ V, Other input at 0 V	-200		200	mA
$I_{OS}$	Short-circuit output current	$V_A$ or $V_B$ at 12 V, Other input at 0 V	-200		200	mA
CMTI	Common-mode transient immunity	$V_I = V_{CC}$ or 0 V, See Figure 14 and Figure 15	25	50		kV/ $\mu s$

## 6.10 Electrical Characteristics: Receiver

All typical specs are at  $V_{CC1}=3.3V$ ,  $V_{CC2}=5V$ ,  $T_A=27^\circ C$ , (Min/Max specs are over recommended operating conditions unless otherwise noted)

PARAMETER		TEST CONDITIONS	MIN	TYP	MAX	UNIT
$V_{IT+}$	Positive-going input threshold voltage	$I_O = -8$ mA		-85	-10	mV
$V_{IT-}$	Negative-going input threshold voltage	$I_O = 8$ mA	-200	-115		mV
$V_{hys}$	Input hysteresis ( $V_{IT+} - V_{IT-}$ )			30		mV
$V_{OH}$	High-level output voltage	$V_{ID} = 200$ mV, $I_O = -8$ mA, 3.3 V $V_{CC1}$	$V_{CC1} - 0.4$	3.1		V
	High-level output voltage	$V_{ID} = 200$ mV, $I_O = -8$ mA, 5 V $V_{CC1}$	4	4.8		V
$V_{OL}$	Low-level output voltage	$V_{ID} = -200$ mV, $I_O = 8$ mA, 3.3 V $V_{CC1}$		0.15	0.4	V
	Low-level output voltage	$V_{ID} = -200$ mV, $I_O = 8$ mA, 5 V $V_{CC1}$		0.15	0.4	V
$I_{OZ}$	Output high-impedance current on the R pin	$V_I = -7$ to 12 V, Other input = 0 V	-1		1	$\mu A$
$I_I$	Bus input current	$V_A$ or $V_B = 12$ V, Other input at 0 V		0.04	0.1	mA
		$V_A$ or $V_B = 12$ V, $V_{CC} = 0$ , Other input at 0 V		0.06	0.13	mA
		$V_A$ or $V_B = -7$ V, Other input at 0 V	-0.1	-0.04		mA
		$V_A$ or $V_B = -7$ V, $V_{CC} = 0$ , Other input at 0 V	-0.05	-0.03		mA
$I_{IH}$	High-level input current, $\overline{RE}$	$V_{IH} = 2$ V	-10		10	$\mu A$
$I_{IL}$	Low-level input current, $\overline{RE}$	$V_{IL} = 0.8$ V	-10		10	$\mu A$



All typical specs are at  $V_{CC1}=3.3V$ ,  $V_{CC2}=5V$ ,  $T_A=27^{\circ}C$ , (Min/Max specs are over recommended operating conditions unless otherwise noted)

PARAMETER		TEST CONDITIONS	MIN	TYP	MAX	UNIT
$R_{ID}$	Differential input resistance	A, B	96			kohm
$C_{ID}$	Differential input capacitance	$V_I = 0.4 \sin(4E6\pi t) + 0.5 V$		7		pF

## 6.11 Transformer Driver Characteristics

PARAMETER		TEST CONDITIONS	MIN	TYP	MAX	UNIT
$f_{OSC}$	Oscillator frequency	$V_{CC1} = 5 V \pm 10\%$ , D1 and D2 connected to transformer	350	450	610	kHz
$f_{OSC}$	Oscillator frequency	$V_{CC1} = 3.3 V \pm 10\%$ , D1 and D2 connected to transformer	300	400	550	kHz
$R_{ON}$	Switch on resistance	D1 and D2 connected to 50 $\Omega$ pullup resistors		1	2.5	ohm
$t_{r\_D}$	D1, D2 output rise time	$V_{CC1} = 5 V \pm 10\%$ , See Figure 28, D1 and D2 connected to 50- $\Omega$ pullup resistors		80		ns
$t_{r\_D}$	D1, D2 output rise time	$V_{CC1} = 3.3 V \pm 10\%$ , See Figure 28, D1 and D2 connected to 50- $\Omega$ pullup resistors		70		ns
$t_{f\_D}$	D1, D2 output fall time	$V_{CC1} = 5 V \pm 10\%$ , See Figure 28, D1 and D2 connected to 50- $\Omega$ pullup resistors		55		ns
$t_{f\_D}$	D1, D2 output fall time	$V_{CC1} = 3.3 V \pm 10\%$ , See Figure 28, D1 and D2 connected to 50- $\Omega$ pullup resistors		80		ns
$f_{St}$	Startup frequency	$V_{CC1} = 2.4 V$ , D1 and D2 connected to transformer		350		kHz
$t_{BBM}$	Break before make time delay	$V_{CC1} = 5 V \pm 10\%$ , See Figure 28, D1 and D2 connected to 50- $\Omega$ pullup resistors		38		ns
$t_{BBM}$	Break before make time delay	$V_{CC1} = 3.3 V \pm 10\%$ , See Figure 28, D1 and D2 connected to 50- $\Omega$ pullup resistors		140		ns

## 6.12 Supply Current

Bus loaded or unloaded (over recommended operating conditions unless otherwise noted)

PARAMETER	TEST CONDITIONS	MIN	TYP	MAX	UNIT
<b>DRIVER ENABLED, RECEIVER DISABLED</b>					
$I_{CC1}$ <sup>(1)</sup>	Logic-side supply current, $\overline{RE}$ at 0 V or $V_{CC}$ , DE at 0 V or $V_{CC1}$ , 3.3-V $V_{CC1}$		5	8	mA
$I_{CC1}$ <sup>(1)</sup>	Logic-side supply current, $\overline{RE}$ at 0 V or $V_{CC}$ , DE at 0 V or $V_{CC1}$ , 5-V $V_{CC1}$		7	12	mA
$I_{CC2}$ <sup>(1)</sup>	Bus-side supply current, $\overline{RE}$ at 0 V or $V_{CC}$ , DE at 0 V, No load		10	15	mA
$I_{CC2}$ <sup>(1)</sup>	Bus-side supply current, $\overline{RE}$ at 0 V or $V_{CC}$ , DE at $V_{CC1}$ , No load		10	15	mA
CMTI	Common-mode transient immunity, See Figure 28, $V_I = V_{CC1}$ or 0 V	25	50		kV/ $\mu$ s

- (1)  $I_{CC1}$  and  $I_{CC2}$  are measured when device is connected to external power supplies,  $V_{CC1}$  and  $V_{CC2}$ . In this case, D1 and D2 are open and disconnected from external transformer.

### 6.13 Switching Characteristics: Driver

All typical specs are at  $V_{CC1}=3.3V$ ,  $V_{CC2}=5V$ ,  $T_A=27^{\circ}C$ , (Min/Max specs are over recommended operating conditions unless otherwise noted)

PARAMETER	TEST CONDITIONS	MIN	TYP	MAX	UNIT
<b>20-Mbps</b>					
$t_{PHL}$ , $t_{PLH}$	Propagation delay		25	45	ns
PWD	Pulse width distortion <sup>(1)</sup> , $ t_{PHL} - t_{PLH} $		1	7.5	ns
$t_R$ , $t_F$	Differential output signal rise time and fall time		7	15	ns
$t_{PZH}$ , $t_{PZL}$	Propagation delay, high-impedance-to-high-level output and high-impedance-to-low-level output		25	55	ns
$t_{PHZ}$ , $t_{PLZ}$	Propagation delay, high-level-to-highimpedance output and low-level to highimpedance output		25	55	ns

(1) Also known as pulse skew.

### 6.14 Switching Characteristics: Receiver

All typical specs are at  $V_{CC1}=3.3V$ ,  $V_{CC2}=5V$ ,  $T_A=27^{\circ}C$ , (Min/Max specs are over recommended operating conditions unless otherwise noted)

PARAMETER	TEST CONDITIONS	MIN	TYP	MAX	UNIT
<b>20-Mbps</b>					
$t_r$ , $t_f$	Differential output rise time and fall time		1		ns
$t_{PHL}$ , $t_{PLH}$	Propagation delay		103	125	ns
PWD	Pulse Skew, $ t_{PHL} - t_{PLH} $		3	15	ns
$t_{PHZ}$ , $t_{PZH}$	Propagation delay, high-level-to-high-impedance output and highimpedance-to-high-level output		11	22	ns
$t_{PZL}$ , $t_{PLZ}$	Propagation delay, highimpedance-to-low-level output and low-level-to-high-impedance output		11	22	ns

### 6.15 Insulation Characteristics Curves

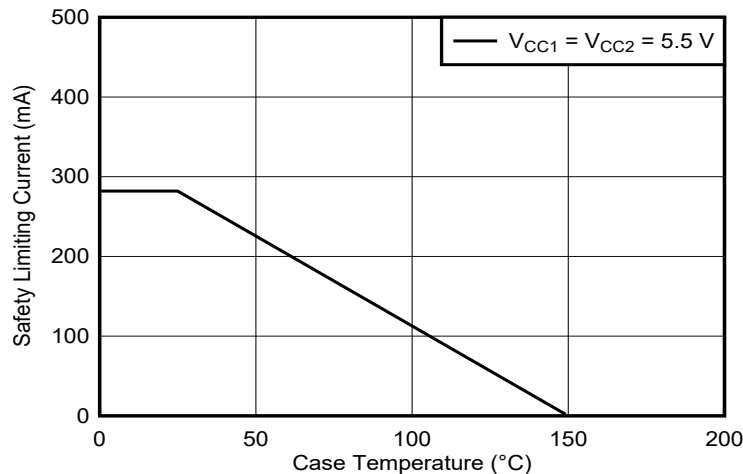


Figure 6-1. Thermal Derating Curve for Safety Limiting Power for DW-16 Package

## 6.16 Typical Characteristics

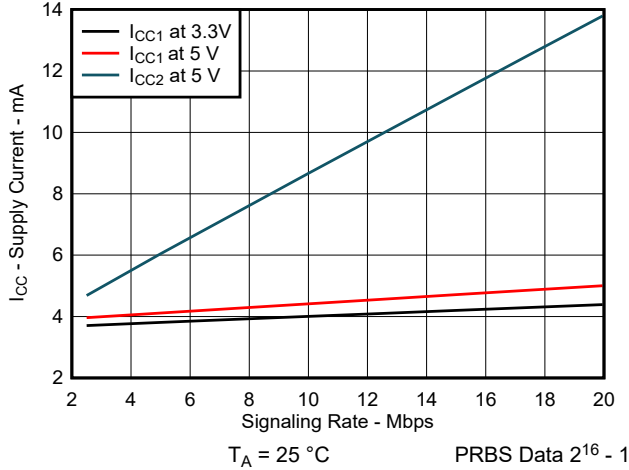


Figure 6-2. Supply Current vs Signaling Rate (No Load)

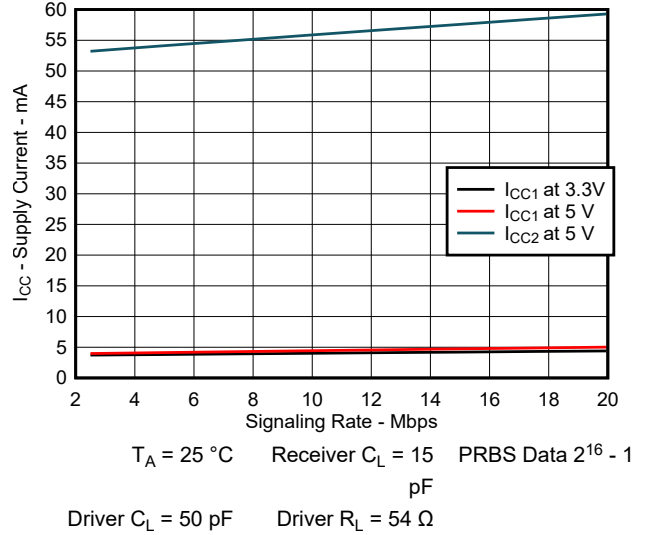


Figure 6-3. Supply Current vs Signaling Rate (With Load)

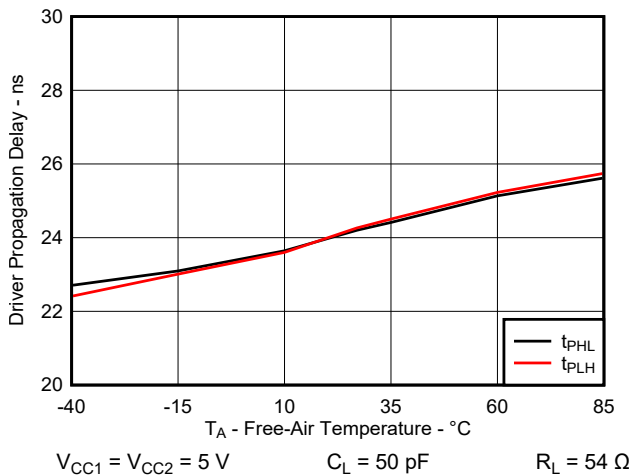


Figure 6-4. Driver Propagation Delay vs Free-Air Temperature

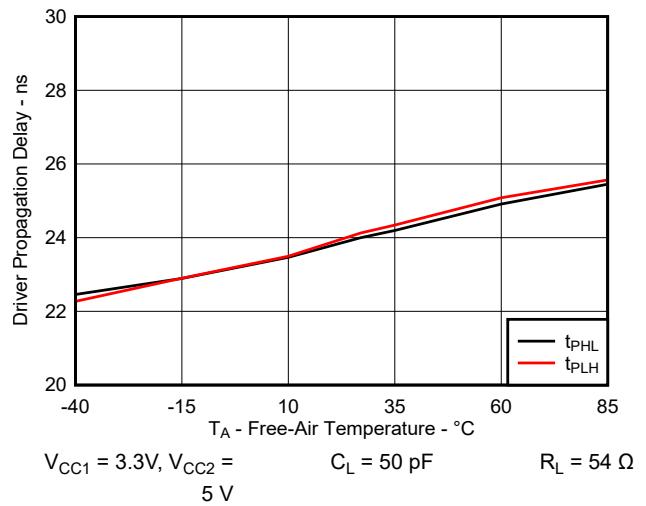


Figure 6-5. Driver Propagation Delay vs Free-Air Temperature

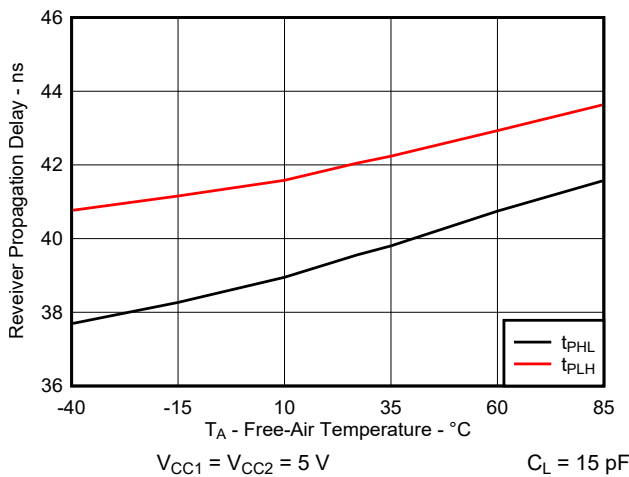


Figure 6-6. Receiver Propagation Delay vs Free-Air Temperature

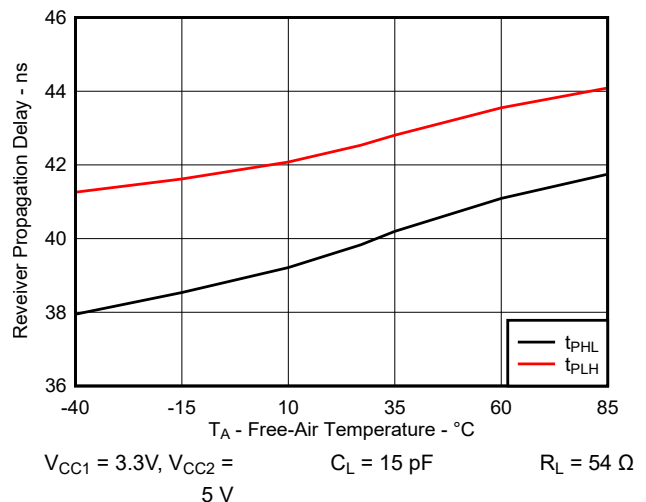


Figure 6-7. Receiver Propagation vs Free-Air Temperature

### 6.16 Typical Characteristics (continued)

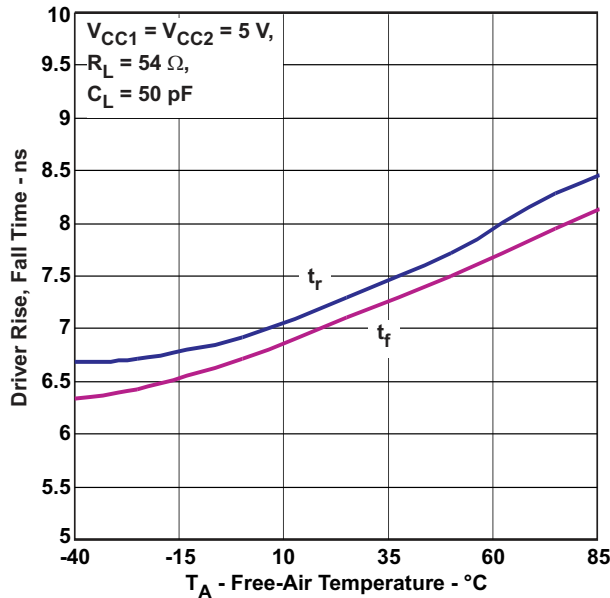


Figure 6-8. Driver Rise, Fall Time vs Free-Air Temperature

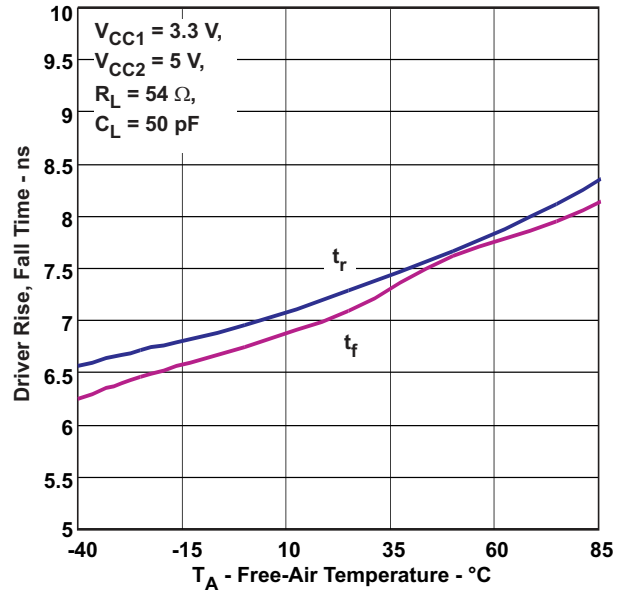


Figure 6-9. Driver Rise, Fall Time vs Free-Air Temperature

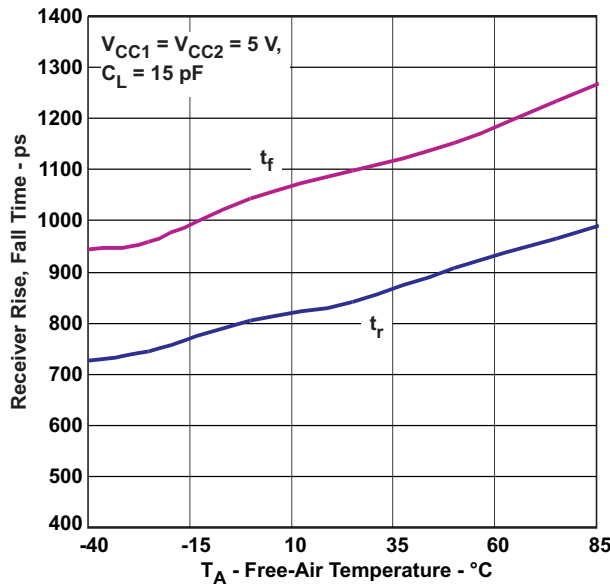


Figure 6-10. Receiver Rise, Fall Time vs Free-Air Temperature

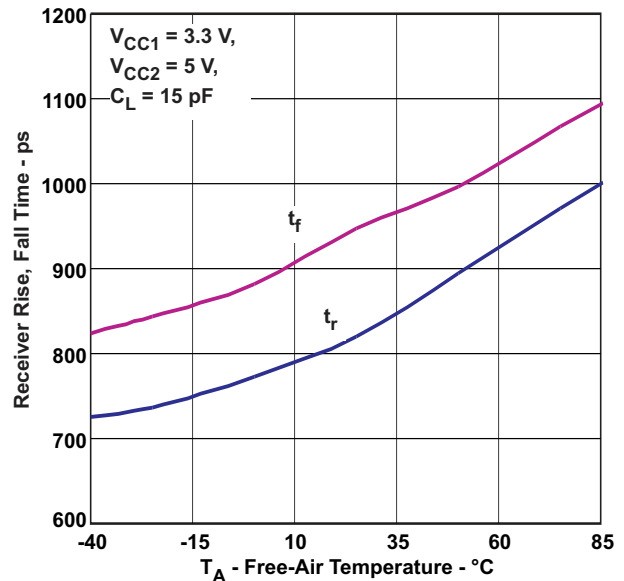


Figure 6-11. Receiver Rise, Fall Time vs Free-Air Temperature

### 6.16 Typical Characteristics (continued)

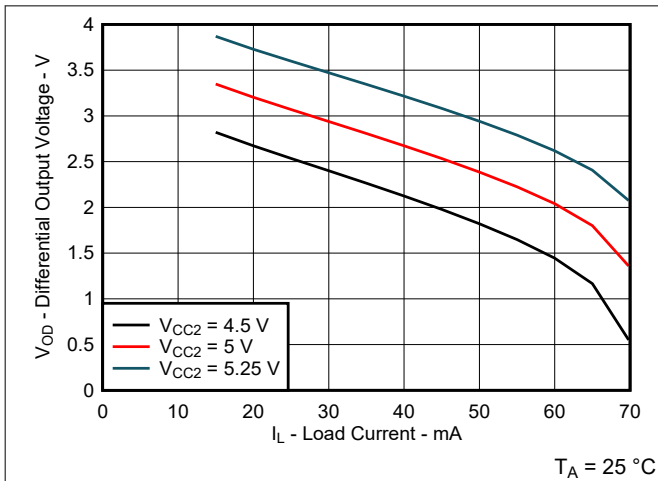


Figure 6-12. Driver Differential Output Voltage vs Load Current

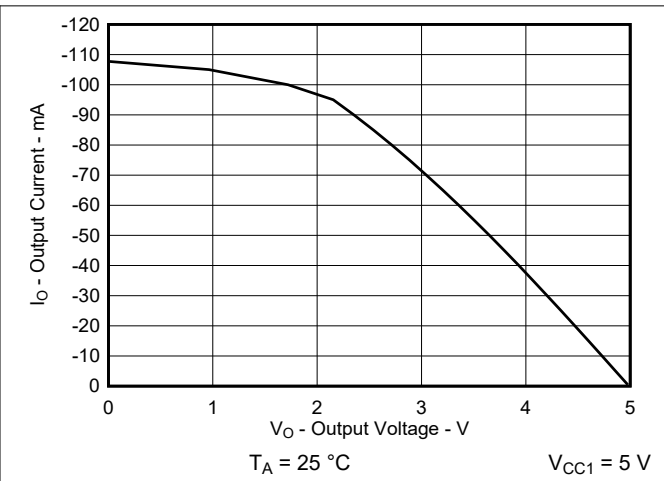


Figure 6-13. Receiver High-Level Output Current vs High-Level Output Voltage

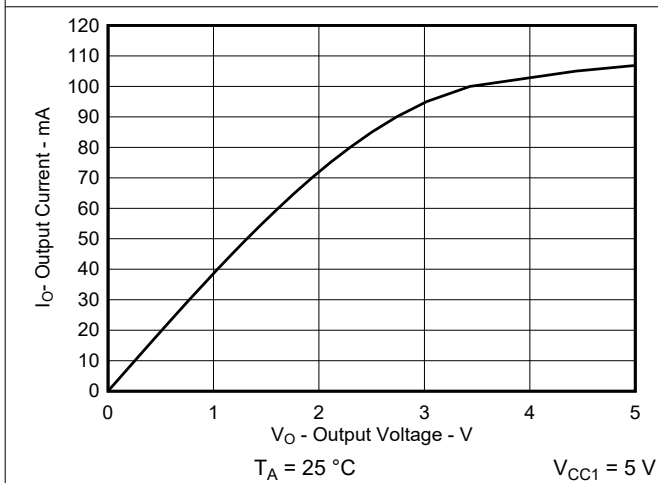


Figure 6-14. Receiver Low-Level Output Current vs Low-Level Output Voltage

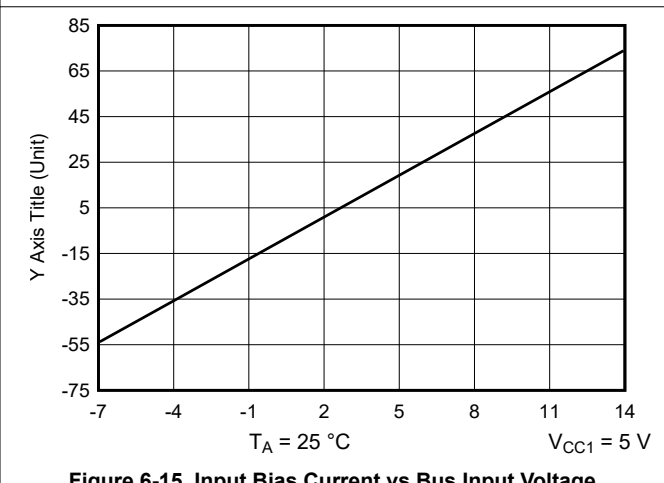


Figure 6-15. Input Bias Current vs Bus Input Voltage

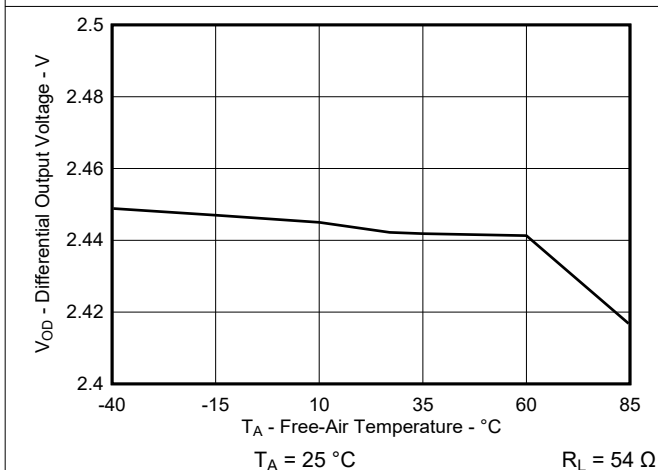


Figure 6-16. Differential Output Voltage vs Free-Air Temperature

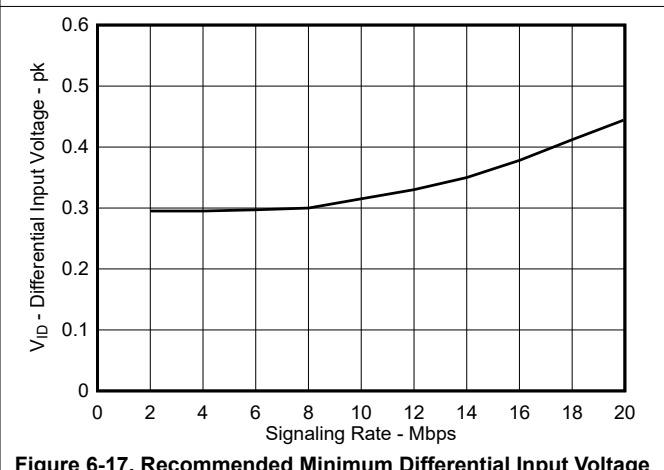


Figure 6-17. Recommended Minimum Differential Input Voltage vs Signaling Rate

## 7 Parameter Measurement Information

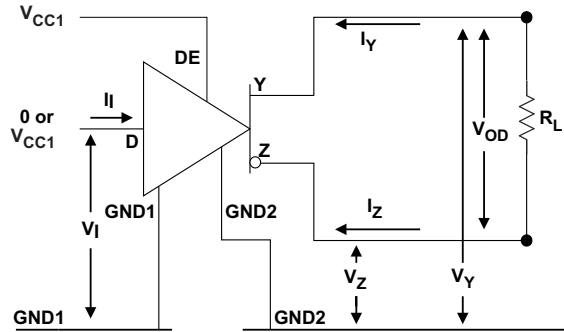


Figure 7-1. Driver  $V_{OD}$  Test and Current Definitions

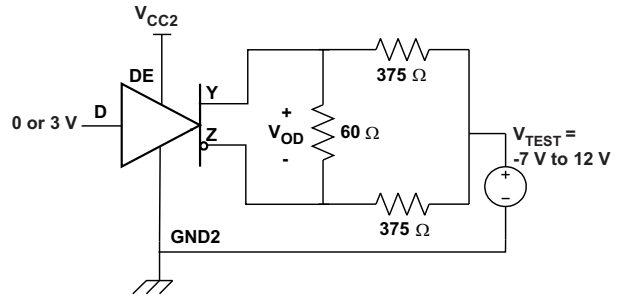
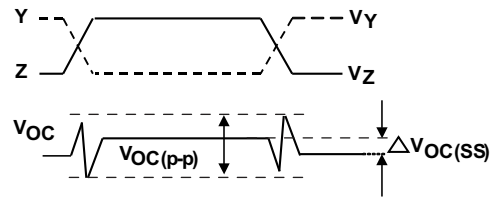
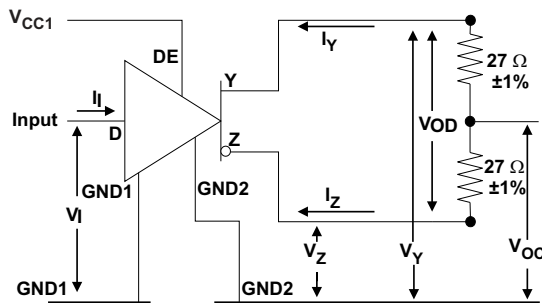
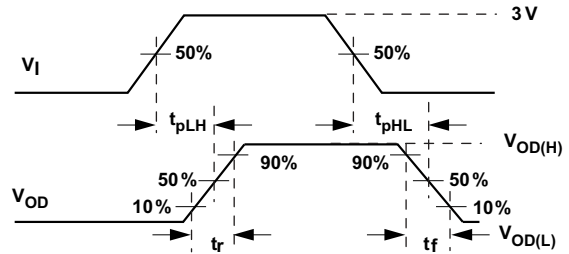
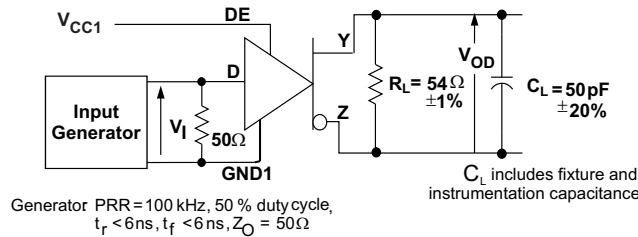


Figure 7-2. Driver  $V_{OD}$  With Common-Mode Loading Test Circuit



Input Generator PRR= 100 kHz, 50 % duty cycle,  $t_r < 6$  ns,  $t_f < 6$  ns,  $Z_O = 50 \Omega$

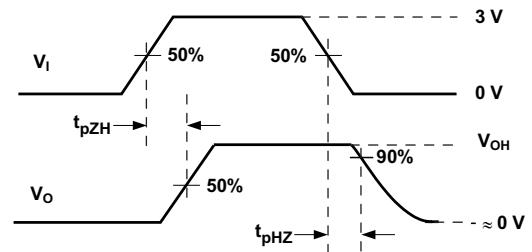
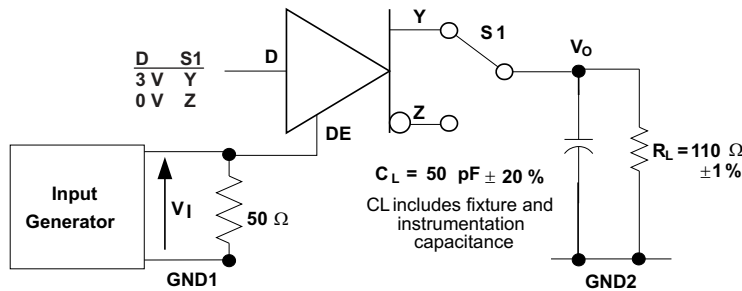
Figure 7-3. Test Circuit and Waveform Definitions For The Driver Common-Mode Output Voltage



Generator PRR=100 kHz, 50 % duty cycle,  $t_r < 6$  ns,  $t_f < 6$  ns,  $Z_O = 50 \Omega$

$C_L$  includes fixture and instrumentation capacitance

Figure 7-4. Driver Switching Test Circuit and Voltage Waveforms



Generator: PRR = 50 kHz, 50 % duty cycle,  $t_r < 6$  ns,  $t_f < 6$  ns,  $Z_O = 50 \Omega$

$C_L = 50 \text{ pF} \pm 20 \%$   
 $C_L$  includes fixture and instrumentation capacitance

Figure 7-5. Driver High-Level Output Enable and Disable Time Test Circuit and Voltage Waveforms

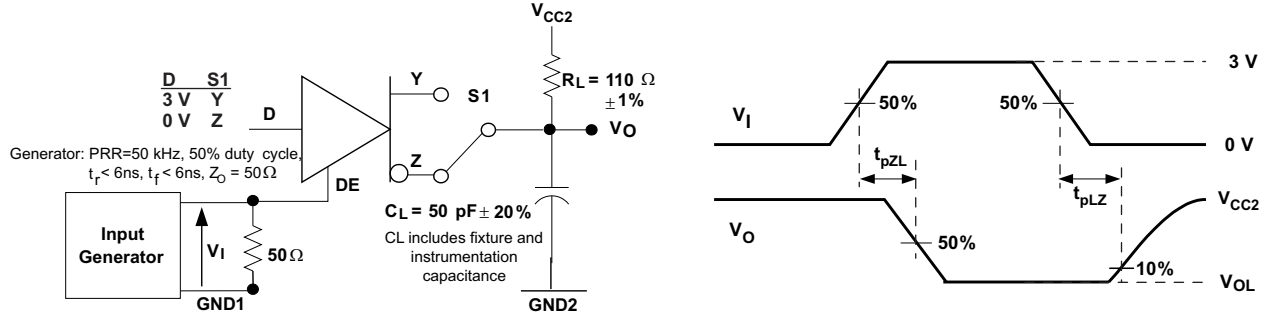


Figure 7-6. Driver Low-Level Output Enable and Disable Time Test Circuit and Voltage Waveform

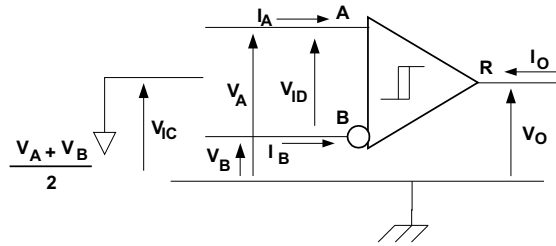


Figure 7-7. Receiver Voltage and Current Definitions

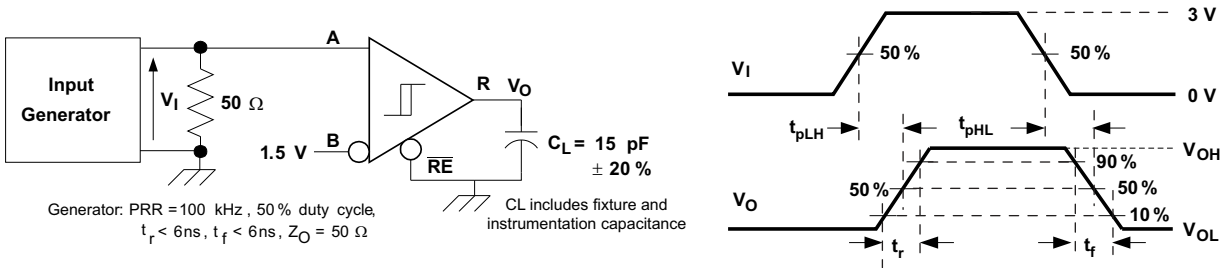


Figure 7-8. Receiver Switching Test Circuit and Waveforms

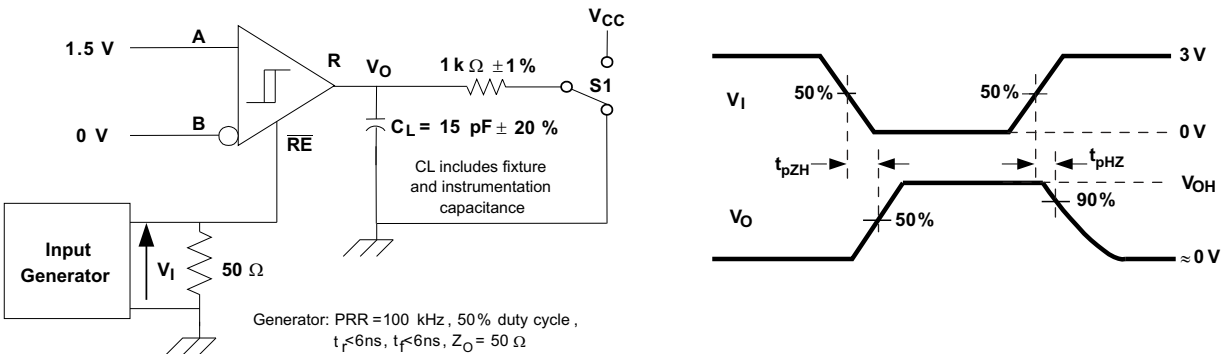


Figure 7-9. Receiver Enable Test Circuit and Waveforms, Data Output High



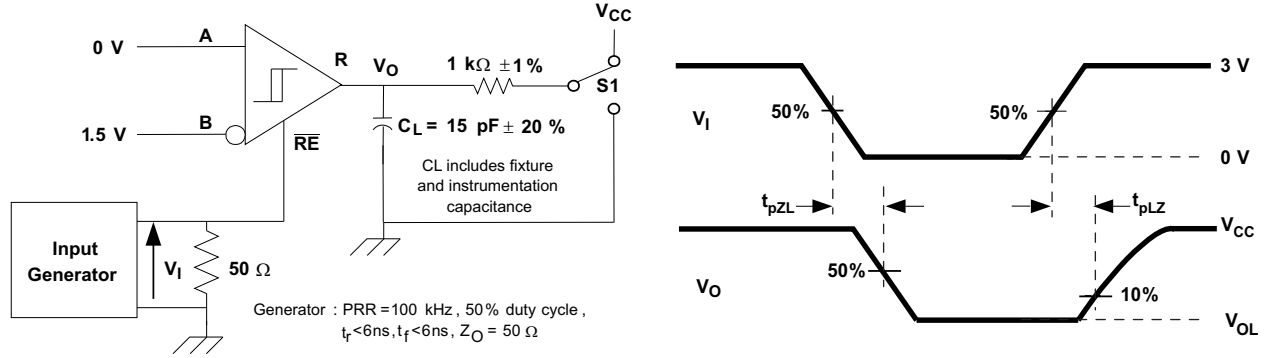


Figure 7-10. Receiver Enable Test Circuit and Waveforms, Data Output Low

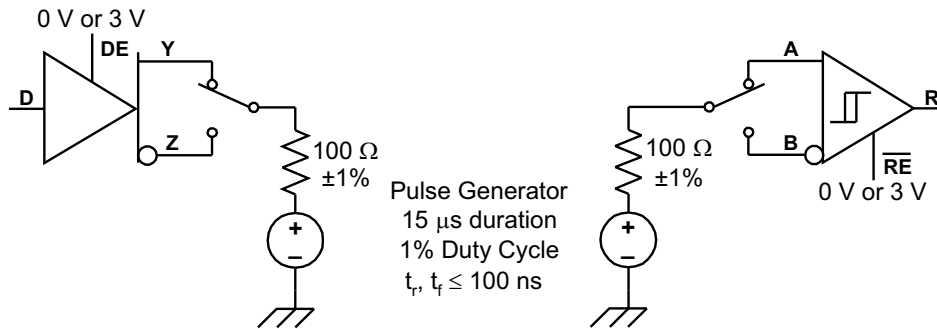


Figure 7-11. Transient Over-Voltage Test Circuit

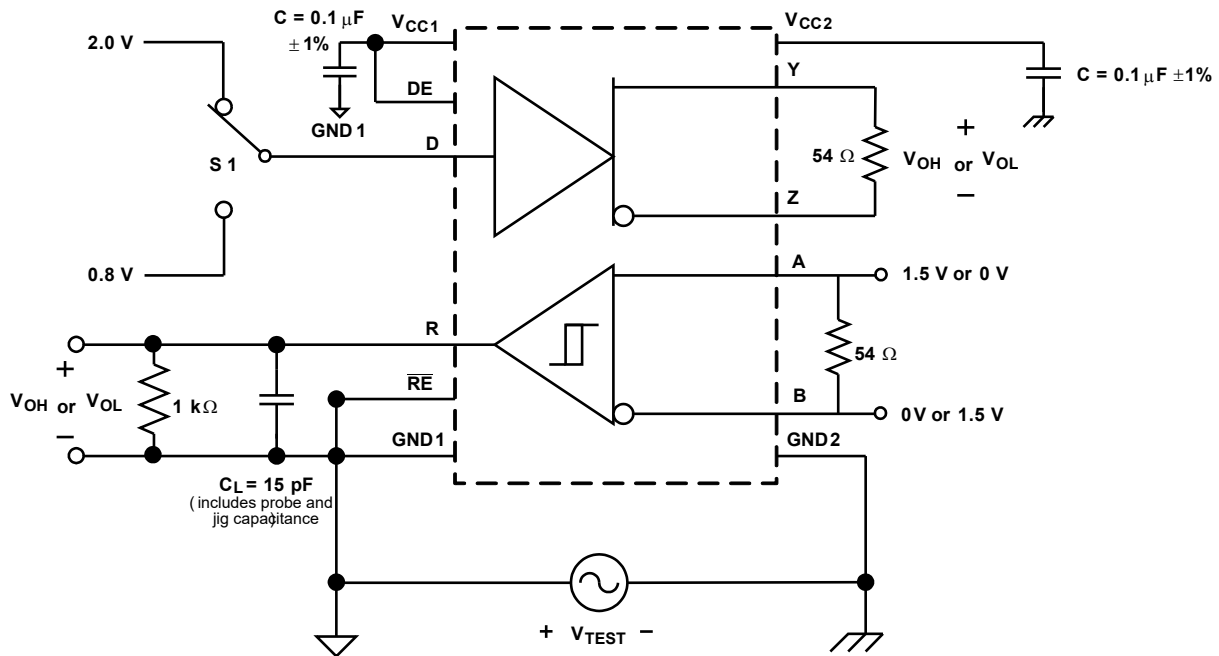


Figure 7-12. Common-Mode Transient Immunity Test Circuit

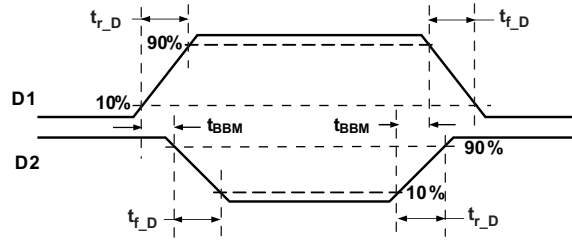


Figure 7-13. Transition Times and Break-Before-Make Time Delay for D1, D2 Outputs

## 8 Detailed Description

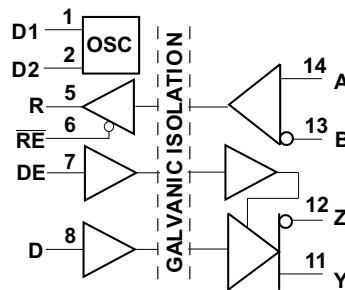
### 8.1 Overview

ISO3086T is an isolated full-duplex differential transceiver with integrated transformer driver. The integrated transformer driver supports elegant secondary power supply design. This device is rated to provide galvanic isolation up to 4242 V<sub>PK</sub> per VDE and 2500 V<sub>RMS</sub> per UL. It has active-high driver enable and active-low receiver enable to control the data flow. It is suitable for data transmission up to 20 Mbps.

When the driver enable pin, DE, is logic high, the differential outputs Y and Z follow the logic states at data input D. A logic high at D causes Y to turn high and Z to turn low. In this case the differential output voltage defined as  $V_{OD} = V_{(Y)} - V_{(Z)}$  is positive. When D is low, the output states reverse, Z turns high, Y becomes low, and  $V_{OD}$  is negative. When DE is low, both outputs turn high-impedance. In this condition the logic state at D is irrelevant. The DE pin has an internal pulldown resistor to ground, thus when left open the driver is disabled (high-impedance) by default. The D pin has an internal pullup resistor to V<sub>CC</sub>, thus, when left open while the driver is enabled, output Y turns high and Z turns low.

When the receiver enable pin,  $\overline{RE}$ , is logic low, the receiver is enabled. When the differential input voltage defined as  $V_{ID} = V_{(A)} - V_{(B)}$  is positive and higher than the positive input threshold, V<sub>IT+</sub>, the receiver output, R, turns high. When  $V_{ID}$  is negative and lower than the negative input threshold, V<sub>IT-</sub>, the receiver output, R, turns low. If  $V_{ID}$  is between V<sub>IT+</sub> and V<sub>IT-</sub> the output is indeterminate. When  $\overline{RE}$  is logic high or left open, the receiver output is high-impedance and the magnitude and polarity of  $V_{ID}$  are irrelevant. Internal biasing of the receiver inputs causes the output to go failsafe-high when the transceiver is disconnected from the bus (open-circuit), the bus lines are shorted (short-circuit), or the bus is not actively driven (idle bus).

### 8.2 Functional Block Diagram



### 8.3 Device Functional Modes

Table 8-1 and Table 8-2 are the function tables for the ISO3086T driver and receiver.

**Table 8-1. Driver Function Table**

INPUT	ENABLE	OUTPUTS	
(D)	(DE)	Y	Z
H	H	H	L
L	H	L	H
X	L	hi-Z	hi-Z
X	OPEN	hi-Z	hi-Z
OPEN	H	H	L

**Table 8-2. Receiver Function Table**

DIFFERENTIAL INPUT $V_{ID} = (V_A - V_B)$	ENABLE (RE)	OUTPUT (R)
$-0.01\text{ V} \leq V_{ID}$	L	H
$-0.2\text{ V} < V_{ID} < -0.01\text{ V}$	L	?
$V_{ID} \leq -0.2\text{ V}$	L	L
X	H	hi-Z
X	OPEN	hi-Z
Open circuit	L	H
Short Circuit	L	H
Idle (terminated) bus	L	H

### 8.3.1 Device I/O Schematics

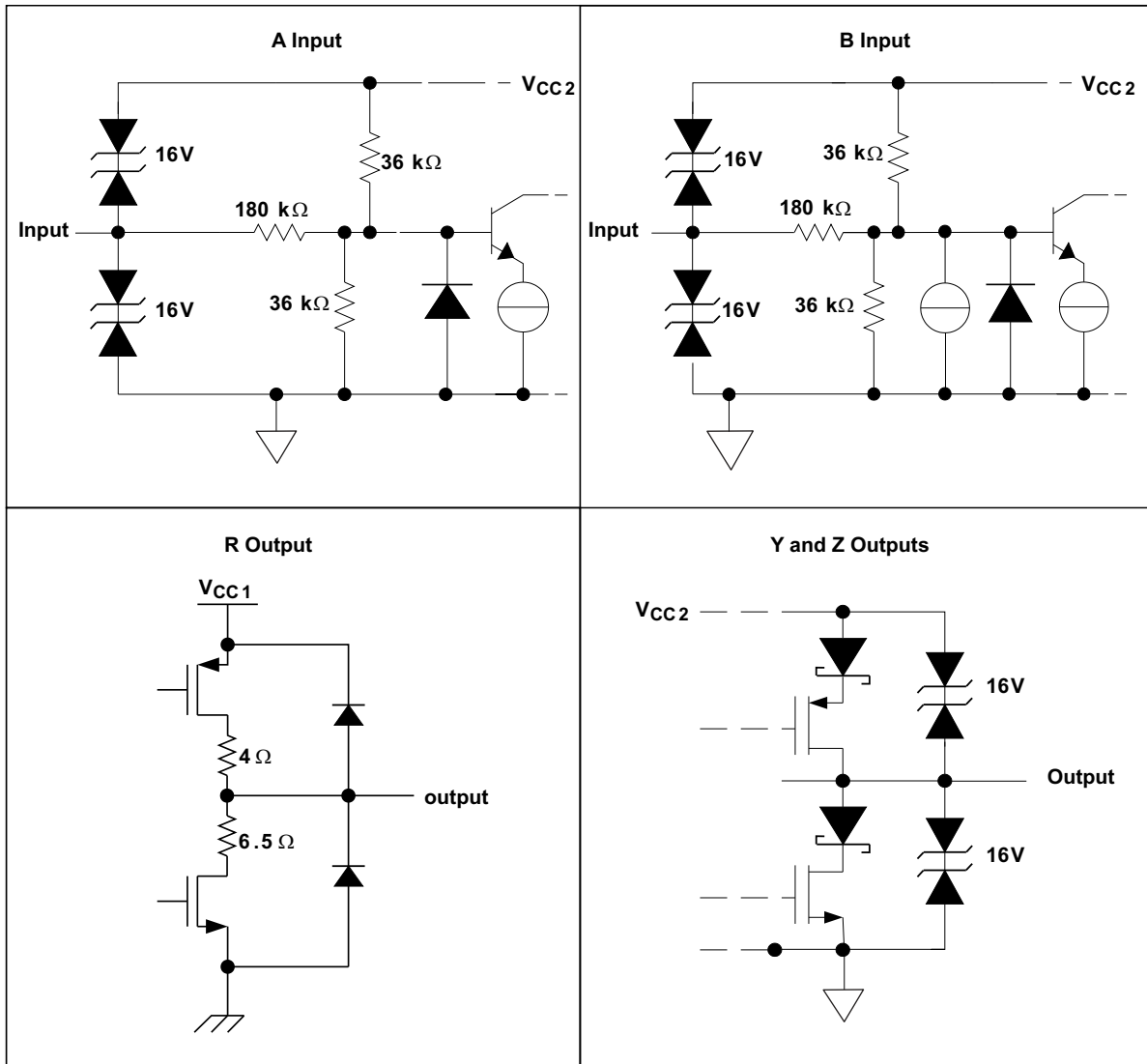


Figure 8-1. Equivalent Circuit Schematics

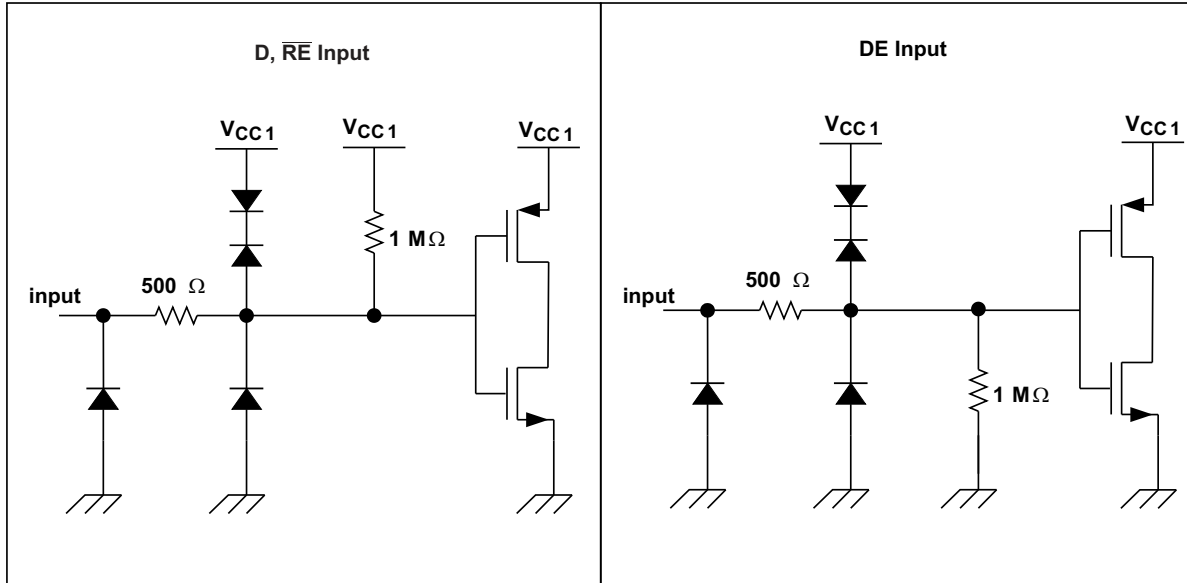


Figure 8-2. Equivalent Circuit Schematics

## 9 Application and Implementation

### Note

Information in the following applications sections is not part of the TI component specification, and TI does not warrant its accuracy or completeness. TI's customers are responsible for determining suitability of components for their purposes, as well as validating and testing their design implementation to confirm system functionality.

### 9.1 Application Information

The ISO308T consists of an RS-485 transceiver commonly used for asynchronous data transmissions. Full-duplex implementation requires two signal pairs (four wires), and allows each node to transmit data on one pair while simultaneously receiving data on the other pair. To eliminate line reflections, each cable end is terminated with a termination resistor,  $R(T)$ , whose value matches the characteristic impedance,  $Z_0$ , of the cable. This method, known as parallel termination, allows for higher data rates over longer cable length.

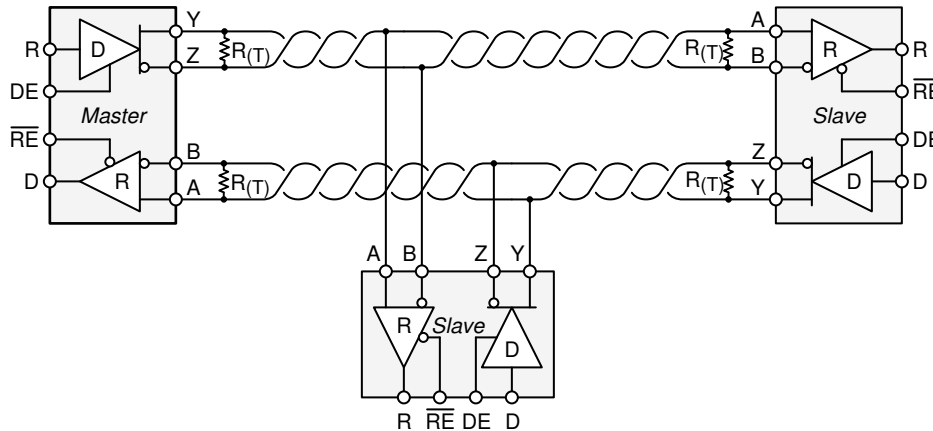


Figure 9-1. Half-Duplex Transceiver Configurations

### 9.2 Typical Application

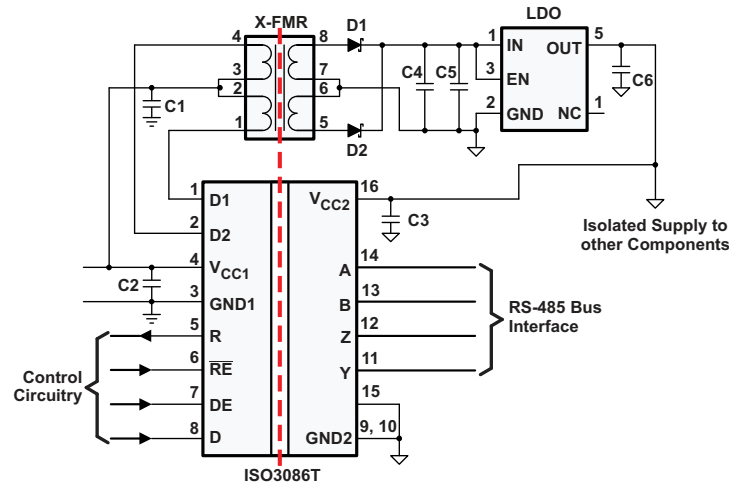


Figure 9-2. Typical Application Circuit

## 9.2.1 Design Requirements

RS-485 is a robust electrical standard suitable for long-distance networking that may be used in a wide range of applications with varying requirements, such as distance, data rate, and number of nodes.

**Table 9-1. Design Parameters**

PARAMETER	VALUE
Pullup and Pulldown Resistors	1 kΩ to 10 kΩ
Decoupling Capacitors	100 nF

## 9.2.2 Detailed Design Procedure

### 9.2.2.1 Transient Voltages

Isolation of a circuit insulates it from other circuits and earth so that noise develops across the insulation rather than circuit components. The most common noise threat to data-line circuits is voltage surges or electrical fast transients that occur after installation and the transient ratings of the ISO3086T are sufficient for all but the most severe installations. However, some equipment manufacturers use their ESD generators to test transient susceptibility of their equipment and can easily exceed insulation ratings. ESD generators simulate static discharges that may occur during device or equipment handling with low-energy but very high voltage transients.

[Figure 9-3](#) models the ISO3086T bus IO connected to a noise generator.  $C_{IN}$  and  $R_{IN}$  is the device and any other stray or added capacitance or resistance across the A or B pin to GND2,  $C_{ISO}$  and  $R_{ISO}$  is the capacitance and resistance between GND1 and GND2 of the ISO3086T plus those of any other insulation (transformer, etc.), and we assume stray inductance negligible. From this model, the voltage at the isolated bus return is shown in [Equation 1](#) and will always be less than 16 V from  $V_N$ .

$$V_{GND2} = V_N \frac{Z_{ISO}}{Z_{ISO} + Z_{IN}} \quad (1)$$

If the ISO3086T are tested as a stand-alone device,  $R_{IN} = 6 \times 10^4 \Omega$ ,  $C_{IN} = 16 \times 10^{-12} \text{ F}$ ,  $R_{ISO} = 10^9 \Omega$  and  $C_{ISO} = 10^{-12} \text{ F}$ .

In [Figure 9-3](#) the resistor ratio determines the voltage ratio at low frequency and it is the inverse capacitance ratio at high frequency. In the stand-alone case and for low frequency, use [Equation 2](#), or essentially all of noise appears across the barrier.

$$\frac{V_{GND2}}{V_N} = \frac{R_{ISO}}{R_{ISO} + R_{IN}} = \frac{10^9}{10^9 + 6 \times 10^4} \quad (2)$$

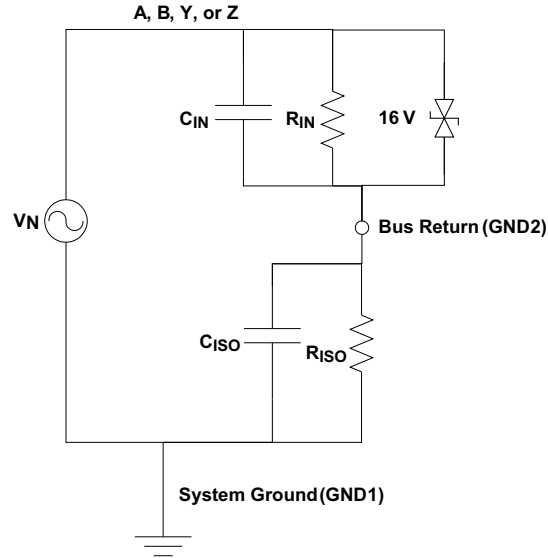
At very high frequency, [Equation 3](#) is true, and 94% of  $V_N$  appears across the barrier.

$$\frac{V_{GND2}}{V_N} = \frac{\frac{1}{C_{ISO}}}{\frac{1}{C_{ISO}} + \frac{1}{C_{IN}}} = \frac{1}{1 + \frac{C_{ISO}}{C_{IN}}} = \frac{1}{1 + \frac{1}{16}} = 0.94 \quad (3)$$

As long as  $R_{ISO}$  is greater than  $R_{IN}$  and  $C_{ISO}$  is less than  $C_{IN}$ , most of transient noise appears across the isolation barrier, as it should.

TI recommends not testing equipment transient susceptibility with ESD generators or consider product claims of ESD ratings above the barrier transient ratings of an isolated interface. ESD is best managed through recessing or covering connector pins in a conductive connector shell and installer training.

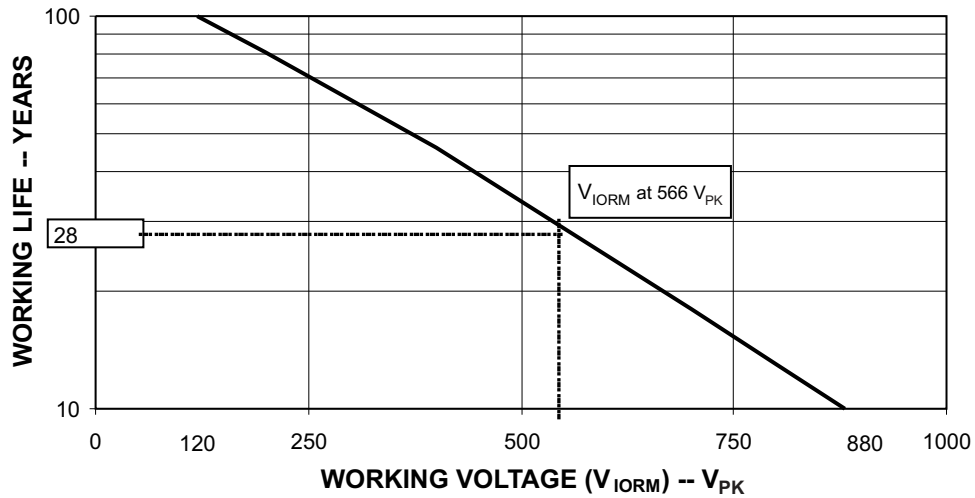




**Figure 9-3. Noise Model**

### 9.2.3 Application Curve

At maximum working voltage, ISO3086T isolation barrier has more than 28 years of life.



**Figure 9-4. Time-Dependent Dielectric Breakdown Test Results**

## 10 Power Supply Recommendations

To ensure reliable operation at all data rates and supply voltages, TI recommends a 0.1- $\mu$ F bypass capacitor at input and output supply pins ( $V_{CC1}$  and  $V_{CC2}$ ). The capacitors should be placed as close to the supply pins as possible. This device is used in applications where only a single primary-side power supply is available. Isolated power can be generated for the secondary-side with the help of integrated transformer driver.

## 11 Layout

### 11.1 Layout Guidelines

ON-chip IEC-ESD protection is good for laboratory and portable equipment but never sufficient for EFT and surge transients occurring in industrial environments. Therefore, robust and reliable bus node design requires the use of external transient protection devices. Because ESD and EFT transients have a wide frequency bandwidth from approximately 3-MHz to 3-GHz, high-frequency layout techniques must be applied during PCB design. A minimum of four layers is required to accomplish a low EMI PCB design (see [Figure 11-1](#)).

- Layer stacking should be in the following order (top-to-bottom): high-speed signal layer, ground plane, power plane, and low-frequency signal layer.
- Placing a solid ground plane next to the high-speed signal layer establishes controlled impedance for transmission line interconnects and provides an excellent low-inductance path for the return current flow.
- Placing the power plane next to the ground plane creates additional high-frequency bypass capacitance of approximately 100 pF/in<sup>2</sup>.
- Routing the slower speed control signals on the bottom layer allows for greater flexibility as these signal links usually have margin to tolerate discontinuities such as vias.
- Place the protection circuitry close to the bus connector to prevent noise transients from penetrating your board.
- Use  $V_{CC}$  and ground planes to provide low-inductance. High-frequency currents might follow the path of least inductance and not necessarily the path of least resistance.
- Design the protection components into the direction of the signal path. Do not force the transient currents to divert from the signal path to reach the protection device.
- Apply 0.1- $\mu$ F bypass capacitors as close as possible to the  $V_{CC}$ -pins of transceiver, UART, and controller ICs on the board.
- Use at least two vias for  $V_{CC}$  and ground connections of bypass capacitors and protection devices to minimize effective via-inductance.
- Use 1-k $\Omega$  to 10-k $\Omega$  pullup and pulldown resistors for enable lines to limit noise currents in these lines during transient events.
- Insert pulse-proof resistors into the A and B bus lines if the TVS clamping voltage is higher than the specified maximum voltage of the transceiver bus pins. These resistors limit the residual clamping current into the transceiver and prevent it from latching up.
- While pure TVS protection is sufficient for surge transients up to 1 kV, higher transients require metal-oxide varistors (MOVs) which reduce the transients to a few hundred volts of clamping voltage, and transient blocking units (TBUs) that limit transient current to less than 1 mA.
- Routing the high-speed traces on the top layer avoids the use of vias (and the introduction of their inductances) and allows for clean interconnects between the isolator and the transmitter and receiver circuits of the data link.

If an additional supply voltage plane or signal layer is needed, add a second power and ground plane system to the stack to keep it symmetrical. This makes the stack mechanically stable and prevents it from warping. Also the power and ground plane of each power system can be placed closer together, thus increasing the high-frequency bypass capacitance significantly.

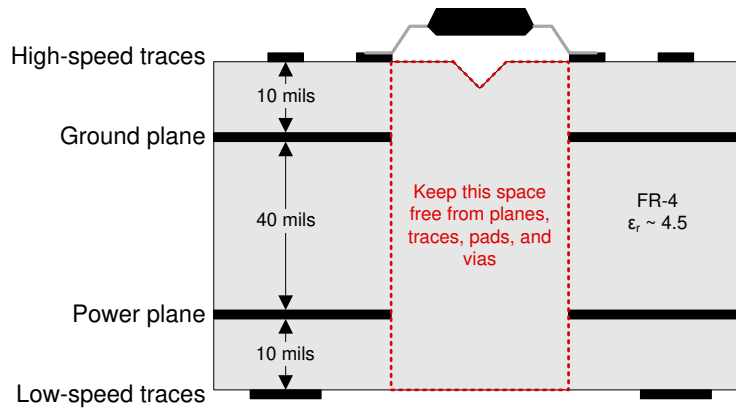
---

#### Note

For detailed layout recommendations, see Application Note *Digital Isolator Design Guide*, [SLLA284](#).

---

## 11.2 Layout Example



**Figure 11-1. Recommended Layer Stack**

## 12 Device and Documentation Support

### 12.1 Documentation Support

#### 12.1.1 Related Documentation

For related documentation, see the following:

- Texas Instruments, [Isolated, Full-Duplex, 20-Mbps, 3.3-V to 5-V RS-485 Interface reference guide](#)
- Texas Instruments, [Digital Isolator Design Guide application report](#)
- Texas Instruments, [Isolation Glossary application report](#)

### 12.2 Receiving Notification of Documentation Updates

To receive notification of documentation updates, navigate to the device product folder on [ti.com](#). Click on [Subscribe to updates](#) to register and receive a weekly digest of any product information that has changed. For change details, review the revision history included in any revised document.

### 12.3 Support Resources

[TI E2E™ support forums](#) are an engineer's go-to source for fast, verified answers and design help — straight from the experts. Search existing answers or ask your own question to get the quick design help you need.

Linked content is provided "AS IS" by the respective contributors. They do not constitute TI specifications and do not necessarily reflect TI's views; see TI's [Terms of Use](#).

### 12.4 Trademarks

TI E2E™ is a trademark of Texas Instruments.

All trademarks are the property of their respective owners.

### 12.5 Electrostatic Discharge Caution



This integrated circuit can be damaged by ESD. Texas Instruments recommends that all integrated circuits be handled with appropriate precautions. Failure to observe proper handling and installation procedures can cause damage.

ESD damage can range from subtle performance degradation to complete device failure. Precision integrated circuits may be more susceptible to damage because very small parametric changes could cause the device not to meet its published specifications.

### 12.6 Glossary

[TI Glossary](#) This glossary lists and explains terms, acronyms, and definitions.

## 13 Mechanical, Packaging, and Orderable Information

The following pages include mechanical, packaging, and orderable information. This information is the most current data available for the designated devices. This data is subject to change without notice and revision of this document. For browser-based versions of this data sheet, refer to the left-hand navigation.

**PACKAGING INFORMATION**

Orderable Device	Status (1)	Package Type	Package Drawing	Pins	Package Qty	Eco Plan (2)	Lead finish/ Ball material (6)	MSL Peak Temp (3)	Op Temp (°C)	Device Marking (4/5)	Samples
ISO3086TDW	LIFEBUY	SOIC	DW	16	40	RoHS & Green	NIPDAU	Level-2-260C-1 YEAR	-40 to 85	ISO3086T	
ISO3086TDWR	ACTIVE	SOIC	DW	16	2000	RoHS & Green	NIPDAU	Level-2-260C-1 YEAR	-40 to 85	ISO3086T	Samples

(1) The marketing status values are defined as follows:

**ACTIVE:** Product device recommended for new designs.

**LIFEBUY:** TI has announced that the device will be discontinued, and a lifetime-buy period is in effect.

**NRND:** Not recommended for new designs. Device is in production to support existing customers, but TI does not recommend using this part in a new design.

**PREVIEW:** Device has been announced but is not in production. Samples may or may not be available.

**OBSOLETE:** TI has discontinued the production of the device.

(2) **RoHS:** TI defines "RoHS" to mean semiconductor products that are compliant with the current EU RoHS requirements for all 10 RoHS substances, including the requirement that RoHS substance do not exceed 0.1% by weight in homogeneous materials. Where designed to be soldered at high temperatures, "RoHS" products are suitable for use in specified lead-free processes. TI may reference these types of products as "Pb-Free".

**RoHS Exempt:** TI defines "RoHS Exempt" to mean products that contain lead but are compliant with EU RoHS pursuant to a specific EU RoHS exemption.

**Green:** TI defines "Green" to mean the content of Chlorine (Cl) and Bromine (Br) based flame retardants meet JS709B low halogen requirements of <=1000ppm threshold. Antimony trioxide based flame retardants must also meet the <=1000ppm threshold requirement.

(3) MSL, Peak Temp. - The Moisture Sensitivity Level rating according to the JEDEC industry standard classifications, and peak solder temperature.

(4) There may be additional marking, which relates to the logo, the lot trace code information, or the environmental category on the device.

(5) Multiple Device Markings will be inside parentheses. Only one Device Marking contained in parentheses and separated by a "~" will appear on a device. If a line is indented then it is a continuation of the previous line and the two combined represent the entire Device Marking for that device.

(6) Lead finish/Ball material - Orderable Devices may have multiple material finish options. Finish options are separated by a vertical ruled line. Lead finish/Ball material values may wrap to two lines if the finish value exceeds the maximum column width.

**Important Information and Disclaimer:** The information provided on this page represents TI's knowledge and belief as of the date that it is provided. TI bases its knowledge and belief on information provided by third parties, and makes no representation or warranty as to the accuracy of such information. Efforts are underway to better integrate information from third parties. TI has taken and continues to take reasonable steps to provide representative and accurate information but may not have conducted destructive testing or chemical analysis on incoming materials and chemicals. TI and TI suppliers consider certain information to be proprietary, and thus CAS numbers and other limited information may not be available for release.

In no event shall TI's liability arising out of such information exceed the total purchase price of the TI part(s) at issue in this document sold by TI to Customer on an annual basis.

**TAPE AND REEL INFORMATION**

**QUADRANT ASSIGNMENTS FOR PIN 1 ORIENTATION IN TAPE**


\*All dimensions are nominal

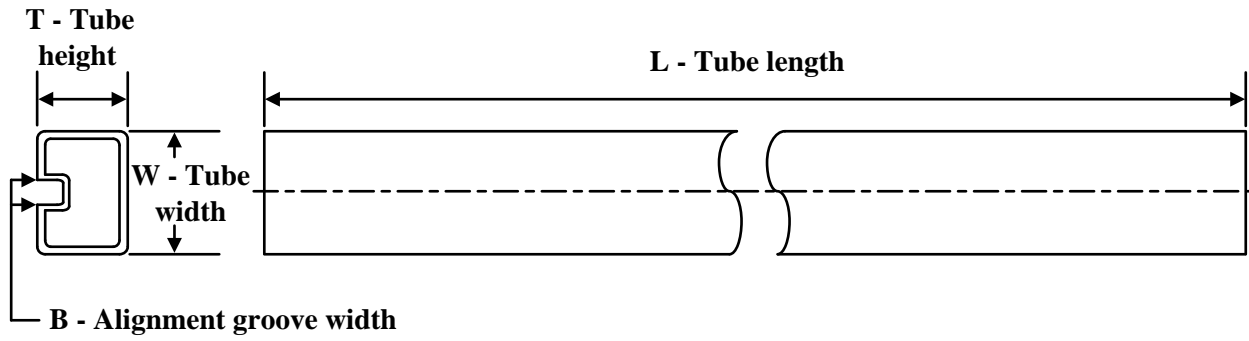
Device	Package Type	Package Drawing	Pins	SPQ	Reel Diameter (mm)	Reel Width W1 (mm)	A0 (mm)	B0 (mm)	K0 (mm)	P1 (mm)	W (mm)	Pin1 Quadrant
ISO3086TDWR	SOIC	DW	16	2000	330.0	16.4	10.75	10.7	2.7	12.0	16.0	Q1

**TAPE AND REEL BOX DIMENSIONS**


\*All dimensions are nominal

Device	Package Type	Package Drawing	Pins	SPQ	Length (mm)	Width (mm)	Height (mm)
ISO3086TDWR	SOIC	DW	16	2000	350.0	350.0	43.0



**TUBE**


\*All dimensions are nominal

Device	Package Name	Package Type	Pins	SPQ	L (mm)	W (mm)	T (μm)	B (mm)
ISO3086TDW	DW	SOIC	16	40	506.98	12.7	4826	6.6

## GENERIC PACKAGE VIEW

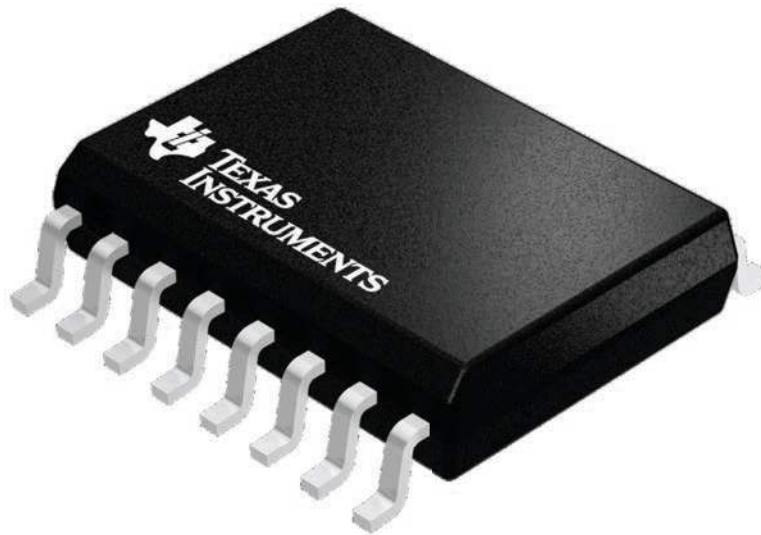
**DW 16**

**SOIC - 2.65 mm max height**

7.5 x 10.3, 1.27 mm pitch

SMALL OUTLINE INTEGRATED CIRCUIT

This image is a representation of the package family, actual package may vary.  
Refer to the product data sheet for package details.



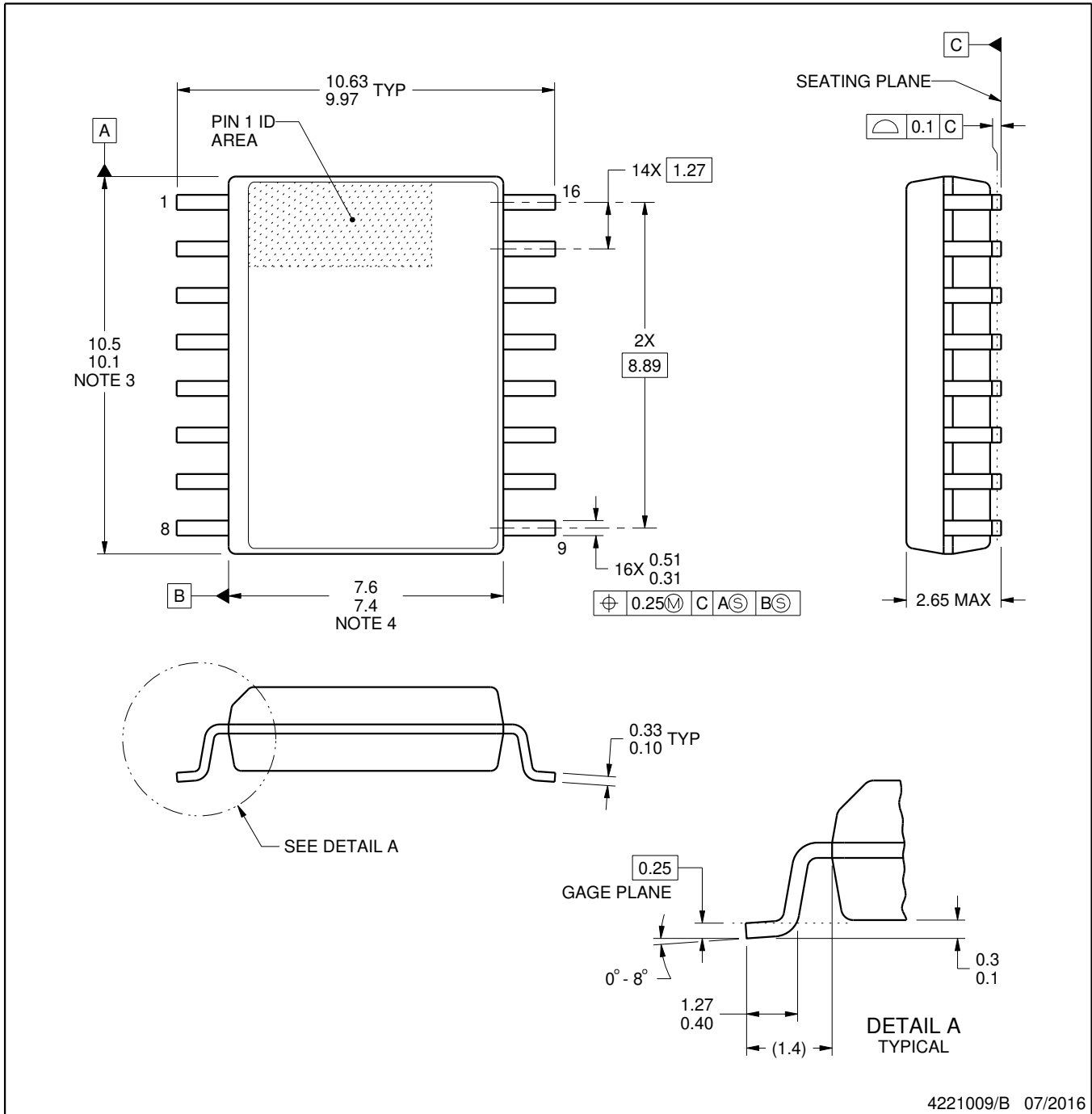
4224780/A



# DW0016B

# PACKAGE OUTLINE SOIC - 2.65 mm max height

SOIC



4221009/B 07/2016

### NOTES:

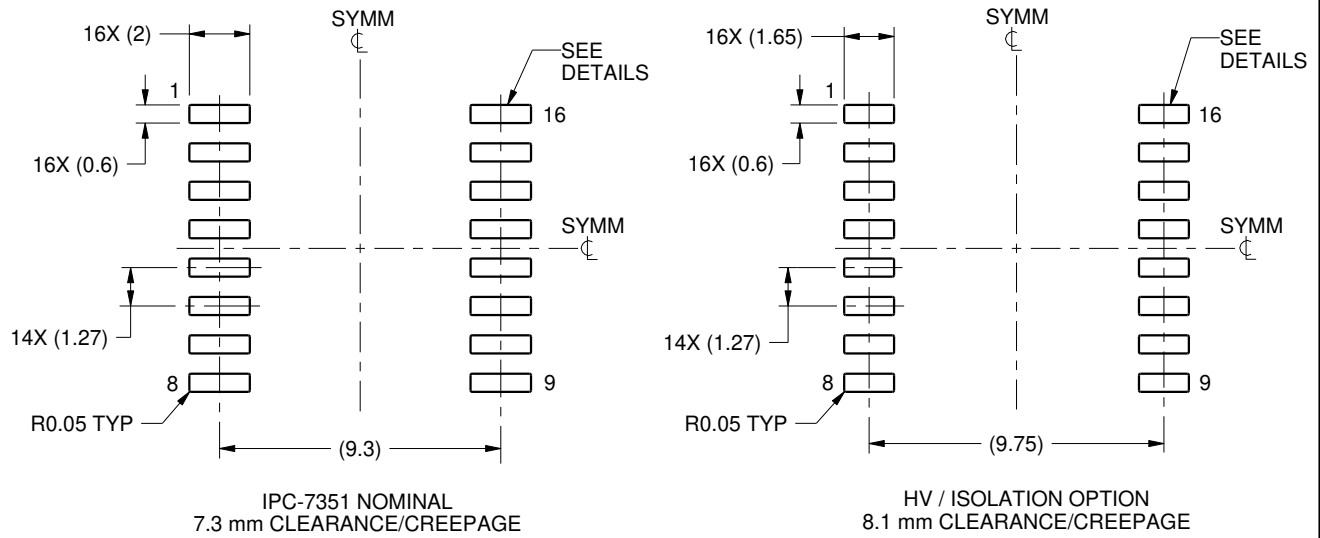
1. All linear dimensions are in millimeters. Dimensions in parenthesis are for reference only. Dimensioning and tolerancing per ASME Y14.5M.
2. This drawing is subject to change without notice.
3. This dimension does not include mold flash, protrusions, or gate burrs. Mold flash, protrusions, or gate burrs shall not exceed 0.15 mm, per side.
4. This dimension does not include interlead flash. Interlead flash shall not exceed 0.25 mm, per side.
5. Reference JEDEC registration MS-013.

# EXAMPLE BOARD LAYOUT

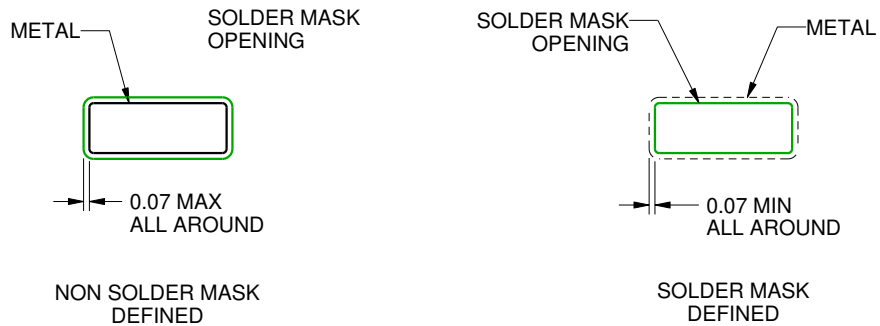
DW0016B

SOIC - 2.65 mm max height

SOIC



LAND PATTERN EXAMPLE  
SCALE:4X



SOLDER MASK DETAILS

4221009/B 07/2016

NOTES: (continued)

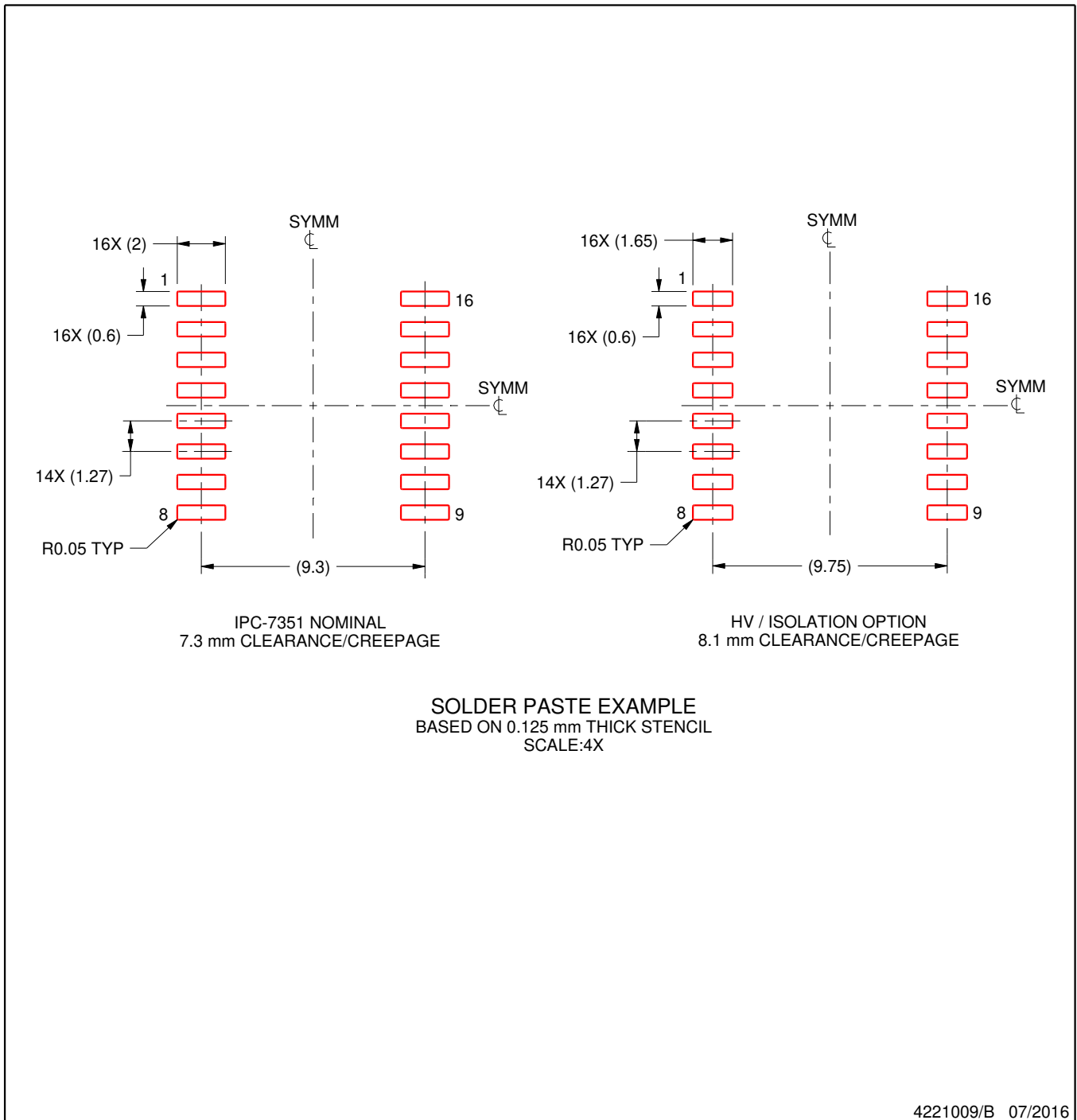
- 6. Publication IPC-7351 may have alternate designs.
- 7. Solder mask tolerances between and around signal pads can vary based on board fabrication site.

# EXAMPLE STENCIL DESIGN

DW0016B

SOIC - 2.65 mm max height

SOIC



NOTES: (continued)

8. Laser cutting apertures with trapezoidal walls and rounded corners may offer better paste release. IPC-7525 may have alternate design recommendations.
9. Board assembly site may have different recommendations for stencil design.

## IMPORTANT NOTICE AND DISCLAIMER

TI PROVIDES TECHNICAL AND RELIABILITY DATA (INCLUDING DATA SHEETS), DESIGN RESOURCES (INCLUDING REFERENCE DESIGNS), APPLICATION OR OTHER DESIGN ADVICE, WEB TOOLS, SAFETY INFORMATION, AND OTHER RESOURCES "AS IS" AND WITH ALL FAULTS, AND DISCLAIMS ALL WARRANTIES, EXPRESS AND IMPLIED, INCLUDING WITHOUT LIMITATION ANY IMPLIED WARRANTIES OF MERCHANTABILITY, FITNESS FOR A PARTICULAR PURPOSE OR NON-INFRINGEMENT OF THIRD PARTY INTELLECTUAL PROPERTY RIGHTS.

These resources are intended for skilled developers designing with TI products. You are solely responsible for (1) selecting the appropriate TI products for your application, (2) designing, validating and testing your application, and (3) ensuring your application meets applicable standards, and any other safety, security, regulatory or other requirements.

These resources are subject to change without notice. TI grants you permission to use these resources only for development of an application that uses the TI products described in the resource. Other reproduction and display of these resources is prohibited. No license is granted to any other TI intellectual property right or to any third party intellectual property right. TI disclaims responsibility for, and you will fully indemnify TI and its representatives against, any claims, damages, costs, losses, and liabilities arising out of your use of these resources.

TI's products are provided subject to [TI's Terms of Sale](#) or other applicable terms available either on [ti.com](https://www.ti.com) or provided in conjunction with such TI products. TI's provision of these resources does not expand or otherwise alter TI's applicable warranties or warranty disclaimers for TI products.

TI objects to and rejects any additional or different terms you may have proposed.

Mailing Address: Texas Instruments, Post Office Box 655303, Dallas, Texas 75265  
Copyright © 2023, Texas Instruments Incorporated