

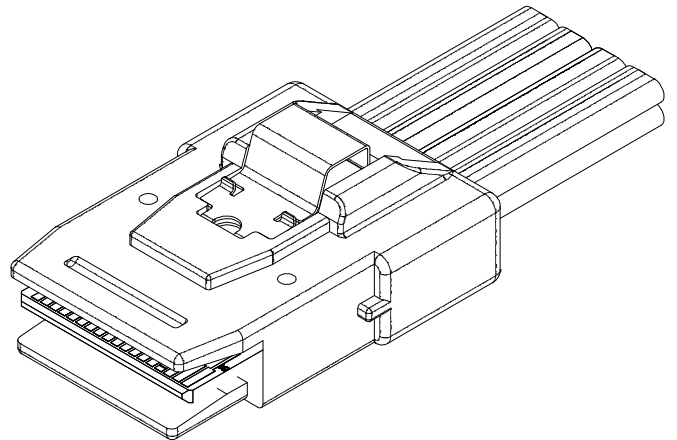

PRODUCT SPECIFICATION

iPASS 0.8 mm PITCH I/O CONNECTOR

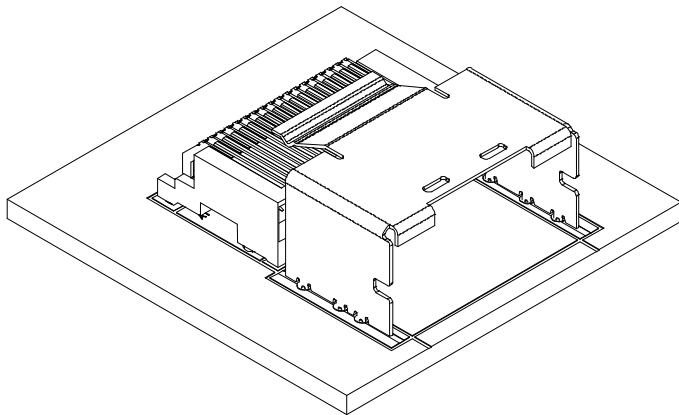
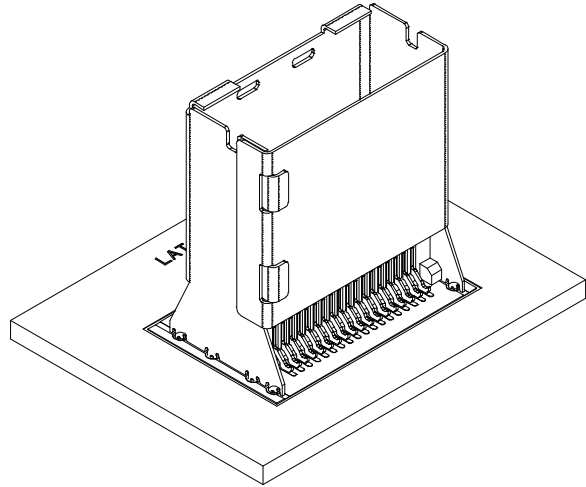

REVISION: B3	ECR/ECN INFORMATION: EC No: UCP2015-0373 DATE: 2014 / 07 / 29	TITLE: PRODUCT SPECIFICATION INTERNAL iPass I/O CONNECTOR & CABLE	SHEET No. 1 of 17
DOCUMENT NUMBER: PS-75783-001	CREATED / REVISED BY: KBINGHAM	CHECKED BY: TMCCLELLAND	APPROVED BY: TMCCLELLAND



PRODUCT SPECIFICATION

TABLE OF CONTENTS

1.0	SCOPE	4
2.0	PRODUCT DESCRIPTION	4
2.1	PRODUCT NAME AND SERIES NUMBER(S).....	4
2.2	DIMENSION, MATERIALS, PLATING AND MARKINGS.....	4
2.3	SAFETY AGENCY APPROVALS.....	4
2.4	PIN ASSIGNMENTS.....	4
2.5	ADDITIONAL GENERAL SPECIFICATIONS.....	4
3.0	APPLICABLE DOCUMENTS AND SPECIFICATIONS	5
3.1	MOLEX DOCUMENTS.....	5
3.2	INDUSTRY DOCUMENTS.....	5
4.0	QUALIFICATION	5
5.0	RATINGS	5
5.1	VOLTAGE.....	5
5.2	CURRENT.....	5
5.3	TEMPERATURE.....	5
5.4	DURABILITY.....	5
6.0	PERFORMANCE (MECHANICAL & ENVIRONMENTAL)	6
6.1	TEST GROUP 1.....	6
6.2	TEST GROUP 2.....	7
6.3	TEST GROUP 3.....	8
6.4	TEST GROUP 7.....	9
6.5	MECHANICAL TEST GROUP 1.....	10
6.6	MECHANICAL TEST GROUP 2.....	10
6.7	MECHANICAL TEST GROUP 3.....	11
6.8	MECHANICAL TEST GROUP 4.....	11
6.9	MECHANICAL TEST GROUP 5.....	11
6.10	MECHANICAL TEST GROUP 6.....	12
6.11	MECHANICAL TEST GROUP 7.....	12
6.12	MECHANICAL TEST GROUP 8.....	12
7.0	PERFORMANCE (HIGH SPEED CHARACTERIZATION)	13
7.1	SIGNAL INTEGRITY REQUIREMENTS (CONNECTOR ONLY).....	13
7.2	SIGNAL INTEGRITY REQUIREMENTS (CONNECTOR & CABLE SYSTEM).....	14
8.0	PACKAGING	15
8.1	CONNECTOR AND SHELL.....	15
8.2	PLUG AND CABLE ASSEMBLY.....	15
8.3	PLUG AND CABLE ASSEMBLY.....	15
9.0	GAGES AND FIXTURES	16

REVISION: B3	EGR/ECN INFORMATION: EC No: UCP2015-0373 DATE: 2014 / 07 / 29	TITLE: PRODUCT SPECIFICATION INTERNAL iPass I/O CONNECTOR & CABLE	SHEET No. 2 of 17
DOCUMENT NUMBER: PS-75783-001	CREATED / REVISED BY: KBINGHAM	CHECKED BY: TMCCLELLAND	APPROVED BY: TMCCLELLAND



PRODUCT SPECIFICATION

10.0	OTHER INFORMATION	17
10.1	MOLEX CONNECTOR ONLY TEST PROFILE	17
10.2	INVERTED SMT APPLICATION	17

REVISION: B3	ECR/ECN INFORMATION: EC No: UCP2015-0373 DATE: 2014 / 07 / 29	TITLE: PRODUCT SPECIFICATION INTERNAL iPass I/O CONNECTOR & CABLE	SHEET No. 3 of 17
DOCUMENT NUMBER: PS-75783-001	CREATED / REVISED BY: KBINGHAM	CHECKED BY: TMCCLELLAND	APPROVED BY: TMCCLELLAND



PRODUCT SPECIFICATION

1.0 SCOPE

This Product Specification covers this 0.8 mm centerline (pitch) printed circuit board (PCB) connector series and cable assemblies.

2.0 PRODUCT DESCRIPTION

2.1 PRODUCT NAME AND SERIES NUMBER(S)

Product Name: iPass Connector Family
 Connector & Shell Series: 75783 / 75784
 Plug & Cable Series: 74562 / 74563 / 79536 / 79575 / 79576
 74571 / 74573 / 74586 / 74596 / 111018 / 111039

2.2 DIMENSION, MATERIALS, PLATING AND MARKINGS

See the appropriate sales drawing for information on dimensions, materials, plating, marking, and footprint patterns.

2.3 SAFETY AGENCY APPROVALS

UL file: E29179
 CSA file: 310648

2.4 PIN ASSIGNMENTS

Pin assignment may vary depending on the cable assembly configuration. Different configurations will have different part numbers within the series. Reference the appropriate cable sales drawing of the specific part number for the correct pin assignment.

2.5 ADDITIONAL GENERAL SPECIFICATIONS

- Plug PCB:
- Material is FR4
 - Overall thickness of 1mm over pads
 - Contacts are 0.38µm minimum hard gold plated over 1.27µm minimum thick nickel plating
- Plug Over-mold:
- Glass reinforced thermoplastic
 - Color is black
- Bulk Cable:
- See specific sales drawing

REVISION: B3	ECR/ECN INFORMATION: EC No: UCP2015-0373 DATE: 2014 / 07 / 29	TITLE: PRODUCT SPECIFICATION INTERNAL iPass I/O CONNECTOR & CABLE	SHEET No. 4 of 17
DOCUMENT NUMBER: PS-75783-001	CREATED / REVISED BY: KBINGHAM	CHECKED BY: TMCCLELLAND	APPROVED BY: TMCCLELLAND



PRODUCT SPECIFICATION

3.0 APPLICABLE DOCUMENTS AND SPECIFICATIONS

3.1 MOLEX DOCUMENTS

AS-75783-001	Application Specification
PK-75577-001	Packaging Specification
PK-75783-001	Packaging Specification
SD-75577-002	iPass Vertical Connector
SD-75783-001	iPass Right Angle with Shell
SD-75784-001	iPass Vertical with Shell
PS-45499-002	Cosmetic Specification
SMES-152	Solderability

3.2 INDUSTRY DOCUMENTS

EIA 364 Series	Electrical Connector Test Procedures Including Environmental Classifications with Test Procedures
EIA 364-1000	Environmental Test Methodology for Assessing the Performance of Connectors and Sockets Used in Business Office Applications

4.0 QUALIFICATION

Laboratory condition and sample selection are in accordance with EIA 364

5.0 RATINGS

5.1 VOLTAGE

48 Volts AC (RMS)/DC Max.

5.2 CURRENT

1.0 Amps Max.

5.3 TEMPERATURE

Operating:	-40°C to +80°C
Non-operating:	-55°C to +80°C

5.4 DURABILITY

PL1 – Performance Level 1 – 0.38 µm Au - 50 cycles
 PL2 – Performance Level 2 – 0.76 µm Au – 250 cycles

REVISION: B3	ECR/ECN INFORMATION: EC No: UCP2015-0373 DATE: 2014 / 07 / 29	TITLE: PRODUCT SPECIFICATION INTERNAL iPass I/O CONNECTOR & CABLE	SHEET No. 5 of 17
DOCUMENT NUMBER: PS-75783-001	CREATED / REVISED BY: KBINGHAM	CHECKED BY: TMCCLELLAND	APPROVED BY: TMCCLELLAND



PRODUCT SPECIFICATION

6.0 PERFORMANCE (MECHANICAL & ENVIRONMENTAL)

6.1 TEST GROUP 1

ITEM	TEST	TEST PROCEDURE	CONDITION	REQUIREMENT	ACTUAL
1	Low Level Contact Resistance	EIA 364-23; apply a maximum voltage of 20 mV and a current of 100 mA.	Mated	PL1 – baseline PL2 – baseline	PL1 – N/A PL2 – N/A
2	Durability (precondition)	EIA-364-09; perform plug & unplug cycles: PL1 (20), PL2 (50).		No evidence of physical damage	PASS
3	Temperature Life	EIA-364-17, method A, Test Condition 3 at 105°±2°C PL1 – 72 hours PL2 – 120 hours	Mated	None	
4	Low Level Contact Resistance	EIA 364-23; apply a maximum voltage of 20 mV and a current of 100 mA.	Mated	PL1 – <10 mΩ Δ max PL2 – <10 mΩ Δ max from initial	PL1 – <10 mΩ Δ PL2 – <10 mΩ Δ
5	Reseating	Manually unplug & plug the connector, 3 cycles		No evidence of physical damage	PASS
6	Low Level Contact Resistance	EIA 364-23; apply a maximum voltage of 20 mV and a current of 100 mA.	Mated	PL1 – <10 mΩ Δ max PL2 – <10 mΩ Δ max from initial	PL1 – <10 mΩ Δ PL2 – <10 mΩ Δ

REVISION: B3	EGR/ECN INFORMATION: EC No: UCP2015-0373 DATE: 2014 / 07 / 29	TITLE: PRODUCT SPECIFICATION INTERNAL iPass I/O CONNECTOR & CABLE	SHEET No. 6 of 17
DOCUMENT NUMBER: PS-75783-001	CREATED / REVISED BY: KBINGHAM	CHECKED BY: TMCCLELLAND	APPROVED BY: TMCCLELLAND



PRODUCT SPECIFICATION

6.2 TEST GROUP 2

ITEM	TEST	TEST PROCEDURE	CONDITION	REQUIREMENT	ACTUAL
1	Low Level Contact Resistance	EIA 364-23; apply a maximum voltage of 20 mV and a current of 100 mA.	Mated	PL1 – baseline PL2 – baseline	PL1 – N/A PL2 – N/A
2	Durability (precondition)	EIA-364-09; perform plug & unplug cycles: PL1 (20), PL2 (50).		No evidence of physical damage	PASS
3	Thermal Shock	EIA 364-32, Method A, test condition I (10 cycles)	Mated	None	
4	Low Level Contact Resistance	EIA 364-23; apply a maximum voltage of 20 mV and a current of 100 mA.	Mated	PL1 – <10 mΩ Δ max PL2 – <10 mΩ Δ max from initial	PL1 – <10 mΩ Δ PL2 – <10 mΩ Δ
5	Cyclic Temperature & Humidity	EIA-364-31 Cycle connectors between 25° ± 3°C at 80% RH and 65 °± 3 °C at 50% RH (24(PL1, PL2) / 50(PL3) cycles). Ramp times should be 0.5 hour and dwell should be 1.0 hour.	Mated	None	
6	Low Level Contact Resistance	EIA 364-23; apply a maximum voltage of 20 mV and a current of 100 mA.	Mated	PL1 – <10 mΩ Δ max PL2 – <10 mΩ Δ max from initial	PL1 – <10 mΩ Δ PL2 – <10 mΩ Δ
7	Reseating	Manually unplug & plug the connector, 3 cycles		No evidence of physical damage	PASS
8	Low Level Contact Resistance	EIA 364-23; apply a maximum voltage of 20 mV and a current of 100 mA.	Mated	PL1 – <10 mΩ Δ max PL2 – <10 mΩ Δ max from initial	PL1 – <10 mΩ Δ PL2 – <10 mΩ Δ

REVISION: B3	ECR/ECN INFORMATION: EC No: UCP2015-0373 DATE: 2014 / 07 / 29	TITLE: PRODUCT SPECIFICATION INTERNAL iPass I/O CONNECTOR & CABLE	SHEET No. 7 of 17
DOCUMENT NUMBER: PS-75783-001	CREATED / REVISED BY: KBINGHAM	CHECKED BY: TMCCLELLAND	APPROVED BY: TMCCLELLAND



PRODUCT SPECIFICATION

6.3 TEST GROUP 3

ITEM	TEST	TEST PROCEDURE	CONDITION	REQUIREMENT	ACTUAL
1	Low Level Contact Resistance	EIA-364-23; apply a maximum voltage of 20 mV and a current of 100 mA.	Mated	PL1 - baseline PL2 - baseline	PL1 - N/A PL2 - N/A
2	Durability (precondition)	EIA-364-09; perform plug & unplug cycles: PL1 (20), PL2 (50), PL3 (50).		No evidence of physical damage	PASS
3	Temperature Life (precondition)	EIA-364-17, method A, Test Condition 3 at 105°±2°C PL1 – 36 hours PL2 – 72 hours PL3 – 150 hours	Mated	None	
4	Low Level Contact Resistance	EIA-364-23; apply a maximum voltage of 20 mV and a current of 100 mA.	Mated	PL1 - <10 mΩ Δ max PL2 - <10 mΩ Δ max from initial	PL1 - <10 mΩ Δ max PL2 - <10 mΩ Δ max
5	Mechanical Vibration	EIA-364-28 test condition VII test condition letter D 15 minutes in each of 3 mutually perpendicular directions. Both mating halves rigidly fixed to not contribute to relative motion of one contact against another.	Mated	Discontinuity < 1 μsec No evidence of physical damage	PASS
6	Low Level Contact Resistance	EIA-364-23; apply a maximum voltage of 20 mV and a current of 100 mA.	Mated	PL1 - <10 mΩ Δ max PL2 - <10 mΩ Δ max from initial	PL1 - <10 mΩ Δ max PL2 - <10 mΩ Δ max

REVISION: B3	ECR/ECN INFORMATION: EC No: UCP2015-0373 DATE: 2014 / 07 / 29	TITLE: PRODUCT SPECIFICATION INTERNAL iPass I/O CONNECTOR & CABLE	SHEET No. 8 of 17
DOCUMENT NUMBER: PS-75783-001	CREATED / REVISED BY: KBINGHAM	CHECKED BY: TMCCLELLAND	APPROVED BY: TMCCLELLAND



PRODUCT SPECIFICATION

6.4 TEST GROUP 7

ITEM	TEST	TEST PROCEDURE	CONDITION	REQUIREMENT	ACTUAL
1	Dielectric Withstanding Voltage	EIA-364-20; apply a voltage of 300 VDC for 1 minute between adjacent terminals and between adjacent terminals and ground.	Mated	No disruptive discharge No leakage current in excess of 5mA	PASS
2	Low Level Contact Resistance	EIA-364-23; apply a maximum voltage of 20 mV and a current of 100 mA.	Mated	PL1 - baseline PL2 - baseline	PL1 - N/A PL2 - N/A PL3 - < xx mΩ
3	Durability	EIA-364-09; perform plug & unplug cycles: PL1 (50), PL2 (250)		No evidence of physical damage	PASS
4	Low Level Contact Resistance	EIA-364-23; apply a maximum voltage of 20 mV and a current of 100 mA.	Mated	PL1 - <10 mΩ Δ max PL2 - <10 mΩ Δ max from initial	PL1 - <10 mΩ Δ max PL2 - <10 mΩ Δ max
5	Dielectric Withstanding Voltage	EIA-364-20; apply a voltage of 300 VDC for 1 minute between adjacent terminals and between adjacent terminals and ground.	Mated	No disruptive discharge No leakage current in excess of 5mA	PASS

Note:

1. Separate sets of test specimens will be used to access dielectric withstanding voltage and the change in low level contact resistance.
2. Dielectric withstanding voltage testing will use different contacts than those used for low level contact resistance testing.

REVISION: B3	ECR/ECN INFORMATION: EC No: UCP2015-0373 DATE: 2014 / 07 / 29	TITLE: PRODUCT SPECIFICATION INTERNAL iPass I/O CONNECTOR & CABLE	SHEET No. 9 of 17
DOCUMENT NUMBER: PS-75783-001	CREATED / REVISED BY: KBINGHAM	CHECKED BY: TMCCLELLAND	APPROVED BY: TMCCLELLAND



PRODUCT SPECIFICATION

6.5 MECHANICAL TEST GROUP 1

ITEM	TEST	TEST PROCEDURE	CONDITION	REQUIREMENT	ACTUAL
1	Temperature Rise (via current cycling)	Measure the temperature rise at the rated current after 96 hours. (45 minutes ON and 15 minutes OFF). Fixture as required.	Mated	Temperature Rise: +30°C maximum	0.3 A min. with < 30°C Temperature Rise

6.6 MECHANICAL TEST GROUP 2

ITEM	TEST	TEST PROCEDURE	CONDITION	REQUIREMENT	ACTUAL
1	Connector Mate Forces (Module only)	Mate connector at a rate of 25 mm per min.	Mate	2.5 N / contact pair MAX insertion force	0.5-0.75 N / contact pair
2	Connector Un-mate Forces (Module only)	Un-mate connector at a rate of 25 mm per min.	Un-mate	0.5 N / contact pair MAX withdrawal force	0.25-0.35 N / contact pair
3	Plug Mate Forces (Active Latch)	Mate connector at a rate of 25 mm per min.	Mate	2.5 N / contact pair MAX insertion force plus 20 N MAX	26 ckt: 9 N – 19 N 36 ckt: 12 N – 25 N 50 ckt: 17 N – 34 N 68 ckt: 22 N – 48 N
4	Plug Un-Mate Forces (Active Latch)	Un-mate connector at a rate of 25 mm per min	Un-mate	0.5 N / contact pair plus 20 N MAX	26 ckt: 6 N – 11 N 36 ckt: 8 N – 15 N 50 ckt: 11 N – 21 N 68 ckt: 15 N – 29 N
5	Plug Mate Forces (Passive Latch)	Mate connector at a rate of 25 mm per min.	Mate	2.5 N / contact pair MAX plus 20 N MAX	26 ckt: 9 N – 19 N 36 ckt: 12 N – 25 N 50 ckt: 17 N – 34 N 68 ckt: 22 N – 48 N
6	Plug Un-Mate Forces (Passive Latch)	Un-mate connector at a rate of 25 mm per min	Un-mate	0.5 N / contact pair plus 20 N MAX	26 ckt: 6 N – 11 N 36 ckt: 8 N – 15 N 50 ckt: 11 N – 21 N 68 ckt: 15 N – 29 N

REVISION: B3	ECR/ECN INFORMATION: EC No: UCP2015-0373 DATE: 2014 / 07 / 29	TITLE: PRODUCT SPECIFICATION INTERNAL iPass I/O CONNECTOR & CABLE	SHEET No. 10 of 17
DOCUMENT NUMBER: PS-75783-001	CREATED / REVISED BY: KBINGHAM	CHECKED BY: TMCLELLAND	APPROVED BY: TMCLELLAND



PRODUCT SPECIFICATION

6.7 MECHANICAL TEST GROUP 3

ITEM	TEST	TEST PROCEDURE	CONDITION	REQUIREMENT	ACTUAL
1	Terminal Retention Force	Axial pullout force on the terminal in the housing at a rate of 25 mm (1 in) per min.		4.5 N MINIMUM retention force	6.2 N MINIMUM
2	Normal Force	Apply a perpendicular force.		0.49 N, (50 grams) MINIMUM normal force	0.49 N, (50 grams) MINIMUM normal force

6.8 MECHANICAL TEST GROUP 4

ITEM	TEST	TEST PROCEDURE	CONDITION	REQUIREMENT	ACTUAL
1	Shell Retention (Side)	Mate plug to connector and load cable toward side.	Mated	30 N MIN	PASS (54 N minimum)
2	Shell Retention (Toward Latch)	Mate plug to connector and load cable toward latch.	Mated	30 N MIN	PASS (72 N minimum)

6.9 MECHANICAL TEST GROUP 5

ITEM	TEST	TEST PROCEDURE	CONDITION	REQUIREMENT	ACTUAL
1	Latitudinal Load	Mate plug to connector and load plug with latitudinal load until open circuit.	Mated	30 N minimum	PASS (30 N minimum)
2	Longitudinal Load	Mate plug to connector and load plug with longitudinal load until open circuit.	Mated	30 N minimum	PASS (50 N minimum top) (40 N minimum top)
3	Cable Pullout Force (Axial)	Mate plug to connector and apply an axial pullout force on the wire at a rate of 25 mm per min.	Mated	50 N minimum	PASS (50 N minimum)
4	Cable Pullout Force (Right Angle)	Mate plug to connector and apply a right angle pullout force on the wire at a rate of 25 mm per min.	Mated	30 N minimum	PASS (30 N minimum)

REVISION: B3	ECR/ECN INFORMATION: EC No: UCP2015-0373 DATE: 2014 / 07 / 29	TITLE: PRODUCT SPECIFICATION INTERNAL iPass I/O CONNECTOR & CABLE	SHEET No. 11 of 17
DOCUMENT NUMBER: PS-75783-001		CREATED / REVISED BY: KBINGHAM	CHECKED BY: TMCLELLAND
		APPROVED BY: TMCLELLAND	



PRODUCT SPECIFICATION

6.10 MECHANICAL TEST GROUP 6

ITEM	TEST	TEST PROCEDURE	CONDITION	REQUIREMENT	ACTUAL
1	Solderability	Per SMES-152		Solder Coverage 95% minimum	PASS
2	SMT Process Compatibility (Pb Free)	See Section 10.0 for Molex Connector Only Test Profile		Dimensional: Conformance to Sales Drawing Requirements Visual: No Damage	No opens No bridges No damage

6.11 MECHANICAL TEST GROUP 7

ITEM	TEST	TEST PROCEDURE	CONDITION	REQUIREMENT	ACTUAL
1	Longitudinal Load (connector only)	Mate connector and load module in peel and shear modes.		Peel: 15 N min Shear: 150 N min	Peel: 20 N min Shear: 180 N min

6.12 MECHANICAL TEST GROUP 8

ITEM	TEST	TEST PROCEDURE	CONDITION	REQUIREMENT	ACTUAL
1	Wire Flex	EIA 364-21 test condition II with Tension = 26 N . Flex cables 180° for 20 cycles..	Mated	No physical damage	PASS

REVISION: B3	ECR/ECN INFORMATION: EC No: UCP2015-0373 DATE: 2014 / 07 / 29	TITLE: PRODUCT SPECIFICATION INTERNAL iPass I/O CONNECTOR & CABLE	SHEET No. 12 of 17
DOCUMENT NUMBER: PS-75783-001	CREATED / REVISED BY: KBINGHAM	CHECKED BY: TMCCLELLAND	APPROVED BY: TMCCLELLAND



PRODUCT SPECIFICATION

7.0 PERFORMANCE (HIGH SPEED CHARACTERIZATION)

7.1 SIGNAL INTEGRITY REQUIREMENTS (CONNECTOR ONLY)

ITEM	DESCRIPTION	TEST CONDITION	REQUIREMENT	ACTUAL
1	Return Loss	Frequency range 50MHz to 7.5GHz Frequency range 7.5GHz to 15GHz • 2.5dB at 15GHz	-10 dB -10 - 25log ₁₀ (f / 7.5GHz) dB	-16 dB -3.8 dB
2	Differential Impedance	Rise-time of 25ps (20-80%)	100 ± 10 ohms	96 – 107 ohms
3	Insertion Loss	Frequency range 50 MHz to 10 GHz	0.13 dB at 1.25 GHz 0.25 dB at 2.50 GHz 0.50 dB at 5.00 GHz	0.10 dB 0.16 dB 0.22 dB
4	Propagation Delay	Frequency range 1GHz to 15 GHz (group delay)	≤ 60 ps	55 ps
5	Crosstalk	NEXT, FEXT for adjacent pairs within a row NEXT, FEXT for adjacent pairs across rows *Measured at 25ps 20-80% rise-time PCIe application specific RMS sum $\sqrt{[Tx_NEXT^2 + 2*(Rx_FEXT)^2]}$ *FEXT is measured at 45ps 20-80% rise-time	≤ 2 % ≤ 2 % ≤ 5 %	0.75%, 1.04% 0.65%, 1.00% 1.65%
6	Isolation	Frequency range 50MHz to 15GHz Measure near-end and far-end isolation - Adjacent pairs within a row - Adjacent pairs across rows	-30 dB	-25 dB @ 9.7GHz -28 dB @ 10.8GHz
7	Differential Skew (Within Pair)	Mate plug to receptacle	<1 ps	<1 ps
8	Data Rate	Mate plug to receptacle, including launches	Average: 10 Gbps	> 15 Gbps

REVISION: B3	ECR/ECN INFORMATION: EC No: UCP2015-0373 DATE: 2014 / 07 / 29	TITLE: PRODUCT SPECIFICATION INTERNAL iPass I/O CONNECTOR & CABLE	SHEET No. 13 of 17
DOCUMENT NUMBER: PS-75783-001	CREATED / REVISED BY: KBINGHAM	CHECKED BY: TMCCLELLAND	APPROVED BY: TMCCLELLAND



PRODUCT SPECIFICATION

7.2 SIGNAL INTEGRITY REQUIREMENTS (CONNECTOR & CABLE SYSTEM)

ITEM	DESCRIPTION	TEST CONDITION	REQUIREMENT	ACTUAL
1	Differential Impedance	Rise time of 55 ps (20 % - 80 %)	100 ± 15 ohms (mated cable)	91-101 ohms
2	Common-mode Impedance	Rise time of 55 ps (20 % - 80 %)	32.5 ± 7.5 ohms (cable)	26-37 ohms
3	Differential Mode Return Loss	- Measured from 10 MHz < f < 4.5 GHz - Measured from 4.5 GHz < f < 6.5 GHz	≤ -8 dB ≤ -8+16 dB per decade	≤ -xx dB ≤ -xx dB
4	Common Mode Return Loss	Measured from 10 MHz to 6.5 GHz	≤ -8 dB	≤ -xx dB
5	Differential to Common Mode Conversion	- SCD22: 10 MHz < f < 9.0 GHz - SCD22: 10 MHz < f < 9.0 GHz	≤ -26 dB ≤ -20 dB	≤ -xx dB ≤ -xx dB
6	Differential Insertion Loss	Measured from 10 MHz to 3.0 GHz	≤ -1.25-(f/250) dB	≤ -xx dB (10 m, 24 AWG)
7	Multi-Lane Isolation	- Measured from 10 MHz to 4.5 GHz - (4) near-end aggressor pairs and (1) victim pair - TotalNEXT(f) = 10 × log ∑ ₁ ⁴ 10 ^{(NEXT(f)/10)}	≤ -26 dB	≤ -40 dB @ 4.5 GHz (10 m, 24 AWG)

REVISION: B3	ECR/ECN INFORMATION: EC No: UCP2015-0373 DATE: 2014 / 07 / 29	TITLE: PRODUCT SPECIFICATION INTERNAL iPass I/O CONNECTOR & CABLE	SHEET No. 14 of 17
DOCUMENT NUMBER: PS-75783-001	CREATED / REVISED BY: KBINGHAM	CHECKED BY: TMCCLELLAND	APPROVED BY: TMCCLELLAND



PRODUCT SPECIFICATION

8.0 PACKAGING

8.1 CONNECTOR AND SHELL

- 8.1.1 Product shall be packaged in tape and reel per the packaging specification as called out on the applicable assembly print.
- 8.1.2 Packaging shall meet the requirements of and be tested per the packaging specification as called out on the applicable assembly print.

8.2 PLUG AND CABLE ASSEMBLY

- 8.2.1 Connector shall be packaged in tape and reel per the packaging specification as called out on the applicable assembly print.
- 8.2.2 Shells shall be packaged in trays per the packaging specification as called out on the applicable assembly print.
- 8.2.3 Packaging shall meet the requirements of and be tested per the packaging specification as called out on the applicable assembly print.

8.3 PLUG AND CABLE ASSEMBLY

- 8.3.1 Product shall be packaged to protect against damage during handling, transit and storage.

REVISION: B3	ECR/ECN INFORMATION: EC No: UCP2015-0373 DATE: 2014 / 07 / 29	TITLE: PRODUCT SPECIFICATION INTERNAL iPass I/O CONNECTOR & CABLE	SHEET No. 15 of 17
DOCUMENT NUMBER: PS-75783-001	CREATED / REVISED BY: KBINGHAM	CHECKED BY: TMCCLELLAND	APPROVED BY: TMCCLELLAND



PRODUCT SPECIFICATION

9.0 GAGES AND FIXTURES

Test setup for latitudinal and longitudinal load testing and shell retention testing. Probe is about 6mm in diameter with a full radius nose. The probe is to be placed 20mm from the front edge of the receptacle and located at the centerline of the plug. Apply load to plug at a rate of 25mm per minute.

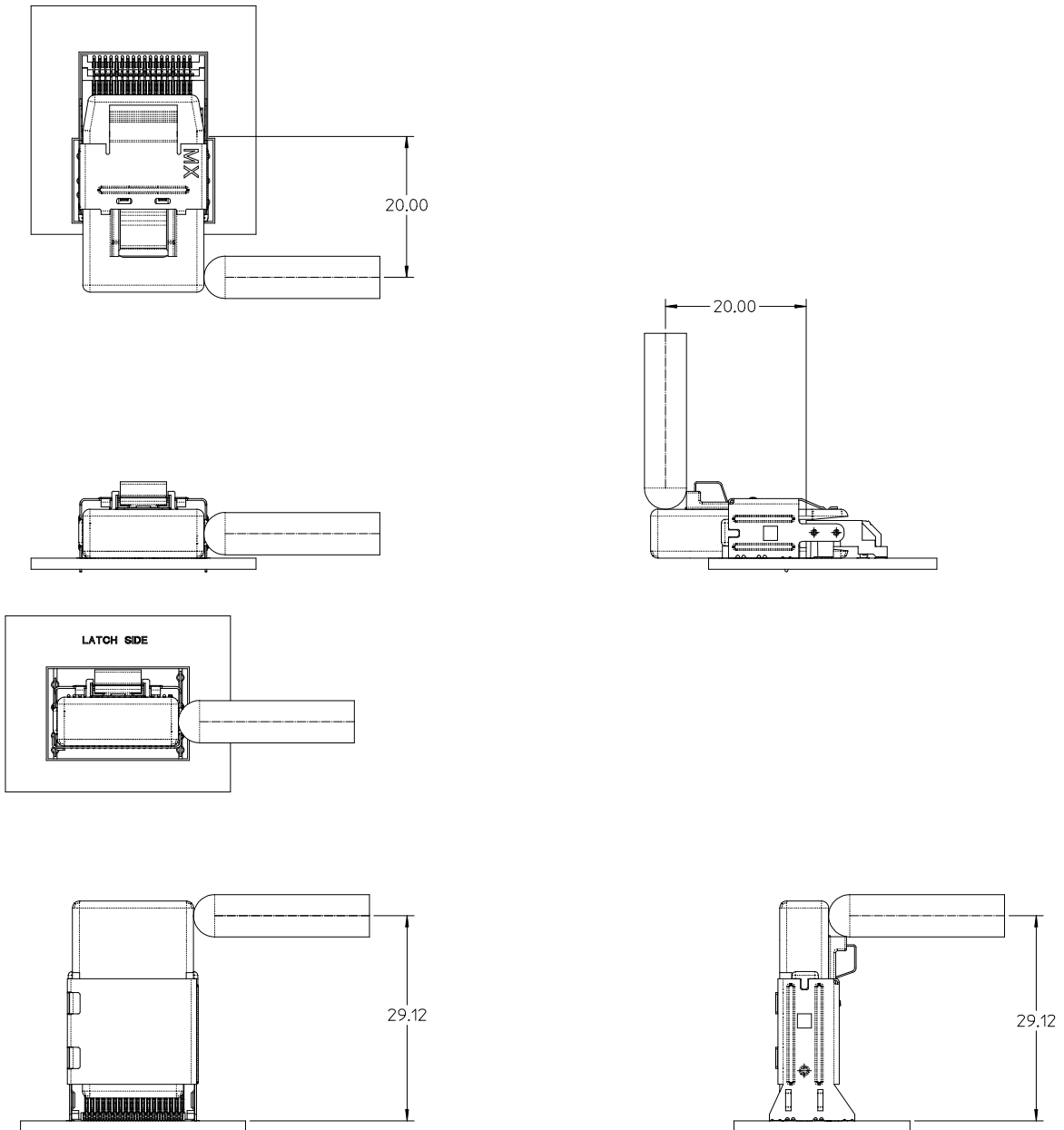

REVISION: B3	ECR/ECN INFORMATION: EC No: UCP2015-0373 DATE: 2014 / 07 / 29	TITLE: PRODUCT SPECIFICATION INTERNAL iPass I/O CONNECTOR & CABLE	SHEET No. 16 of 17
DOCUMENT NUMBER: PS-75783-001	CREATED / REVISED BY: KBINGHAM	CHECKED BY: TMCLELLAND	APPROVED BY: TMCLELLAND



PRODUCT SPECIFICATION

10.0 OTHER INFORMATION

10.1 MOLEX CONNECTOR ONLY TEST PROFILE

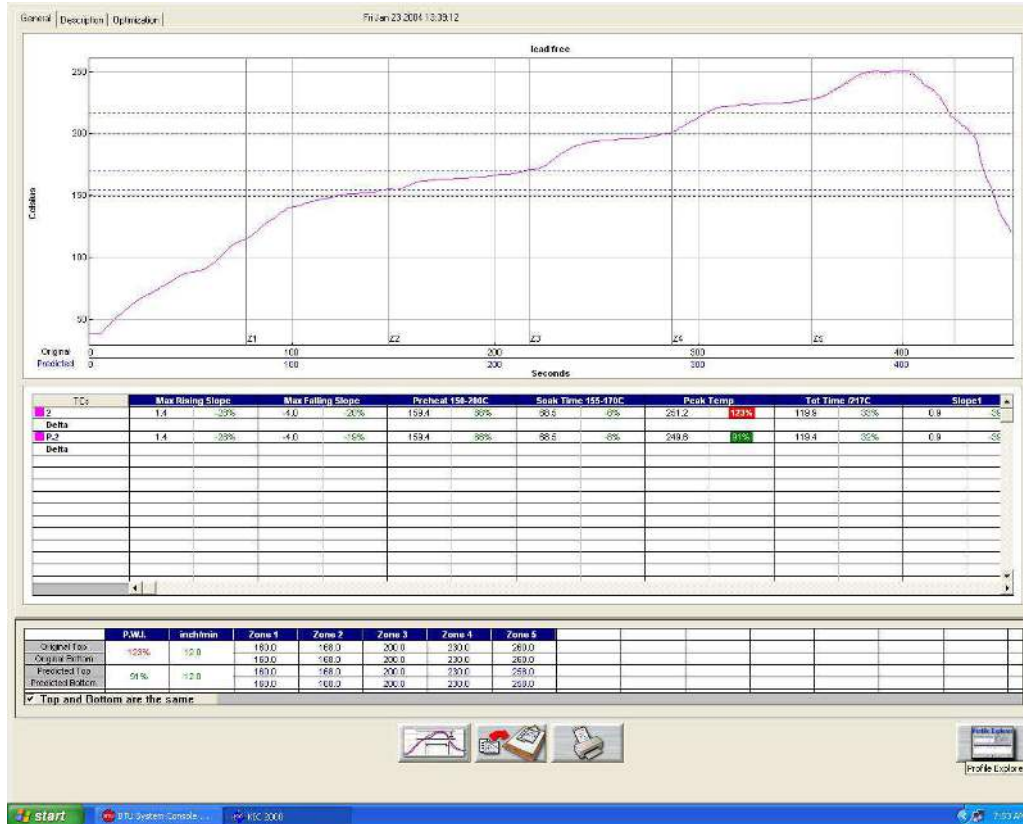

SMT Profile

Ramp-Up:	Average Rate of 3° C/second max
Preheat Temperature:	150° C min. to 200° C max. for 60-180 seconds
Time maintained above:	217° C for 60-120 seconds
Peak Temperature:	250° C
Time within 5° C of actual Peak Temperature:	20-40 seconds
Ramp-Down:	Average Rate of 6° C/second max
Cycle Duration, 25° C to Peak Temperature:	8 minutes maximum

10.2 INVERTED SMT APPLICATION

See AS-75586-001 Application Specification for inverted SMT application. Glue must be used on the locating pegs to hold the part while inverted through the reflow process.

REVISION: B3	ECR/ECN INFORMATION: EC No: UCP2015-0373 DATE: 2014 / 07 / 29	TITLE: PRODUCT SPECIFICATION INTERNAL iPass I/O CONNECTOR & CABLE	SHEET No. 17 of 17
DOCUMENT NUMBER: PS-75783-001	CREATED / REVISED BY: KBINGHAM	CHECKED BY: TMCCLELLAND	APPROVED BY: TMCCLELLAND