

MATERIAL

Polyamide based (PA) technopolymer, black or red colour, glossy finish (HGFT/SL only black colour).

WINDOW

Transparent polyamide based (PA-T/AR) technopolymer.

PACKING RING

NBR synthetic rubber.

STANDARD EXECUTIONS

- **HGFT.:** with matte anodised aluminium star-shaped contrast screen with red central level point.
- **HGFT/SL:** without contrast screen.

MAXIMUM CONTINUOUS WORKING TEMPERATURE

100°C at 3 bar pressure.

NOTE

For use with other fluids with special additives, please contact ELESA Sales Department.

ACCESSORIES ON REQUEST

Brass nut type GH. (see page 1746) for fitting to reservoirs with wall thickness smaller than 5 mm.



ELESA Original design

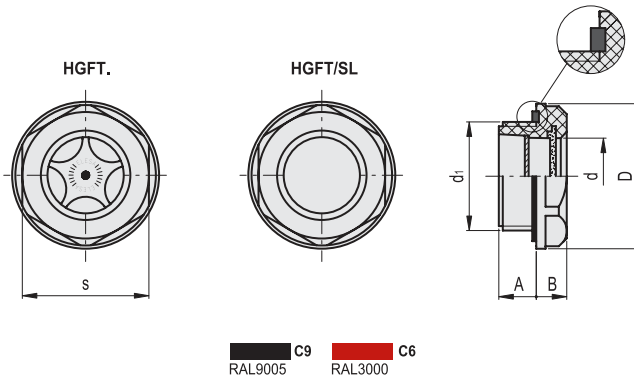

■ C9 RAL9005 ■ C6 RAL3000

HGFT.

BSP

METRIC

| Code | Description | Code | Description | d1 | A | B | D | d | s | Tightening torque [Nm] | ⚖️ |
|-------|----------------|-------|----------------|--------|-----|-----|------|------|----|------------------------|----|
| 14441 | HGFT.10-3/8 C9 | 14444 | HGFT.10-3/8 C6 | G 3/8 | 8 | 7 | 24 | 11 | 22 | 4+8 | 4 |
| 14461 | HGFT.13-1/2 C9 | 14464 | HGFT.13-1/2 C6 | G 1/2 | 10 | 8.5 | 28 | 14.5 | 24 | 6+8 | 6 |
| 14481 | HGFT.16-3/4 C9 | 14484 | HGFT.16-3/4 C6 | G 3/4 | 9.5 | 8.5 | 35 | 18 | 32 | 8+10 | 10 |
| 14521 | HGFT.21-1 C9 | 14524 | HGFT.21-1 C6 | G 1 | 11 | 9.5 | 42.5 | 23 | 38 | 10+12 | 15 |
| 14541 | HGFT.25-1¼ C9 | 14544 | HGFT.25-1¼ C6 | G1 1/4 | 11 | 9 | 50 | 30 | 46 | 12+15 | 30 |
| 14561 | HGFT.40-2 C9 | 14564 | HGFT.40-2 C6 | G 2 | 12 | 11 | 68 | 40 | 62 | 12+15 | 60 |

HGFT/SL

BSP

METRIC

| Code | Description | d1 | A | B | D | d | s | Tightening torque [Nm] | ⚖️ |
|-------|----------------|--------|-----|-----|------|------|----|------------------------|----|
| 14446 | HGFT.10/SL-3/8 | G 3/8 | 8 | 7 | 24 | 11 | 22 | 4+8 | 3 |
| 14466 | HGFT.13/SL-1/2 | G 1/2 | 10 | 8.5 | 28 | 14.5 | 24 | 6+8 | 5 |
| 14486 | HGFT.16/SL-3/4 | G 3/4 | 9.5 | 8.5 | 35 | 18 | 32 | 8+10 | 9 |
| 14526 | HGFT.21/SL-1 | G 1 | 11 | 9.5 | 42.5 | 23 | 38 | 10+12 | 14 |
| 14546 | HGFT.25/SL-1¼ | G1 1/4 | 11 | 9 | 50 | 30 | 46 | 12+15 | 29 |
| 14566 | HGFT.40/SL-2 | G 2 | 12 | 11 | 68 | 40 | 62 | 12+15 | 59 |

- 1
- 2
- 3
- 4
- 5
- 6
- 7
- 8
- 9
- 10
- 11
- 12
- 13
- 14
- 15
- 16
- 17
- 18

Accessories for hydraulic systems