



P	LTR	DESCRIPTION	DATE	DWN	APVD
J1		REDRAWN PER ECR 10-010105	28JUN10	JR	TM
J2		REVISED PER ECO-20-010511	28JUL2020	SG	DR

 E13288 Listed	 LR7189 Certified
16-14 AWG SOLID OR STRANDED	16-14 AWG SOLID OR STRANDED

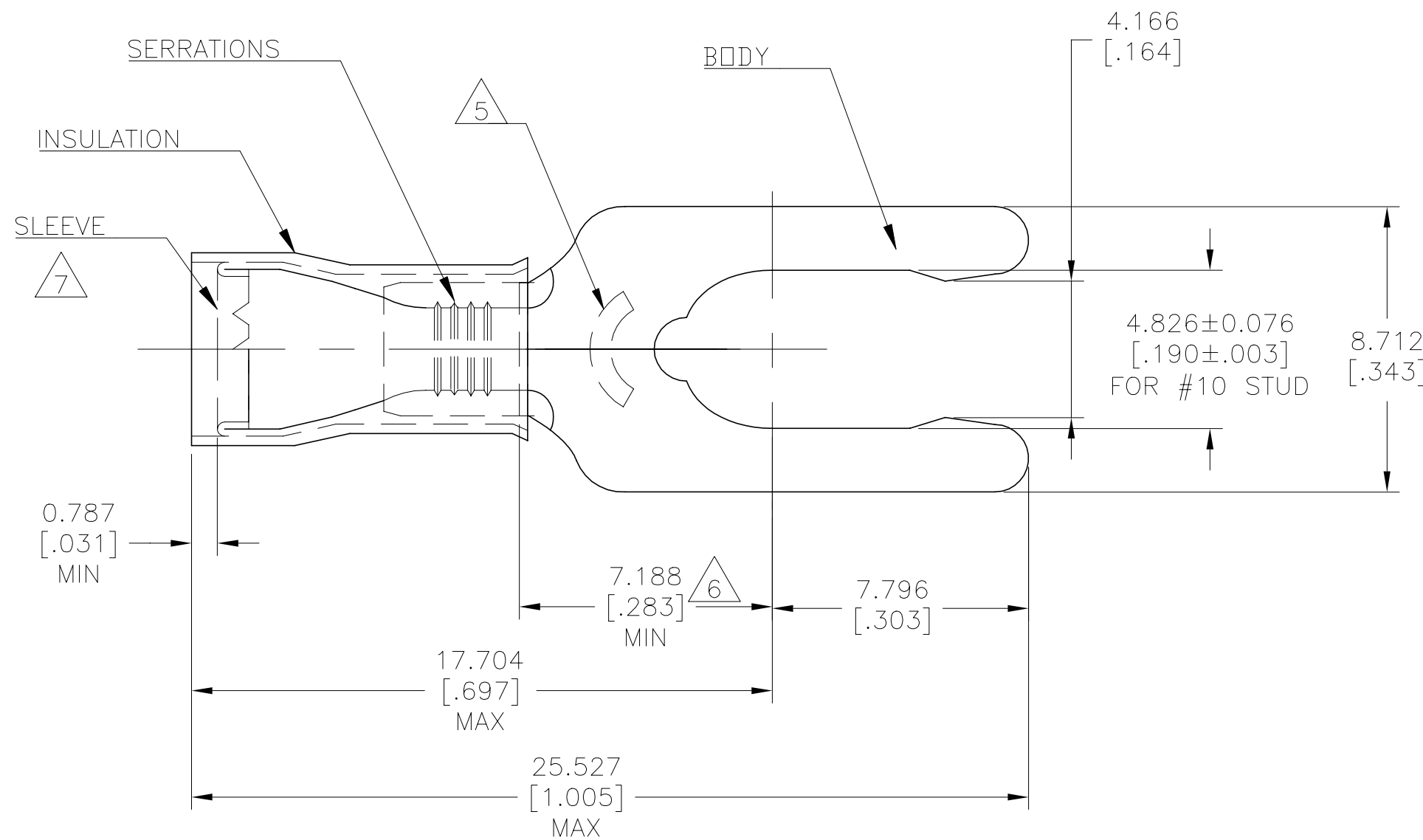

- 1 WIRE INSULATION DIA, SEE TABLE "A"
- 2 BODY MATL THK, 0.789±0.051[.031±.002].
- 3 MATERIAL:
BODY - PHOS BRONZE PER ASTM B103
INSULATION: NYLON PER ASTM D4066
SLEEVE: COPPER PER ASTM B152
- 4 FINISH: BODY & SLEEVE - TIN PLATE
0.00254[.000100] MIN EXT THK PER ASTM B545
INSULATION COLOR - BLUE
- 5 STAMP 10S AMP 16 - 14* APPROX AS SHOWN
- 6 APPLIES FROM EDGE OF METAL WIRE BARREL TO
CENTER OF STUD HOLE
- 7 INTERNAL EDGE FEATURE MAY BE SOLID OR
SCALLOPED

2.921-2.972 [.115-.170]	5000	ON TAPE	52422-3
2.921-2.972 [.115-.170]	1000	LOOSE PIECE	52422-1
DIM "A"	QTY	PACKAGE TYPE	PART NO

AMP INCORPORATED
CUSTOMER SERVICE SYSTEMS

FOR ADDITIONAL PRODUCT INFORMATION OR COPIES OF DRAWINGS AND TECHNICAL DOCUMENTS	PRODUCT INFORMATION CENTER 1-800-522-6752
FOR APPLICATION TOOLING INFORMATION	TOOLING ASSISTANCE CENTER 1-800-722-1111
FOR ORDER ENTRY	1-800-526-5142

MAX RECOMMENDED OPERATING TEMPERATURE: 105C [221°F] MAX
VOLTAGE RATING: 300 VOLT MAX
WIRE CROSS SECTIONAL AREA RANGE, 1.02-2.62mm ² [2,050-5,180] SOLID OR STRANDED

THIS DRAWING IS A CONTROLLED DOCUMENT.

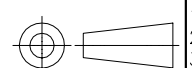
DIMENSIONS: MMmm [INCHES]	TOLERANCES UNLESS OTHERWISE SPECIFIED:
	0 PLC ± - 1 PLC ± - 2 PLC ± 0.127 [.008] 3 PLC ± - 4 PLC ± - ANGLES ± 5°
MATERIAL	FINISH
3	4

DWN	28JUN10
CHK	jr ruth
APVD	14MAY10
PRODUCT SPEC	TOM MICHIELUTTI
APPLICATION SPEC	TOM MICHIELUTTI
WEIGHT	UL486 A-B
	114-2157
CUSTOMER DRAWING	



NAME			
TERMINAL, PIDG, SPRING SPADE, WIRE SIZE: 16-14 AWG			
SIZE	CAGE CODE	DRAWING NO	RESTRICTED TO
A3	00779	C-52422	-
SCALE		SHEET	REV
6:1		1 OF 1	J2