

P	LTR	DESCRIPTION	DATE	DWN	APVD
Z1		NOTE 5 ADDED TO DRAWING	06APR2021	KJK	PS

SEC. A-A

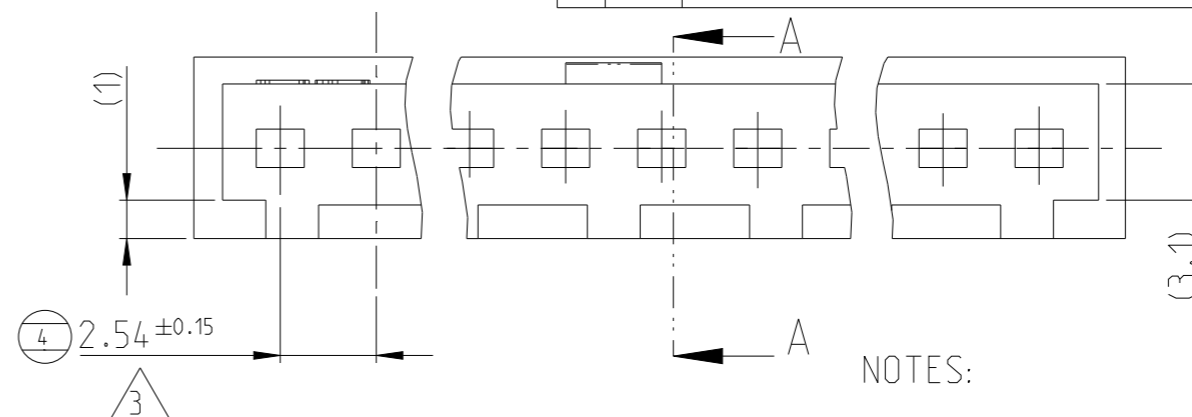

- NOTES:
- ① LCP, BLACK, UL94V-0
 - ② NORYL SE-1 RED COLOUR
 - ③ NON CUMULATIVE TOLERANCE
 - ④ PERMITTED FLASH 0.25mm MAX
 - ⑤ OPTIONAL RIBS EQUALLY SPACED

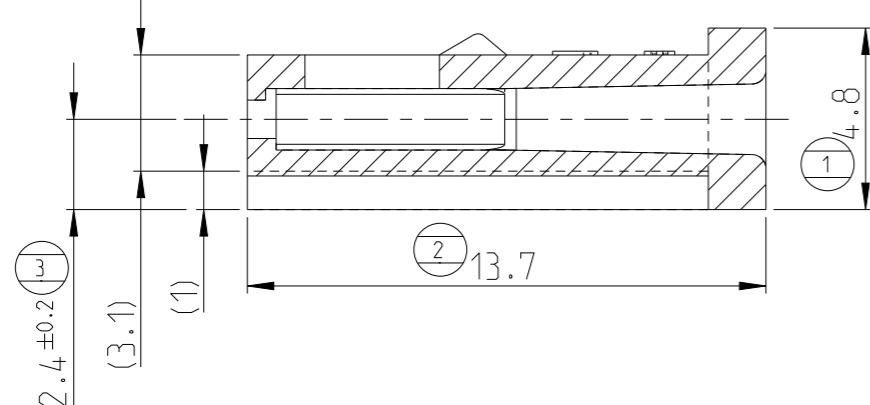
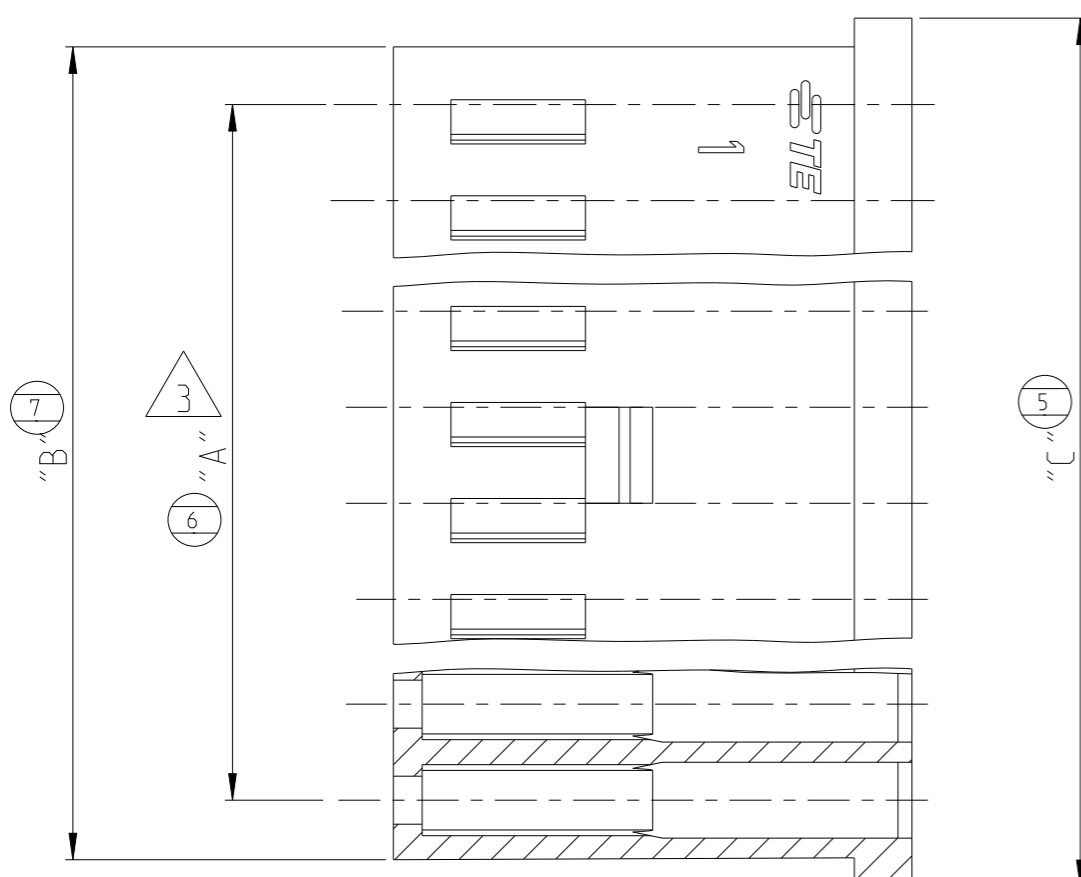

NUM OF POS.	PART NUMBER	DIM "A"	DIM "B"	DIM "C"	MATERIAL (SEE NOTE)
4	1-280359-0	7.62	10.6	12.2	①
2	1-280358-0	2.54	5.6	7.1	
22	280364	53.34	56.4	57.9	
15	280363	35.56	38.6	40.1	
12	280514	27.94	31.0	32.5	
10	280362	22.86	25.9	27.4	
9	280512	20.32	23.3	24.9	
8	280361	17.78	20.8	22.3	
6	280360	12.70	15.7	17.3	
4	280359	7.62	10.6	12.2	
2	280358	2.54	5.6	7.1	
OBSOLETE					②

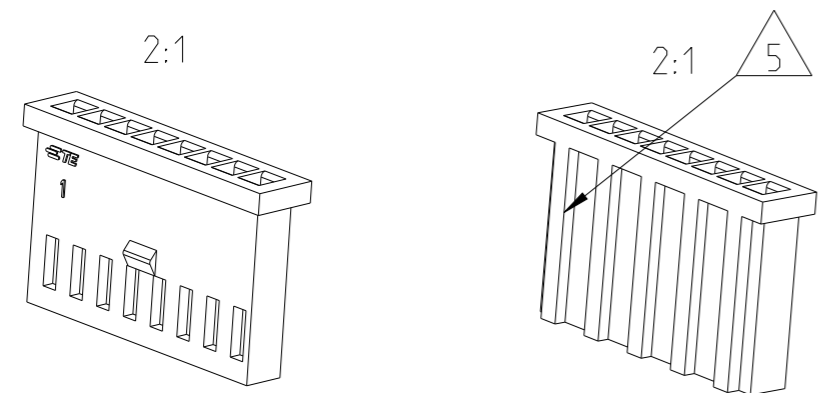

THIS DRAWING IS A CONTROLLED DOCUMENT.

DWN: KARTHIK J K 20MAR2018
 CHK: SHARATH S 15OCT2018
 APVD: PRASHANTH S 15OCT2018

NAME: AMPMODU II REC. HSG SINGLE ROW, CRIMP ON- SNAP IN

PRODUCT SPEC: 108-20025
 APPLICATION SPEC: 114-20004

SIZE: A3 CAGE CODE: 00779 DRAWING NO: C-280358 RESTRICTED TO: -

WEIGHT: -

CUSTOMER DRAWING SCALE: 5:1 SHEET: 1 OF 1 REV: Z1