

THIS DRAWING IS UNPUBLISHED. RELEASED FOR PUBLICATION
 © COPYRIGHT BY TYCO ELECTRONICS CORPORATION. ALL RIGHTS RESERVED.

LOC	DIST	REVISIONS			
P	LTR	DESCRIPTION	DATE	DWN	APVD
AD	00	A	EC 0G3C-0403-03	18AUG04	BSV MZ

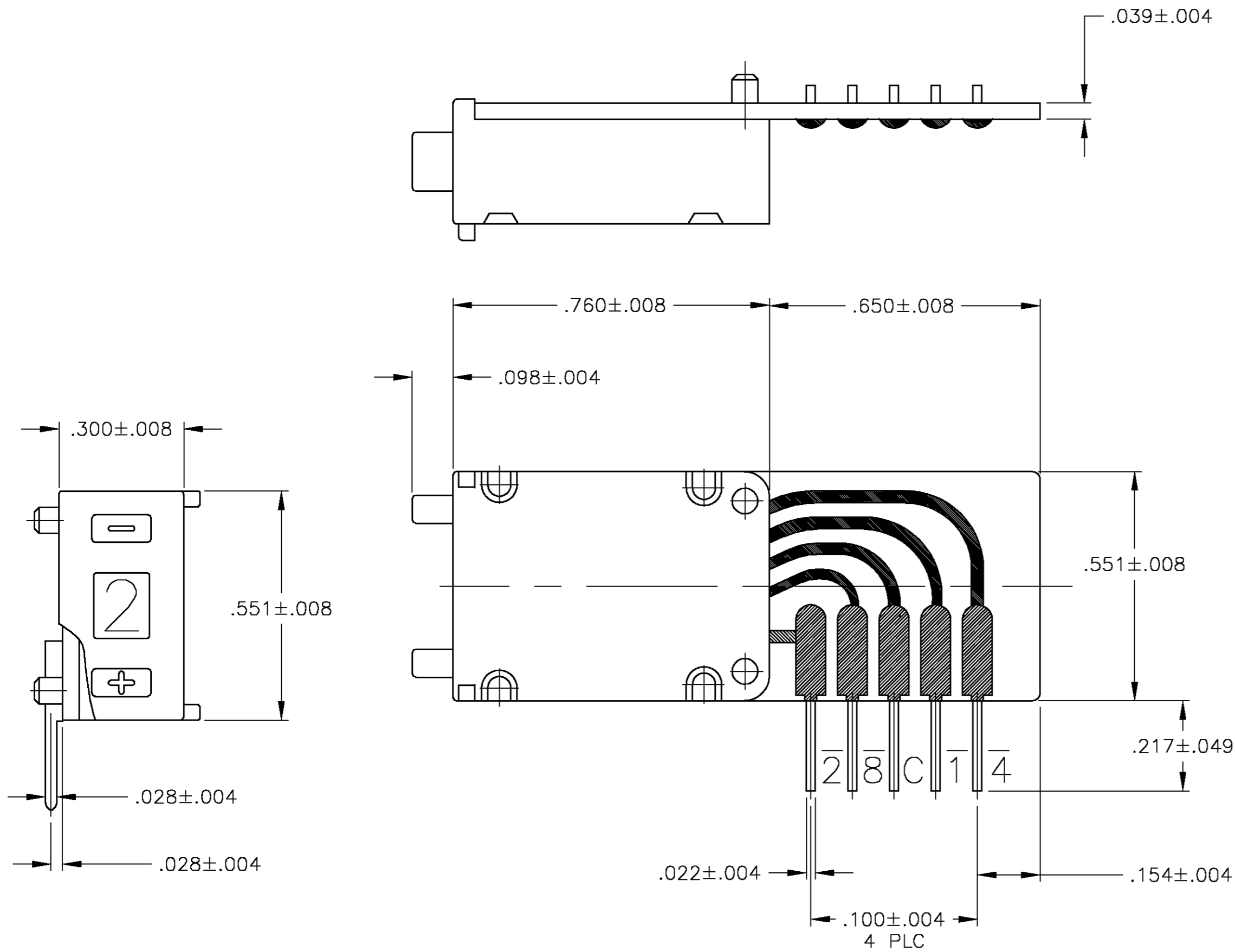

Technical Data

Mechanical	
Permissible ambient temperature	-20°C to +60°C
Expected life (switching cycles)	> 10 ⁵
Actuating force approx.	3N (305g)
Weight approx.	2g
Character height	.122" (10 Position), .094" (16 Position)
Click action	yes
Vibration	DIN EN 60068-2-6
Shock	DIN EN 60068-2-27

Electrical	
Operating voltage	max. 40V
Contact load, static	max. 0.5A
Contact load, dynamic (resistive)	max. 100mA
Contact resistance (measured from the supply line to the output)	< 100mOhm

Material	
Housing & Buttons	PPO, Black
PC board base material	FR4
Contact surface	Au over Ni on Cu
Sliding contact	Au over Ni on CuSn6

10 POSITION BCD COMPLEMENT					
Pin connection					
	c	1	2	4	8
0	●	●	●	●	●
1	●		●	●	●
2	●	●		●	●
3	●			●	●
4	●	●	●		●
5	●		●		●
6	●	●			●
7	●				●
8	●	●	●	●	
9	●		●	●	

PICORD137ALULS
 3-1437601-2

THIS DRAWING IS A CONTROLLED DOCUMENT.		DWN BSV	18AUG04	Tyco Electronics Corporation Harrisburg, Pa 17105-3608	
DIMENSIONS: INCHES	TOLERANCES UNLESS OTHERWISE SPECIFIED:	CHK -	APVD M ZITTO	NAME SWITCH, PUSHWHEEL, PICORDXXXALUS	
	0 PLC ± -	APVD -	PRODUCT SPEC -	SIZE A2	CAGE CODE 00779
	1 PLC ± -	APPLICATION SPEC -	WEIGHT -	DRAWING NO C=3-1437601-2	RESTRICTED TO -
MATERIAL SEE TABLE	FINISH -	SCALE 4:1	SHEET 1 OF 1	REV A	