

PLCC4 Surface Mount LED with Dome Lens



OVSA1xBLCR8 Series

Features:

- High intensity with low power consumption
- PLCC4 packaged in 8 mm tape on 7" diameter reel
- Compatible with automatic placement equipment
- Dimensions: 3.2 x 2.7 x 1.95 mm
- 60° viewing angle



Description:

The OVSA1xBLCR8 series is designed for focused, uniform light output. Its internal reflector and colorless clear lens optimize luminous intensity and make it ideal for backlighting applications and for coupling with light guides.

Applications:

- Traffic lights
- Signal and symbol luminaire
- Mono-color indicators
- Backlighting (LCD, switches, displays, illuminated advertising)
- Interior automotive lighting (instrumentation clusters)
- Safety marker lights (steps, exit ways)

Part Number	Material	Emitted Color	Intensity Typ. mcd	Lens Color
OVSA1ABLCR8	AllnGaP	Amber	5000	Water Clear
OVSA1SBLCR8	AllnGaP	Red	3700	Water Clear

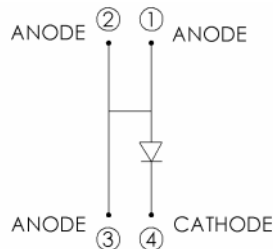
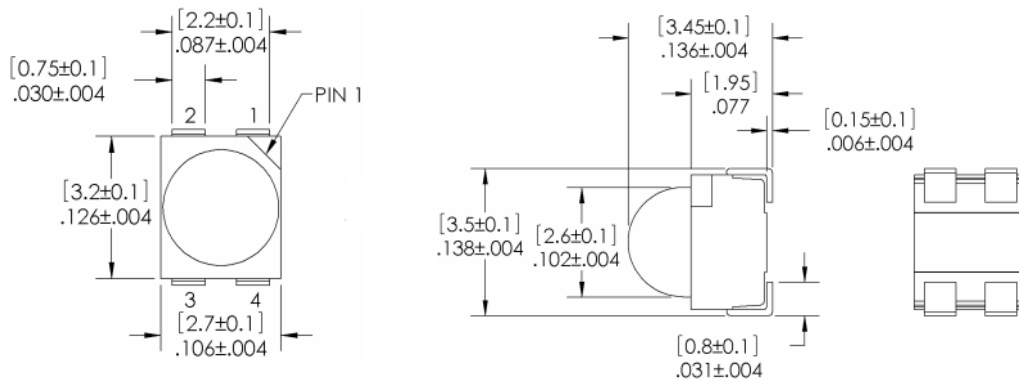

DIMENSIONS ARE IN INCHES AND [MM]

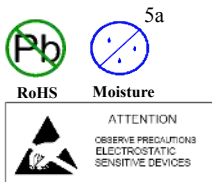

DO NOT LOOK DIRECTLY AT LED WITH UNSHIELDED EYES OR DAMAGE TO RETINA MAY

General Note

TT Electronics reserves the right to make changes in product specification without notice or liability. All information is subject to TT Electronics' own data and is considered accurate at time of going to print.

TT Electronics | Optek Technology, Inc.
1645 Wallace Drive, Ste. 130, Carrollton, TX USA 75006 | Ph: +1 972 323 2200
www.ttelectronics.com | sensors@ttelectronics.com

PLCC4 Surface Mount LED with Dome Lens

OVSA1xBLCR8 Series



Electrical Specifications

Absolute Maximum Ratings (T _A = 25° C unless otherwise noted)	
Storage Temperature Range	-40 ~ +100 °C
Operating Temperature Range	-40 ~ +100 °C
Reverse Voltage	5 V
Continuous Forward Current	70 mA
Peak Forward Current (Pulse width ≤10 msec, duty cycle ≤10%)	200 mA
Power Dissipation	210 mW
Thermal Resistance Junction to Solder ¹	150° C/W
Electrostatic Discharge Classification (MIL-STD-883E)	Class 2
LED Junction Temperature	110° C
Lead Soldering Temperature	250° C / 10 seconds

Note:

1. Rth test condition: Mounted on PC board FR 4 (pad size ≥16 mm²)

Electrical Characteristics (T _A = 25° C unless otherwise noted)							
SYMBOL	PARAMETER	MIN	TYP	MAX	UNITS	TEST CONDITIONS	
I _v	Luminous Intensity	Red	2240	3700		mcd	I _F = 50 mA
V _F	Forward Voltage	Forward Voltage	----	2.5	3.0	V	I _F = 50 mA
I _R	Reverse Current	Reverse Current	----	----	10	μA	V _R = 5 V
λ _D	Dominant Wavelength	Red	618	624	630	nm	I _F = 50 mA
2Θ _{½H-H}	50% Power Angle	50% Power Angle		60		deg	I _F = 50 mA

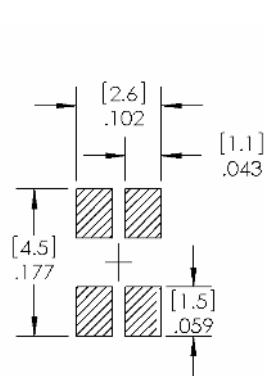

RECOMMENDED SOLDER PASTE PATTERN

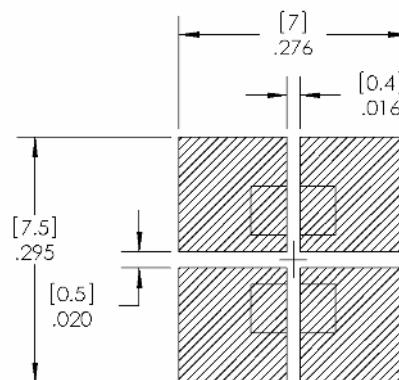

RECOMMENDED COPPER PATTERN

General Note

TT Electronics reserves the right to make changes in product specification without notice or liability. All information is subject to TT Electronics' own data and is considered accurate at time of going to print.

TT Electronics | Optek Technology, Inc.
1645 Wallace Drive, Ste. 130, Carrollton, TX USA 75006 | Ph: +1 972 323 2200
www.ttelectronics.com | sensors@ttelectronics.com

PLCC4 Surface Mount LED with Dome Lens



OVSA1xBLCR8 Series

Standard Bins

LEDs are sorted to luminous intensity (I_V) and dominant wavelength (nm) bins listed below. Each reel consists of a single intensity bin and a single color bin. Orders are filled using all intensity and color bins listed in the following tables. Optek will not accept orders for single intensity bins or single color bins.

Luminous Intensity (I_V) @ 50mA

RED: OVSA1SBLCR8		
IV Code	Min (mcd)	Max (mcd)
Xb	2240	2800
Ya	2800	3550
Yb	3550	4500
Z0	4500	5600

Dominant Wavelength (nm)

RED: OVSA1SBLCR8		
nm Code	Min	Max
RA	618	630

AMBER: OVSA1ABLCR8		
IV Code	Min (mcd)	Max (mcd)
Yb	3550	4500
Z0	4500	5600
A0	5600	7100
B0	7100	9000

AMBER: OVSA1ABLCR8		
nm Code	Min	Max
A2	584	587
A3	587	590
A4	590	593
A5	593	596
A6	596	599

Reflow Solder Profile

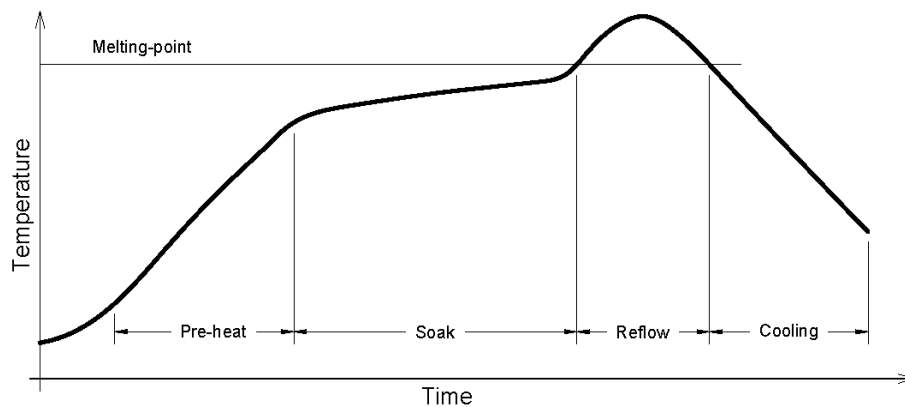

Solder = Lead-Free	
Average ramp-up rate = 4°C / sec. max	Peak temperature = 250°C max.
Preheat temperature: 150 - 220°C	Time within 5°C of actual peak temperature = 10 sec. max
Preheat time: 120 sec. max.	
Ramp-down rate = 6°C / sec. max.	Duration above 217°C is 60 sec. max

General Note

TT Electronics reserves the right to make changes in product specification without notice or liability. All information is subject to TT Electronics' own data and is considered accurate at time of going to print.

TT Electronics | Optek Technology, Inc.
 1645 Wallace Drive, Ste. 130, Carrollton, TX USA 75006 | Ph: +1 972 323 2200
www.ttelectronics.com | sensors@ttelectronics.com

PLCC4 Surface Mount LED with Dome Lens



OVSA1xBLCR8 Series

Typical Electro-Optical Characteristics Curves for OVSA1SBLCR8 (Red) & OVSA1ABLCR8 (Amber)

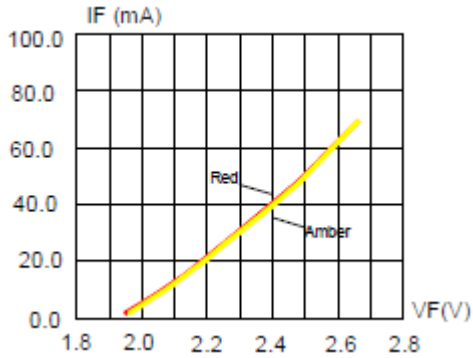

Forward Current vs. Forward Voltage

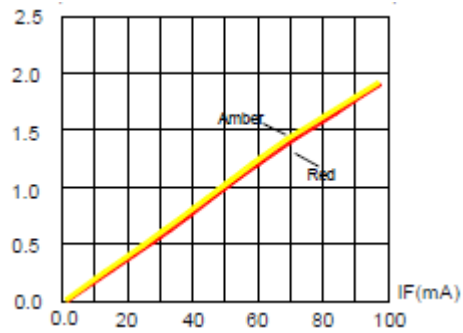

Relative Luminous Intensity vs. Forward Current

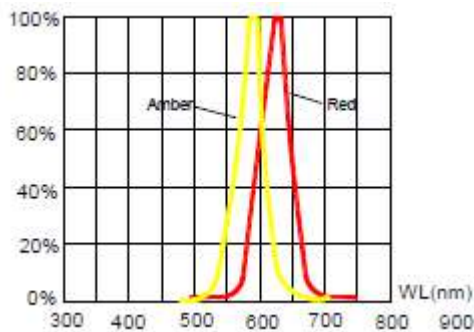

Relative Luminous Intensity vs. Wavelength

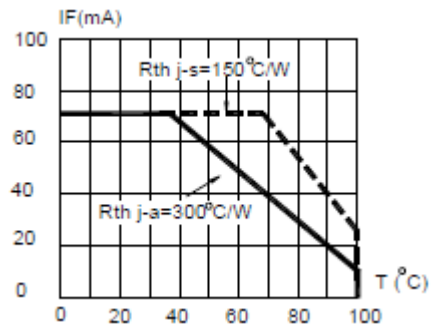

Red & Amber Maximum Forward DC Current vs. Ambient

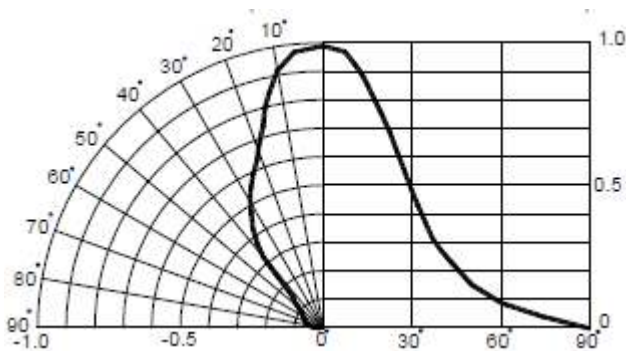

Angular Distribution

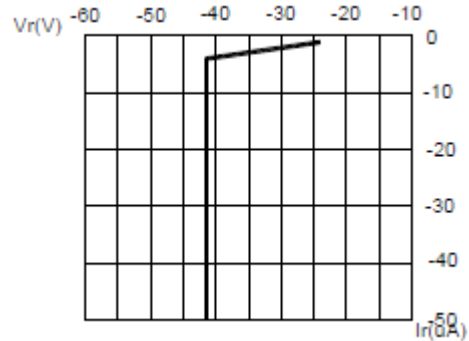

Red & Amber Reverse Current vs. Reverse Voltage

General Note
TT Electronics reserves the right to make changes in product specification without notice or liability. All information is subject to TT Electronics' own data and is considered accurate at time of going to print.

TT Electronics | Optek Technology, Inc.
1645 Wallace Drive, Ste. 130, Carrollton, TX USA 75006 | Ph: +1 972 323 2200
www.ttelectronics.com | sensors@ttelectronics.com

PLCC4 Surface Mount LED with Dome Lens



OVSA1xBLCR8 Series

Reel Dimensions: 7-inch reel

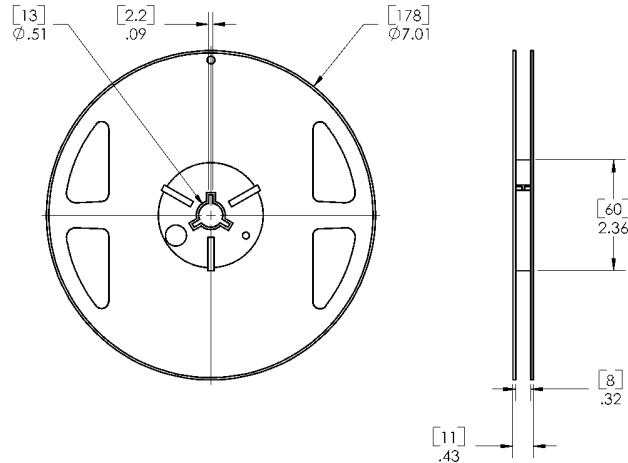

Carrier Tape Dimensions: Loaded Quantity 700 pieces per reel

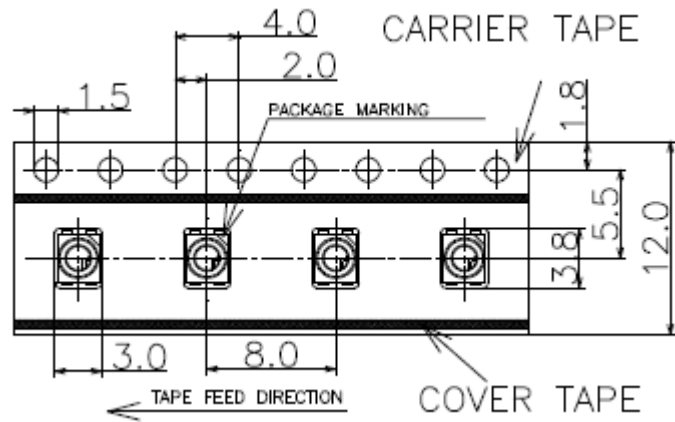

Moisture Resistant Packaging:

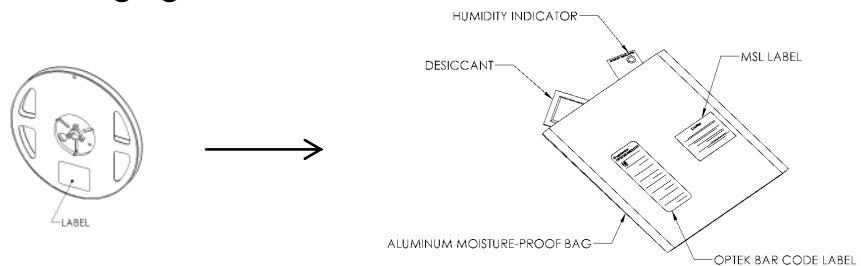

General Note
TT Electronics reserves the right to make changes in product specification without notice or liability. All information is subject to TT Electronics' own data and is considered accurate at time of going to print.

TT Electronics | Optek Technology, Inc.
1645 Wallace Drive, Ste. 130, Carrollton, TX USA 75006 | Ph: +1 972 323 2200
www.ttelectronics.com | sensors@ttelectronics.com