

TRIO-PS-2G/1AC/12DC/5/C2LPS

Power supply unit

Data sheet
106963_en_00

© PHOENIX CONTACT 2017-07-27



1 Description

TRIO POWER - power supplies with standard functionality
The power supplies of the TRIO POWER family convince due to their slim and robust design. The dynamic boost (1.5 x I_N for 5 seconds) absorbs starting currents and short overload situations securely during operation and without a drop in output voltage. The push-in connection technology on the front enables fast and tool-free wiring of the devices.

Features

- Tool-free connection via push-in connection technology
- Safe operation, thanks to electrically and mechanically robust design
- Especially slim design
- Worldwide use, thanks to wide-range input
- Reliable starting of heavy loads, thanks to dynamic boost (1.5 x I_N for 5 seconds)
- Simplified error diagnostics for remote signaling via DC-OK signal contact
- OVP (Over Voltage Protection) limits surge voltages to ≤25 V DC

Technical data (short form)

Input voltage range	100 V AC ... 240 V AC -15 % ... +10 % 110 V DC ... 250 V DC ±10 %
Mains buffering	> 20 ms (120 V AC) > 110 ms (230 V AC)
Nominal output voltage (U _N)	12 V DC ±1 %
Setting range of the output voltage (U _{Set})	12 V DC ... 18 V DC
Nominal output current (I _N)	5 A
Output power (P _N) Output power (P _{Dyn. Boost})	60 W 90 W
Efficiency	typ. 85 % (120 V AC) typ. 85.6 % (230 V AC)
Residual ripple	< 50 mV _{pp}
MTBF (IEC 61709, SN 29500)	> 5800000 h (25 °C) > 2900000 h (40 °C) > 1500000 h (60 °C)
Ambient temperature (operation)	-25 °C ... 70 °C > 60 °C Derating: 2.5 %/K
Dimensions W/H/D	30 mm / 130 mm / 115 mm
Weight	0.32 kg
Approved according to	NEC Class 2 (UL 1310)



Make sure you always use the latest documentation.
It can be downloaded from the product at phoenixcontact.net/products.

2 Table of contents

1	Description	1
2	Table of contents	2
3	Ordering data	4
4	Technical data	5
5	Safety regulations and installation notes	11
6	High-voltage test (HIPOT)	12
6.1	High-voltage dielectric test (dielectric strength test) and why must it be performed?	12
6.2	High-voltage dielectric test during the manufacturing process	12
6.3	High-voltage dielectric test performed by the customer	12
6.4	Performing high-voltage testing	12
7	Basic circuit diagram	13
8	Structure	13
9	Cooling	14
10	Mounting position and dimensions	14
10.1	Mounting position	14
10.2	Device dimensions	15
11	Mounting/removal	16
11.1	Assembly	16
11.2	Removal	16
12	Device connection terminal blocks	16
12.1	Push-in connection technology	16
13	Input	17
13.1	Position of input terminals	17
13.2	Protection of the primary side	17
14	Output	18
14.1	Position of output terminals	18
14.2	Protection of the secondary side	18
14.3	Output characteristic curve	18
14.4	Meaning of NEC - Class 2 (National Electrical Code - Class 2)	19
15	Signaling	19
15.1	DC OK-LED	19
15.2	Floating signal contact	19

- 16 Derating20
 - 16.1 Temperature-dependent derating..... 20
 - 16.2 Installation height 20
 - 16.3 Position-dependent derating 20
- 17 Operating modes24
 - 17.1 Series operation 24
 - 17.2 Parallel operation 24
 - 17.3 Redundant operation..... 24
 - 17.4 Increasing power 25

3 Ordering data

Description	Type	Order No.	Pcs./Pkt.
Primary-switched TRIO POWER power supply with push-in connection for DIN rail mounting, input: 1-phase, output: 12 V DC/5 A C2LPS	TRIO-PS-2G/1AC/12DC/5/C2LPS	2903157	1
Accessories	Type	Order No.	Pcs./Pkt.
VARIOFACE module, with two equipotential busbars (P1, P2) for potential distribution, for mounting on NS 35 rails. Module width: 70.4 mm	VIP-2/SC/PDM-2/24	2315269	1
VARIOFACE module with push-in connection and two equipotential busbars (P1, P2) for potential distribution, for mounting on NS 35 rails. Module width: 57.1 mm	VIP-3/PT/PDM-2/24	2903798	1



The range of accessories is being continuously extended. The current range of accessories can be found in the download area for the product.

4 Technical data

Input data



Unless otherwise stated, all data applies for 25°C ambient temperature, 230 V AC input voltage, and nominal output current (I_N).

Input voltage range	100 V AC ... 240 V AC -15 % ... +10 % 110 V DC ... 250 V DC \pm 10 %
Extended input voltage range in operation	> 88 V DC
Switch-on voltage typ.	85 V DC
Shut-down voltage typ.	80 V DC
Electric strength, max.	\leq 300 V AC (15 s)
Network type	Star network
Frequency range (f_N)	50 Hz ... 60 Hz \pm 5 Hz
Current consumption (for nominal values) typ.	1.1 A (100 V AC) 1 A (120 V AC) 0.6 A (230 V AC) 0.6 A (240 V AC) 0.7 A (110 V DC) 0.3 A (250 V DC)
Discharge current to PE typ.	< 0.25 mA < 0.05 mA (264 V AC, 60 Hz)
Mains buffering	> 20 ms (120 V AC) > 110 ms (230 V AC)
Inrush surge current I^2t	< 0.6 A ² s
Switch-on current surge limitation typical after 1 ms	25 A



During the first few microseconds, the current flow into the filter capacitors is excluded.

Input fuse internal (device protection)	6.3 A
Choice of suitable circuit breakers	6 A ... 16 A (Characteristics B, C, D, K)



The external backup fuse must be approved for the (AC) supply voltage used and the voltage level.

Electric strength of the insulation

Insulation voltage input/output (IEC/EN 60950-1)	3 kV AC (type test) 1.5 kV AC (routine test)
Production test	2.5 kV DC

POWER factor	120 V AC	230 V AC
	> 0.6	> 0.5

Input connection data	
Connection method	Push-in connection
Conductor cross section, solid	0.2 mm ² ... 4 mm ²
Conductor cross section, flexible	0.2 mm ² ... 2.5 mm ²
Stranded conductor cross section with ferrule	0.2 mm ² ... 2.5 mm ²
Cross section AWG	24 ... 12
Stripping length	10 mm

Output data	
Nominal output voltage (U _N)	12 V DC ±1 %
Setting range of the output voltage (U _{Set}) (> 12 V DC, constant capacity restricted)	12 V DC ... 18 V DC
Nominal output current (I _N)	5 A
Short-circuit current	< 6 A DC (Permanent)
Control deviation change in load, static 10 % ... 90 %	< 1 %
Control deviation Dynamic load change 10 % ... 90 %, 10 Hz	< 3 %
Control deviation change in input voltage ±10 %	< 0.1 %
Short-circuit-proof	yes
No-load proof	yes
Residual ripple (with nominal values)	< 50 mV _{PP}
Peak switching voltages	< 20 mV _{PP}
Connection in parallel	Yes, for redundancy and increased capacity
Connection in series	yes
Feedback resistance	≤ 25 V
Circuit breaker against surge voltage at output by invasive foreign matter	≤ 25 V DC
Rise time typical	20 ms (U _{OUT} (10 % ... 90 %))

Output connection data	
Connection method	Push-in connection
Conductor cross section, solid	0.2 mm ² ... 4 mm ²
Conductor cross section, flexible	0.2 mm ² ... 2.5 mm ²
Stranded conductor cross section with ferrule	0.2 mm ² ... 2.5 mm ²
Conductor cross section AWG	24 ... 12
Stripping length	8 mm

LED signaling		
Signalization designation	DC OK	
Status indicator	LED	
Color	green	
Signal threshold	$U_{OUT} > 0.9 \times U_N$ ($U_N = 12 \text{ V DC}$)	
Relay output		
Signalization designation	DC OK	
Contact assignment	13/14 (closed)	
Maximum contact load	30 V AC / 30 V DC (100 mA)	
Signal threshold	$U_{OUT} > 0.9 \times U_N$ ($U_N = 12 \text{ V DC}$)	
Signal connection data		
Connection method	Push-in connection	
Conductor cross section, solid	0.2 mm ² ... 1.5 mm ²	
Conductor cross section, flexible	0.2 mm ² ... 1.5 mm ²	
Stranded conductor cross section with ferrule	0.2 mm ² ... 1.5 mm ²	
Conductor cross section AWG	24 ... 16	
Stripping length	8 mm	
Reliability	230 V AC	
MTBF (IEC 61709, SN 29500)	> 5800000 h (25 °C) > 2900000 h (40 °C) > 1500000 h (60 °C)	
General data		
Degree of protection	IP20	
Protection class	II (in closed control cabinet)	
Inflammability class in acc. with UL 94 (housing / terminal blocks)	V0	
Type of housing	Polycarbonate	
Hood version	Polycarbonate	
Dimensions W / H / D (state of delivery)	30 mm / 130 mm / 115 mm	
Weight	0.32 kg	
Power dissipation	120 V AC	230 V AC
Maximum power dissipation in no-load condition	typ. 0.4 W	typ. 0.8 W
Power loss nominal load max.	typ. 10.7 W	typ. 9.9 W
Efficiency	120 V AC	230 V AC
	typ. 85 %	typ. 85.6 %

Ambient conditions

Ambient temperature (operation) -25 °C ... 70 °C (> 60 °C Derating: 2.5 %/K)



The ambient temperature (operation) refers to UL 508 surrounding air temperature.

Ambient temperature (storage/transport) -40 °C ... 85 °C

Max. permissible relative humidity (operation) ≤ 95 % (at 25 °C, non-condensing)

Installation height ≤ 5000 m (> 2000 m, Derating: 10 %/1000 m)

Vibration (operation) DNV GL CG-0339 / Class B
2 Hz - 100 Hz resonance search, 90 min. in resonance,
2 Hz - 25 Hz, ±1.6 mm amplitude,
25 Hz - 100 Hz, 4g acceleration

Shock 18 ms, 30g, in each space direction (according to IEC 60068-2-27)

Degree of pollution 2

Climatic class 3K3 (in acc. with EN 60721)

Overvoltage category

EN 60950-1

II

EN 62477-1

III

Standards

Safety of power supply units up to 1100 V (insulation distances) DIN EN 61558-2-16

Electrical safety (of information technology equipment) IEC 60950-1/VDE 0805 (SELV)

SELV IEC 60950-1 (SELV) and EN 60204-1 (PELV)

Safe isolation DIN VDE 0100-410

Limitation of mains harmonic currents EN 61000-3-2

Rail applications EN 50121-4

Approvals

UL UL Listed UL 508
UL/C-UL Recognized UL 60950-1
NEC Class 2 as per UL 1310



Current approvals/permissions for the product can be found in the download area under phoenixcontact.net/products.

Electromagnetic compatibility		
Conformance with EMC Directive 2014/30/EU		
Noise emission according to EN 61000-6-3 (residential and commercial) and EN 61000-6-4 (industrial)		
CE basic standard	Minimum normative requirements	Higher requirements in practice (covered)
Conducted noise emission EN 55016	EN 61000-6-4 (Class A)	EN 61000-6-3 (Class B)
Noise emission EN 55016	EN 61000-6-4 (Class A)	EN 61000-6-3 (Class B)
Harmonic currents EN 61000-3-2	Class B	Class A, B
Flicker EN 61000-3-3	not required	0 kHz ... 2 kHz
Immunity according to EN 61000-6-1 (residential), EN 61000-6-2 (industrial)		
CE basic standard	Minimum normative requirements of EN 61000-6-2 (CE) (immunity for industrial environments)	Higher requirements in practice (covered)
Electrostatic discharge EN 61000-4-2		
Housing contact discharge	4 kV (Test Level 2)	6 kV (Test Level 3)
Housing air discharge	8 kV (Test Level 3)	8 kV (Test Level 3)
Comments	Criterion B	Criterion A
Electromagnetic HF field EN 61000-4-3		
Frequency range	80 MHz ... 1 GHz	80 MHz ... 1 GHz
Test field strength	10 V/m (Test Level 3)	10 V/m (Test Level 3)
Frequency range	1.4 GHz ... 2 GHz	1 GHz ... 2 GHz
Test field strength	3 V/m (Test Level 2)	10 V/m (Test Level 3)
Frequency range	2 GHz ... 2.7 GHz	2 GHz ... 3 GHz
Test field strength	1 V/m (Test Level 1)	10 V/m (Test Level 3)
Comments	Criterion B	Criterion A
Fast transients (burst) EN 61000-4-4		
Input	2 kV (Test Level 3 - asymmetrical)	4 kV (Test Level 3 - asymmetrical)
Output	2 kV (Test Level 3 - asymmetrical)	2 kV (Test Level 3 - asymmetrical)
Signal	1 kV (Test Level 3 - asymmetrical)	2 kV (Test Level 3 - asymmetrical)
Comments	Criterion B	Criterion A

Immunity according to EN 61000-6-1 (residential), EN 61000-6-2 (industrial)			
CE basic standard		Minimum normative requirements of EN 61000-6-2 (CE) (immunity for industrial environments)	Higher requirements in practice (covered)
Surge current loads (surge) EN 61000-4-5			
	Input	1 kV (Test Level 3 - symmetrical) 2 kV (Test Level 3 - asymmetrical)	3 kV (Test Level 4 - symmetrical) 6 kV (Test Level 4 - asymmetrical)
	Output	0.5 kV (Test Level 2 - symmetrical) 0.5 kV (Test Level 1 - asymmetrical)	1 kV (Test Level 3 - symmetrical) 2 kV (Test Level 3 - asymmetrical)
	Signal	0.5 kV (Test Level 1 - asymmetrical)	1 kV (Test Level 2 - asymmetrical)
	Comments	Criterion B	Criterion A
Conducted interference EN 61000-4-6			
	Input/Output/Signal	asymmetrical	asymmetrical
	Frequency range	0.15 MHz ... 80 MHz	0.15 MHz ... 80 MHz
	Voltage	10 V (Test Level 3)	10 V (Test Level 3)
	Comments	Criterion A	Criterion A
Voltage dips EN 61000-4-11			
Input voltage (230 V AC , 50 Hz)			
	Voltage dip on	70 % , 25 periods (Test Level 2)	70 % , 25 periods (Test Level 2)
	Comments	Criterion C	Criterion A
	Voltage dip on	40 % , 10 periods (Test Level 2)	40 % , 10 periods (Test Level 2)
	Comments	Criterion C	Criterion A
	Voltage dip on	0 % , 1 period (Test Level 2)	0 % , 1 period (Test Level 2)
	Comments	Criterion B	Criterion A
Key			
Criterion A	Normal operating behavior within the specified limits.		
Criterion B	Temporary impairment to operational behavior that is corrected by the device itself.		
Criterion C	Temporary adverse effects on the operating behavior, which the device corrects automatically or which can be restored by actuating the operating elements.		
Emitted interference in acc. with EN 61000-6-3			
Radio interference voltage in acc. with EN 55011	EN 55011 (EN 55022) Class B, area of application: Industry and residential		
Emitted radio interference in acc. with EN 55011	EN 55011 (EN 55022) Class B, area of application: Industry and residential		

5 Safety regulations and installation notes



Before startup please ensure:

- Installation and startup may only be carried out by qualified personnel.
- The relevant country-specific regulations must be observed.



NOTE: Danger if used improperly

- The device is a built-in device.
- The IP20 degree of protection (IEC 60529/EN 60529) of the device is intended for use in a clean and dry environment. Do not subject the device to any load that exceeds the described limits.
- Do not subject the device to mechanical and/or thermal loads that exceed the specified limits.
- It is not permissible to open or modify the device. Do not repair the device yourself but replace it with an equivalent device. Repairs may only be carried out by the manufacturer. The manufacturer is not liable for damage resulting from violation.



CAUTION:

Before startup please ensure:

- Connection must be performed by specialist personnel and protection against electric shock ensured.
- It must be possible to switch off the device outside the power supply according to the regulations in EN 60950-1 (e.g., by line protection on the primary side).
- All feed lines are sufficiently protected and dimensioned!
- All output lines are dimensioned according to the maximum output current of the device or separately protected!
- Sufficient convection is guaranteed!



EXPLOSION HAZARD!

Only remove equipment when it is disconnected and not in the potentially explosive area.

DANGER

Never carry out work on live parts!
The housing can become very hot, depending on the ambient temperature and load!

6 High-voltage test (HIPOT)

This protection class II power supply is subject to the Low Voltage Directive and is factory tested. During the HIPOT test (high-voltage test), the insulation between the input circuit and output circuit is tested for the prescribed electric strength values, for example. The test voltage in the high-voltage range is applied at the input and output terminal blocks of the power supply. The operating voltage used in normal operation is a lot lower than the test voltage used.



The test voltage should rise and fall in ramp form. The relevant rise and fall time of the ramp should be at least seconds.

6.1 High-voltage dielectric test (dielectric strength test) and why must it be performed?

In order to protect the user, power supplies (as electric components with a direct connection to potentially hazardous voltages) are subject to more stringent safety requirements. For this reason, permanent safe electrical isolation between the hazardous input voltage and the touch-proof output voltage as safety extra-low voltage (SELV) must always be ensured.

In order to ensure permanent safe isolation of the AC input circuit and DC output circuit, high-voltage testing is performed as part of the safety approval process (type test) and manufacturing (routine test).

6.2 High-voltage dielectric test during the manufacturing process

During the manufacturing process for the power supply, a high-voltage test is performed as part of the dielectric test in accordance with the specifications of IEC/UL/EN 60950-1. The high-voltage test is performed with a test voltage of at least 1.5 kV AC / 2.2 kV DC or higher. Routine manufacturing tests are inspected regularly by a certification body.

6.3 High-voltage dielectric test performed by the customer

Apart from routine and type tests to guarantee electrical safety, the end user does not have to perform another high-voltage test on the power supply as an individual component. According to EN 60204-1 (Safety of machinery - Electrical equipment of machines) the power supply can be disconnected during the high-voltage test and only installed once the high-voltage test has been completed.

6.4 Performing high-voltage testing

If high-voltage testing of the control cabinet or the power supply as a stand-alone component is planned during final inspection and testing, the following features must be observed.

- The power supply wiring must be implemented as shown in the wiring diagram.
- The maximum permissible test voltages must not be exceeded.

Avoid unnecessary loading or damage to the power supply due to excessive test voltages.



For the relevant applicable test voltages and insulation distances, refer to the corresponding table (see technical data: electric strength of the insulation section).

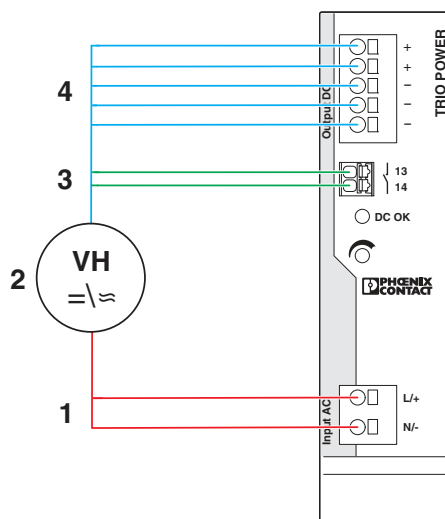

Figure 1 Potential-related wiring for the high-voltage test

Key

No.	Designation	Color coding	Potential levels
1	AC input circuit	Red	Potential 1
2	High-voltage tester	--	--
3	Signal contacts	Green (optional)	Potential 2
4	DC output circuit	Blue	Potential 2

7 Basic circuit diagram

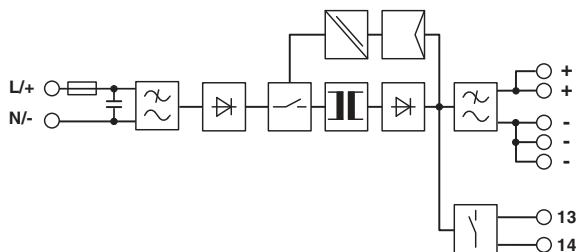

Figure 2 Block diagram

Key:	
	Rectification
	Switch
	Electrically isolated signal transmission
	Regulation
	Transformer
	Filter
	Floating switching output

8 Structure

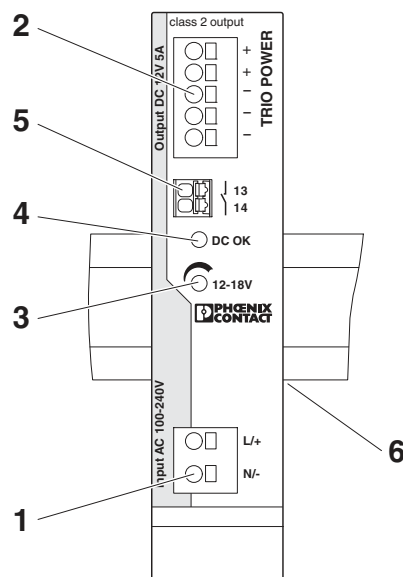

Figure 3 Function elements

No.	Description of the function elements
1.	Connection terminal block input voltage: Input L/N
2.	Connection terminal block output voltage: Output DC +/-
3.	Potentiometer, output voltage: 12 V DC ... 18 V DC
4.	Signaling DC OK LED
5.	Floating signal contact: max. 30 V AC/DC, 100 mA
6.	Integrated universal snap-on foot

9 Cooling

Heat is dissipated from the power supply via the heatsinks integrated into the housing surfaces. Convection to dissipate heat from the power supply only takes place in small dimensions above the housing openings.

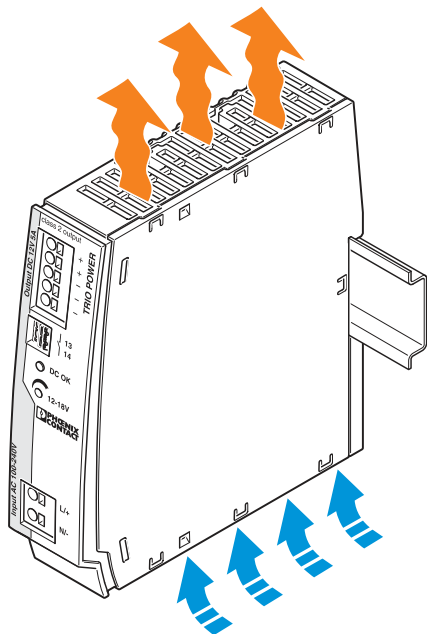

Figure 4 Convection



The power supply can be aligned without minimum lateral spacing.



The device can be snapped onto all DIN rails in accordance with EN 60715 and should be mounted in the normal mounting position.



To ensure sufficient wiring space to wire the power supply, we recommend a vertical minimum clearance from other devices of 50 mm. Depending on the cable duct used, a smaller clearance may be possible.

10 Mounting position and dimensions

10.1 Mounting position

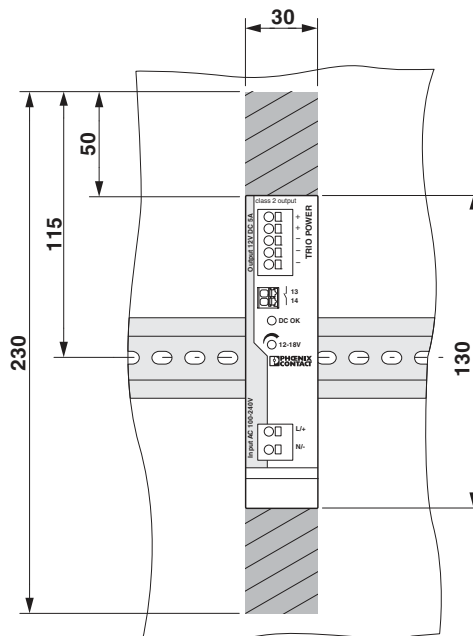

Figure 5 Locked areas

Possible mounting positions:

Normal mounting position, installation depth 115 mm (+ DIN rail)

10.2 Device dimensions

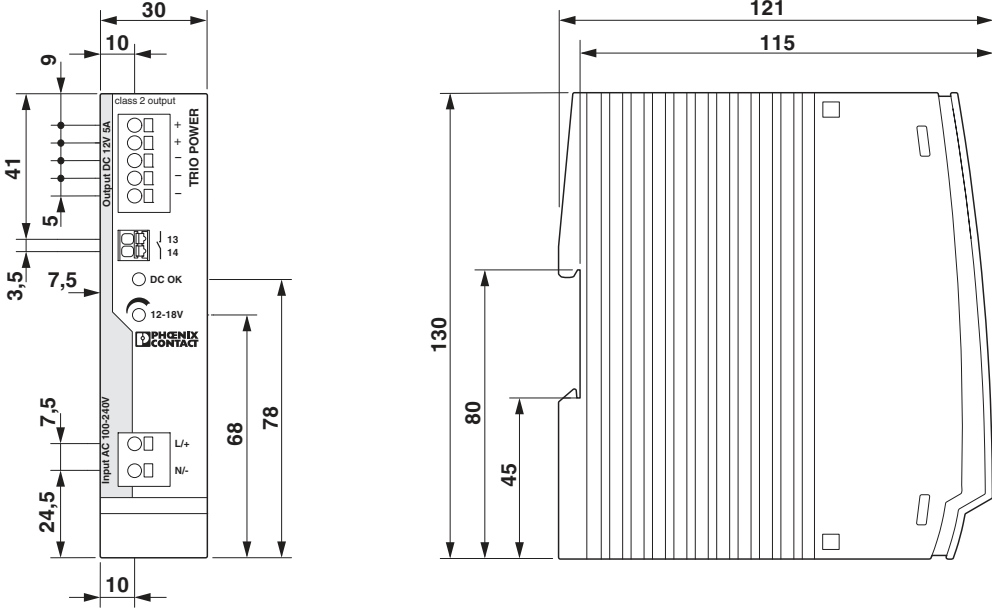

Figure 6 Device dimensions

11 Mounting/removal

11.1 Assembly

Position the module with the DIN rail guide on the upper edge of the DIN rail, and snap it in with a downward motion.

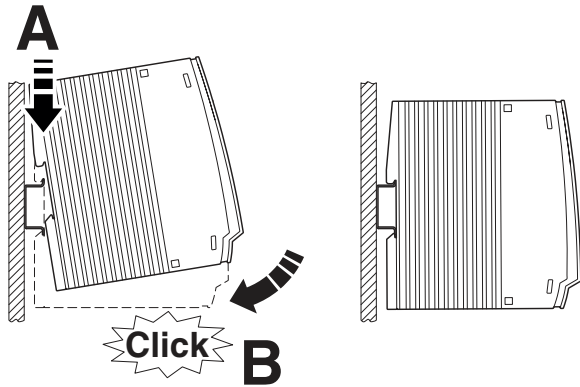

Figure 7 Assembly on standard DIN rail

11.2 Removal

Pull the snap lever open with the aid of a screwdriver and slide the module out at the lower edge of the DIN rail.

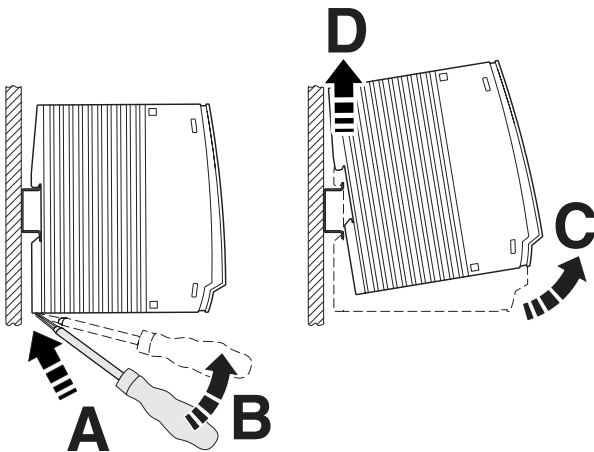

Figure 8 Removing the DIN rail

12 Device connection terminal blocks

12.1 Push-in connection technology

All connection terminal blocks on the power supply have push-in connection technology on the front. The power supply is wired by simply plugging in the connecting cables, no tools are required. For the necessary connection parameters for the terminal blocks, please refer to the technical data.

12.1.1 Plug in connecting cable

The wiring is carried out by simply plugging the connecting cable into the contact opening provided. Insert the connecting cable as far as it will go.

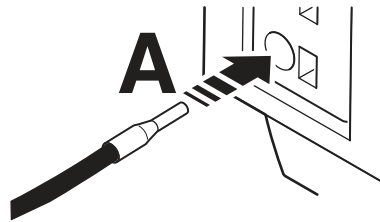

Figure 9 Insert connecting cable (push-in connection technology)

12.1.2 Loosen the connecting cable

To disconnect the wiring, take a suitable screwdriver and insert it into the opening for release. Then carefully pull the connecting cable out of the contact opening.

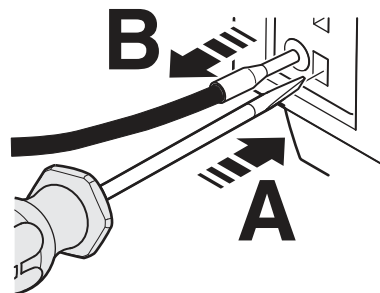

Figure 10 Release connecting cable (push-in connection technology)

13 Input

The power supply can be operated on single-phase AC or DC power grids in accordance with the nominal input voltage. Connection is via the INPUT L+/N- connection terminal blocks.

For operation on two of the phase conductors of a three-phase system, an isolating facility for all poles must be provided.

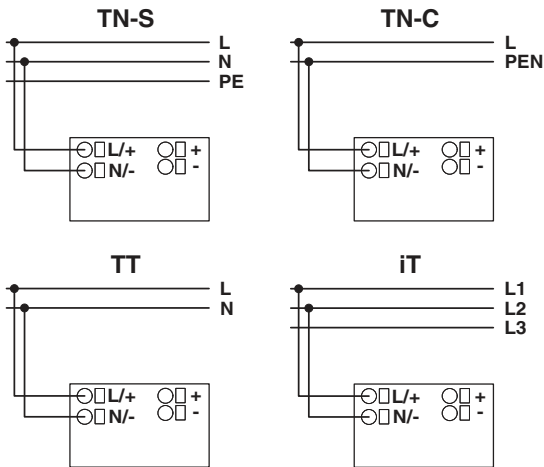

Figure 11 Network types

13.1 Position of input terminals

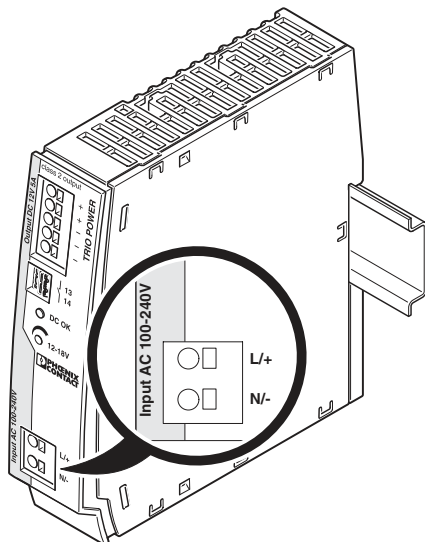

Figure 12 Position of input terminals

13.2 Protection of the primary side

Installation of the device must correspond to EN 60950 regulations. It must be possible to disconnect the device from the voltage using a suitable separator outside the power supply. For example, the primary-side line protection is suitable for this (see technical data).

An internal, approved AC/DC fuse is available as device protection. Additional device protection is not required.



If an internal fuse trips, this is due to a device fault. In this case, the device must be inspected in the factory. Opening the device or repairing it yourself is prohibited.

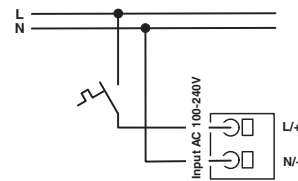

Figure 13 Schematic diagram, switching the input terminals

14 Output

A DC voltage for supplying the load is provided at the output of the power supply. The load is connected via the OUTPUT +/- connection terminal blocks.

By default, the power supply is pre-set to a nominal output voltage of 12 V DC.

The output voltage can also be set to the range from 12 V DC to 18 V DC using the potentiometer in order to compensate for a possible voltage drop due to the long cable lengths between the power supply and the load to be supplied.

14.1 Position of output terminals

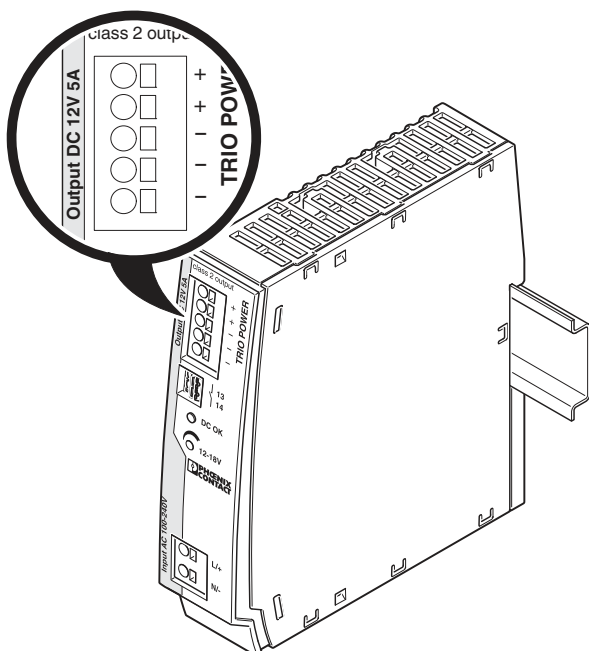

Figure 14 Position of output terminals

14.2 Protection of the secondary side

The power supply is electronically short-circuit-proof and idling-proof. In the event of an error, the output voltage is limited. It must be ensured that all output cables are dimensioned accordingly for the maximum output current or have separate protection.

The connecting cables on the secondary side should have large cross sections to keep the voltage drops in the cables as low as possible.

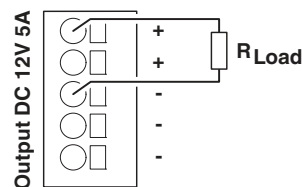

Figure 15 Schematic diagram, switching the output terminals

14.3 Output characteristic curve

The power supply operates according to the U/I characteristic curve shown in the figure. In the event of a short circuit and overload on the secondary side, the output current is limited. The module does not switch off, but instead continues to supply the output current. The secondary voltage is then reduced until the short circuit is eliminated. The U/I characteristic curve enables high switch-on currents of capacitive loads or inductive loads to be reliably supplied with energy.

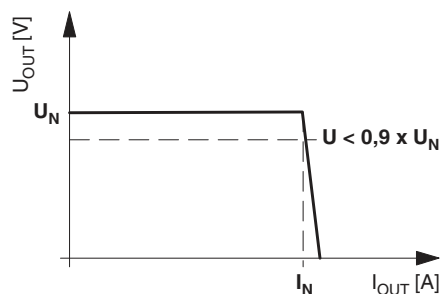

Figure 16 U/I characteristic curve

- $U_N = 12 \text{ V DC}$
- $I_N = 5 \text{ A}$
- $P_N = 60 \text{ W}$

14.4 Meaning of NEC - Class 2 (National Electrical Code - Class 2)

The approval of the power supply as a “Class 2 Output” in accordance with American standard ANSI/UL 1310 ensures that the power supply only provides limited power even in the event of an error. This increases safety to such an extent that the simulated circuits are also deemed very safe in terms of fire protection. This can result in reduced installation work.

The output of the power supply is configured in accordance with ANSI/UL 1310 (Class 2 power supplies) and approved as such with limited power. This ensures that the limit values described in UL 1310 are not exceeded.

The power supply is able to supply up to $1.5 \times I_N$ for 1 s at maximum load. If less dynamic power is required, this can also be supplied for more than 1 s.

15 Signaling

15.1 DC OK-LED

The DC OK-LED is available for function monitoring. The LED is continuously illuminated when the output voltage is $> 90\%$ of the nominal output voltage U_{OUT} (12 V DC).

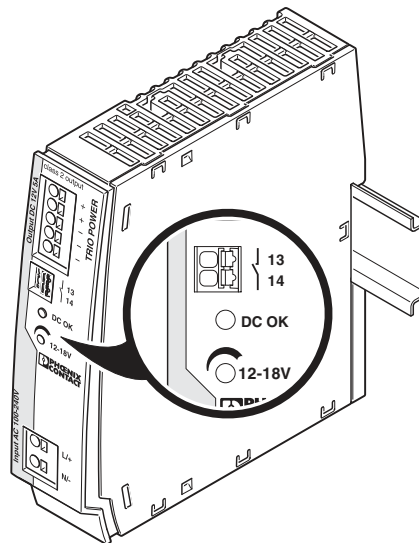

Figure 17 Location of the elements

15.2 Floating signal contact

A floating diagnostics contact can be used to forward data to a higher-level control system. When opened, the diagnostics contact indicates an underrange of more than 90% for the nominal output voltage U_{OUT} .

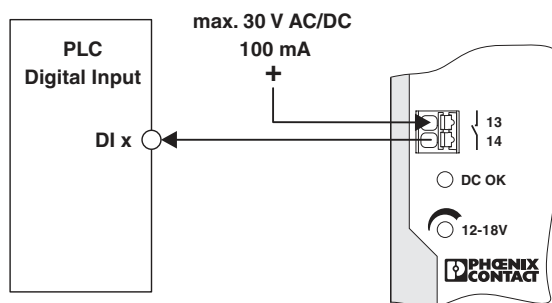

Figure 18 Wiring principle

16 Derating

16.1 Temperature-dependent derating

With an ambient temperature of up to +60°C, the device supplies the continuous output current of I_N . In the case of ambient temperatures above +60°C, the output current must be reduced by 2.5 % per Kelvin increase in temperature. The device does not switch off at ambient temperatures of +70°C or thermal overload. The output capacity is reduced as far as necessary to provide device protection. After it has cooled down, the output capacity is increased again.

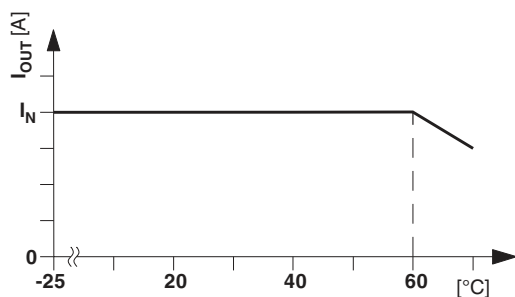

Figure 19 Temperature derating in normal mounting position

16.2 Installation height

The power supply can be operated at an installation height of up to 2000 m without any limitations. Different data applies for installation locations above 2000 m due to the differing air pressure and the reduced convection cooling associated with this (see technical data section).

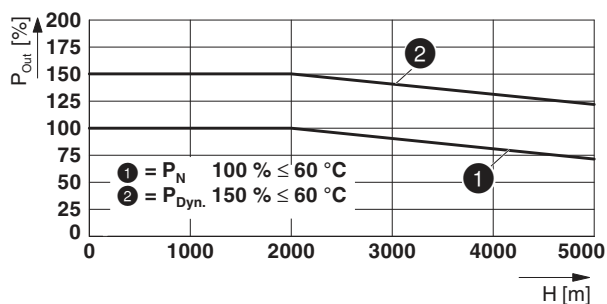

Figure 20 Output power depending on the installation height

16.3 Position-dependent derating

The power supply can be installed onto all 35 mm DIN rails according to EN 60715. The normal mounting position of the power supply is horizontal.

When installing in a different mounting position, derating should be adhered to.

The characteristic curve can be used to determine the maximal output power to be drawn for each ambient temperature for different mounting positions.

Normal mounting position

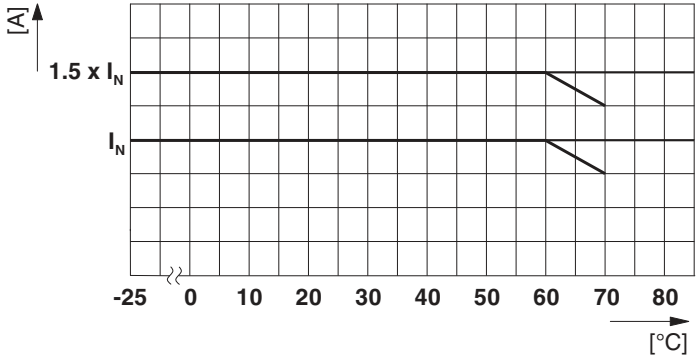
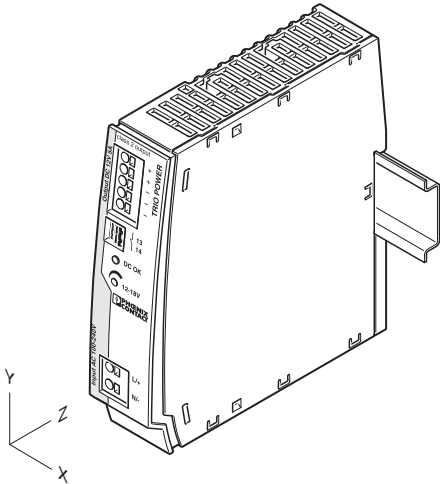

Rotated mounting position 90° X-axis

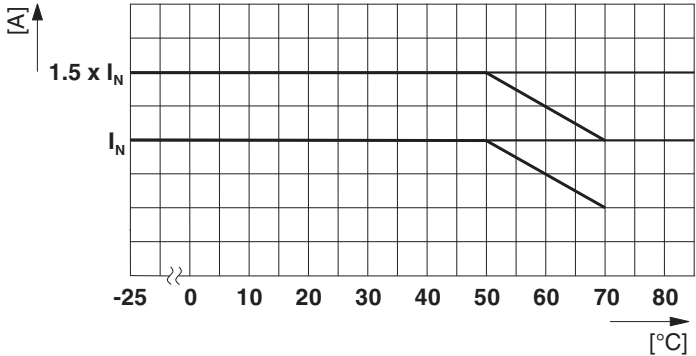
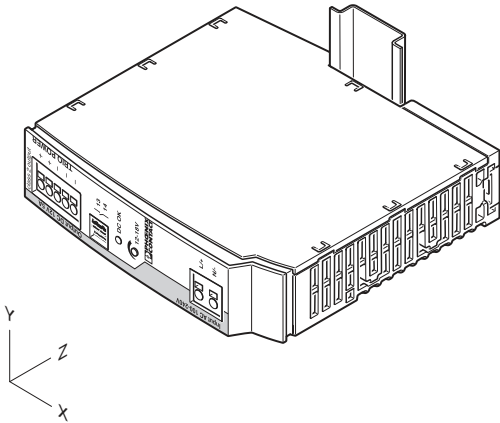

Rotated mounting position 180° X-axis

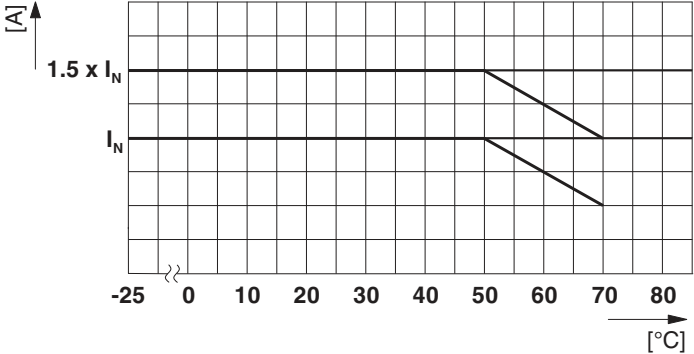
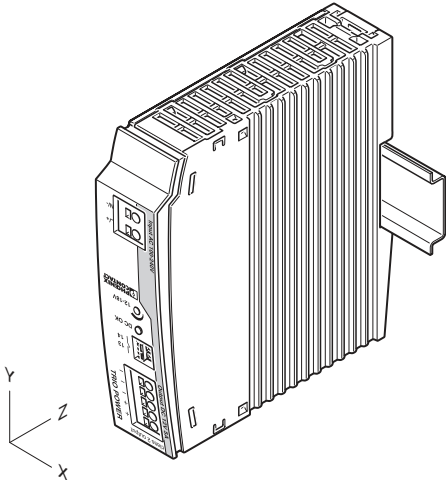

Rotated mounting position 270° X-axis

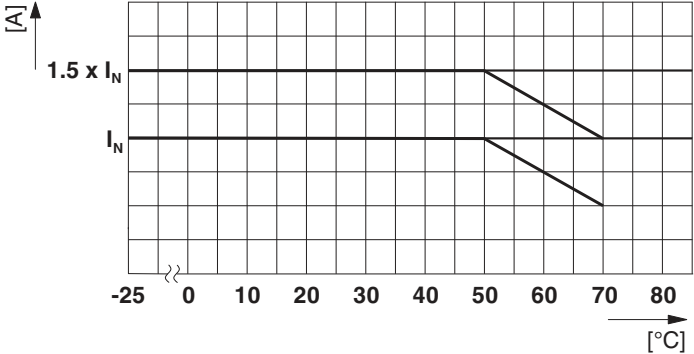
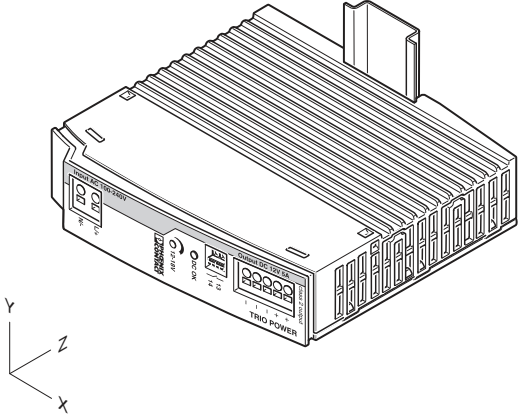

Rotated mounting position 90° Z-axis

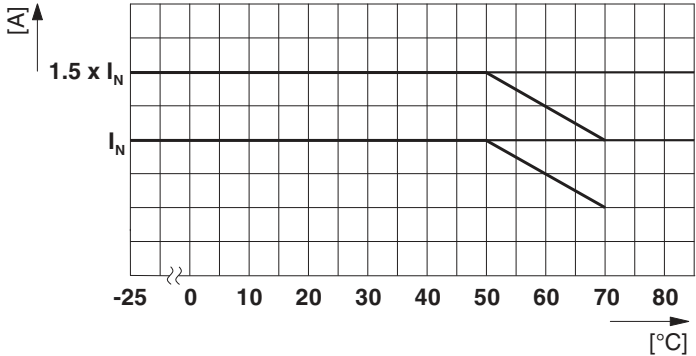
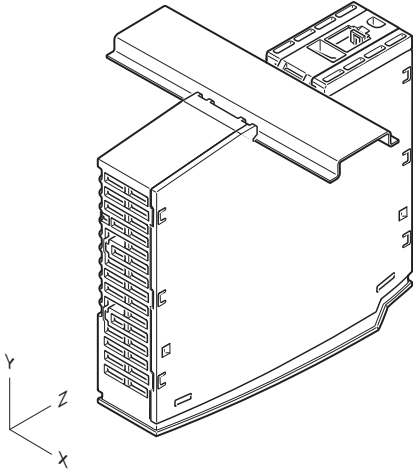

Rotated mounting position 270° Z-axis

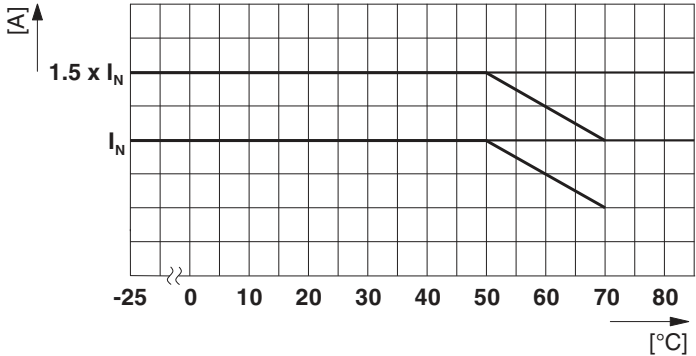
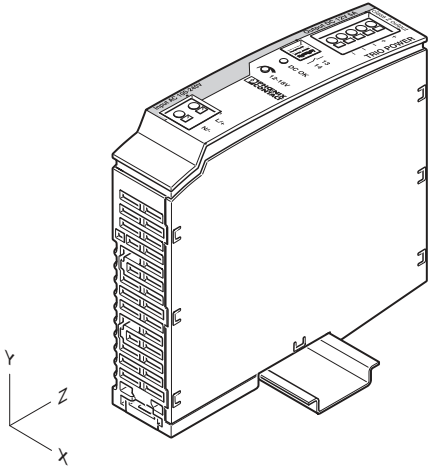

17 Operating modes

17.1 Series operation

Two power supplies can be switched in series, to double the output voltage. For connection in series, only power supplies of the same performance class should be used. An output voltage of, for example, 24 V DC can be provided, if two 12 V power supplies are connected in series.

Various voltage levels are made possible by varying the switching of the respective output voltage and the measurement reference point.

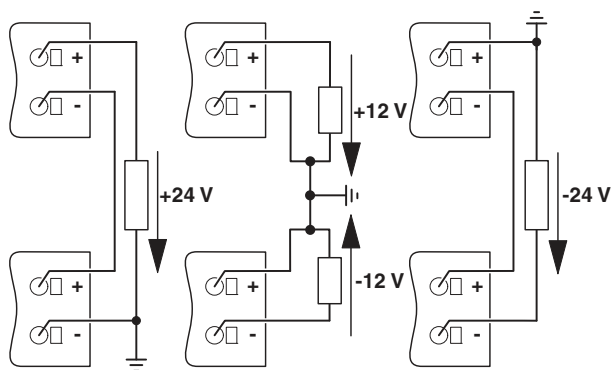

Figure 21 Wiring principle, voltage levels with two power supplies

17.2 Parallel operation

Devices of the same type can be connected in parallel to increase both redundancy and power. By default upon delivery, no further adjustments are required.

If the output voltage is adjusted, a uniform distribution of power is guaranteed by setting all parallel operated power supply units to exactly the same output voltage.

To ensure symmetrical current distribution we recommend that all cable connections from the power supply unit to the busbar are the same length and have the same cross section.

Depending on the system, for parallel connection of more than two power supplies a protective circuit should be installed at each individual device output (e.g., decoupling diode, DC fuse or circuit breaker). This prevents high return currents in the event of a secondary device fault.

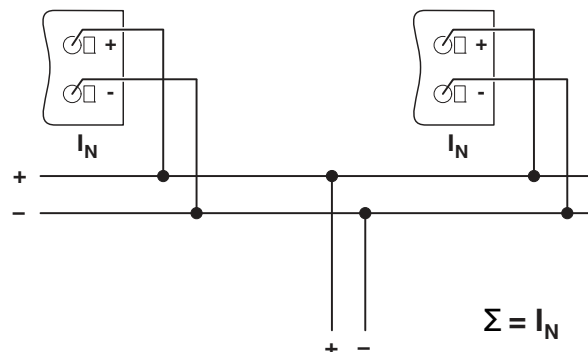

Figure 22 Schematic diagram in parallel operation

17.3 Redundant operation

Redundant circuits are suitable for supplying systems which place particularly high demands on operational reliability. If a fault occurs in the primary circuit of the first power supply, the second device automatically takes over the complete power supply without interruption, and vice versa. To this end, the power supplies to be connected in parallel are dimensioned so that the total current requirements of all loads can be fully met by a single power supply. External decoupling diodes are required for 100% redundancy.

17.3.1 Decoupling with diode module

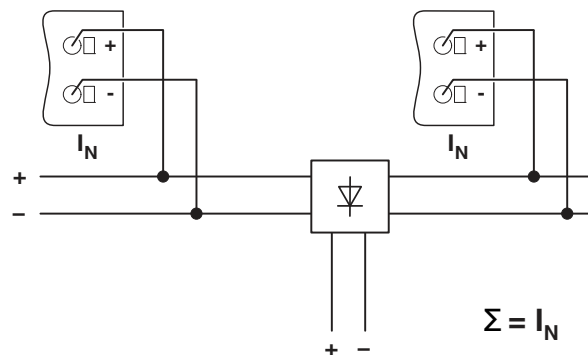

Figure 23 Schematic diagram, decoupling with diode module

17.4 Increasing power

The output current can be increased to $n \times I_N$ in the case of n parallel connected devices. Parallel connection for increasing power is used when extending existing systems. A parallel connection is recommended if the power supply unit does not cover the current consumption of the most powerful load. Otherwise, the load should be distributed between individual devices that are independent from one another.

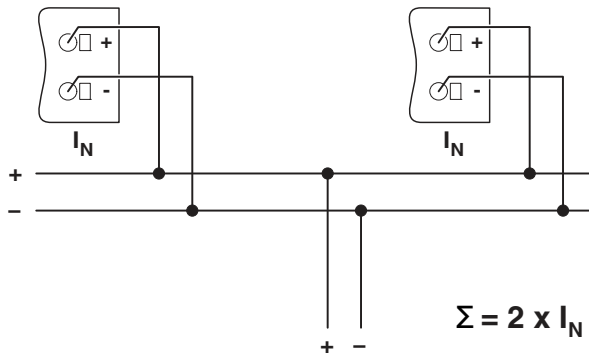

Figure 24 Schematic diagram of increased performance