

HPL - SERIES

BUL86201

REV. B

ASSEMBLY INSTRUCTIONS FOR HPLW / HPLD

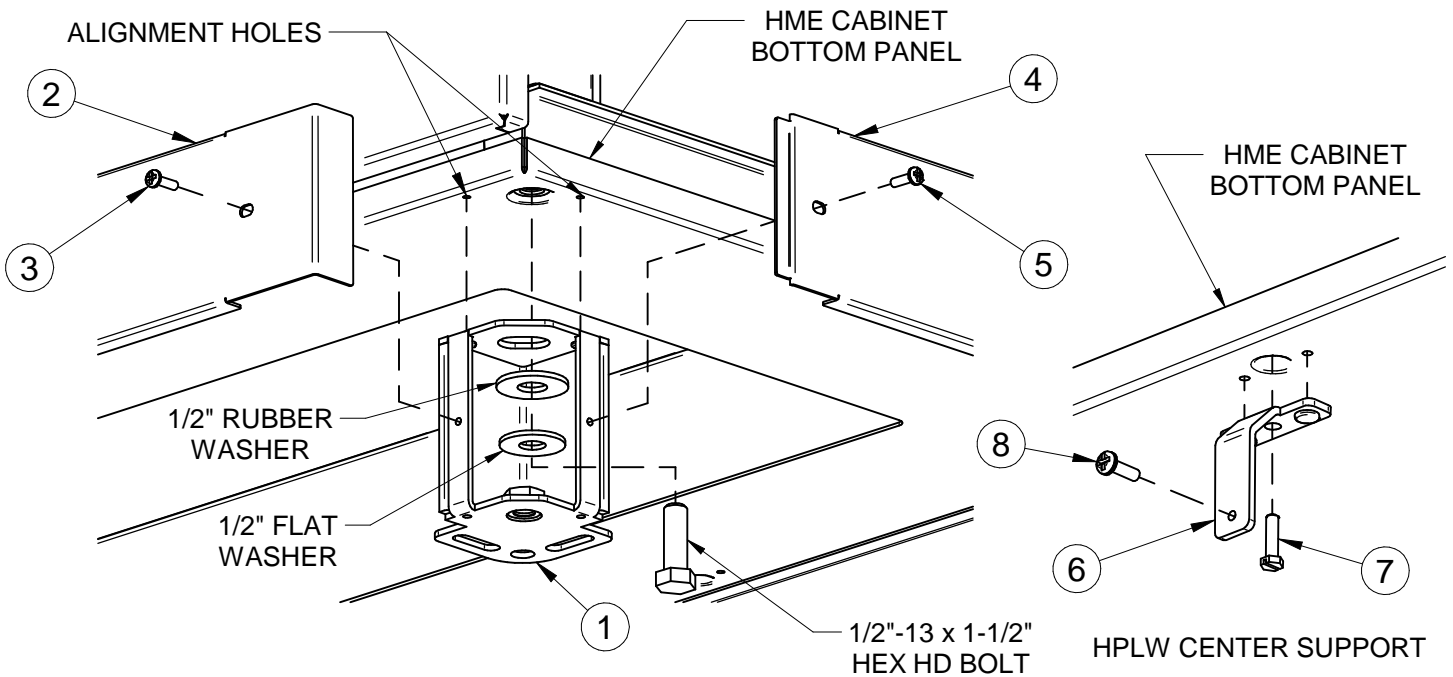

- A) Elevate cabinet to clear the height of the plinth plus a workable extra distance. (approx. 1" higher than plinth height).
- B) Remove first 1/2-13 x 1-1/2" bolt & 1/2" washer holding bottom panel using 3/4" socket wrench.
- C) Orient plinth corner post (item 1) as shown and insert the two pins into the alignment holes in the bottom panel.
- D) Use 1/2" bolt and washers from Step A to secure plinth corner post to the frame through the bottom panel hole.
Note: Tighten 1/2" bolt to 80 ft lb torque, over tightening of this bolt can cause alignment issues.
- E) Repeat Steps A to D for each corner.
- F) If a HPLD is to be used install the plinth depth cover panels (item 4) with the #10-32 x 5/8" black screw provided (item 5).
- G) Install plinth width cover panels (item 2) with #10-32 x 5/8" black screws provided (item 3). HPLW's exceeding 800mm wide use center support hardware provided (items 6, 7, 8).

HPLW PARTS LIST		
ITEM No.	DESCRIPTION	QTY
1	PLINTH CORNER POST	4
2	WIDTH COVER PANEL	2
3	#10-32 x 5/8 BLACK SCREW	4

HPLD PARTS LIST		
ITEM No.	DESCRIPTION	QTY
4	DEPTH COVER PANEL	2
5	#10-32 x 5/8 BLACK SCREW	4

CENTER SUPPORT (SIZES OVER 800mm WIDE)		
ITEM No.	DESCRIPTION	QTY
6	CENTER SUPPORT BRACKET	2
7	#12 x 3/4 HEX HEAD SCREW	2
8	#10-32 x 5/8 BLACK SCREW	2

	5/16" & 3/4" Socket Wrench	#2 Phillips Screw Driver

