

LOC		DIST		REVISIONS			
P	LTR	DESCRIPTION	DATE	OWN	APVD		
N	REV PER	ECO-10-001170	27JAN10	PY	RL		

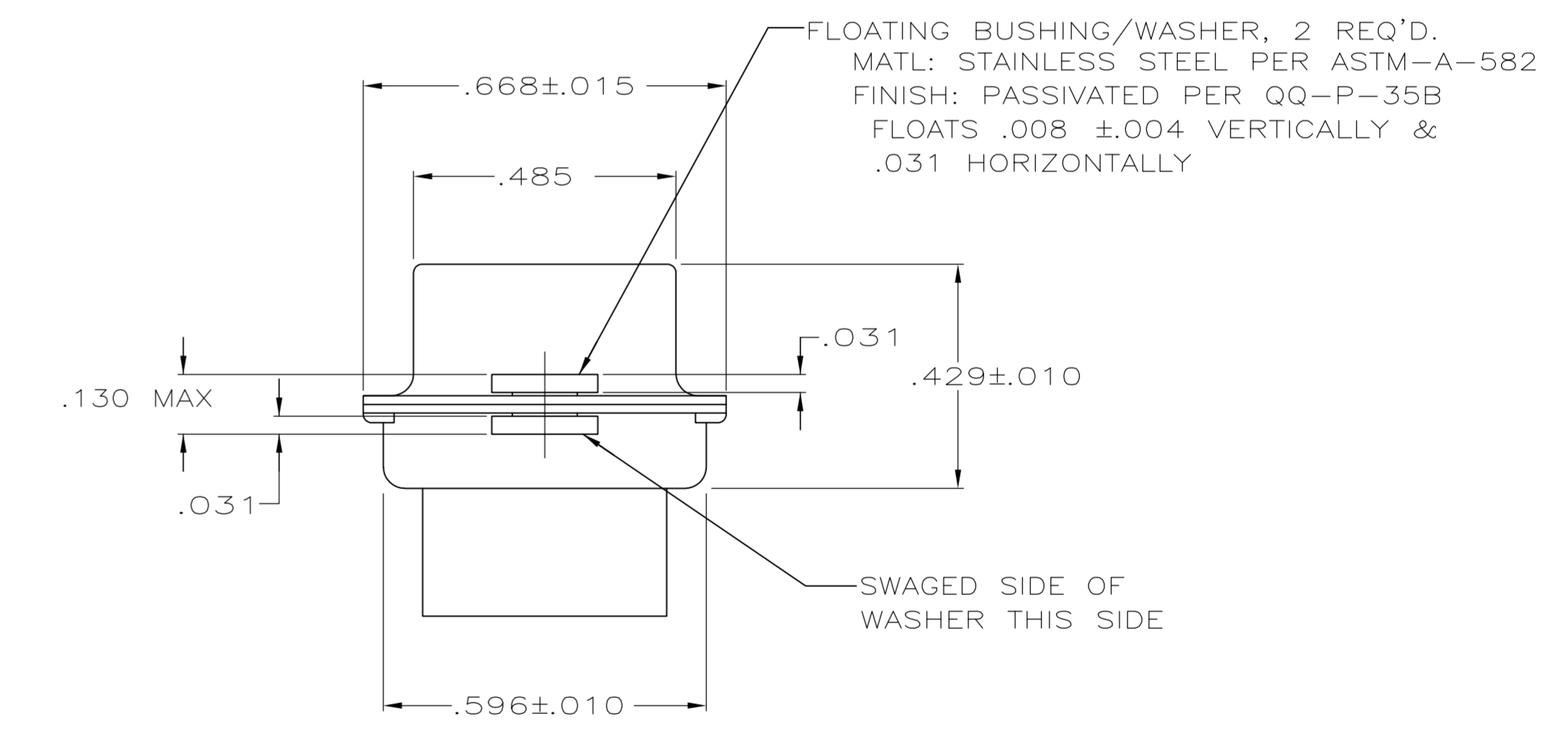
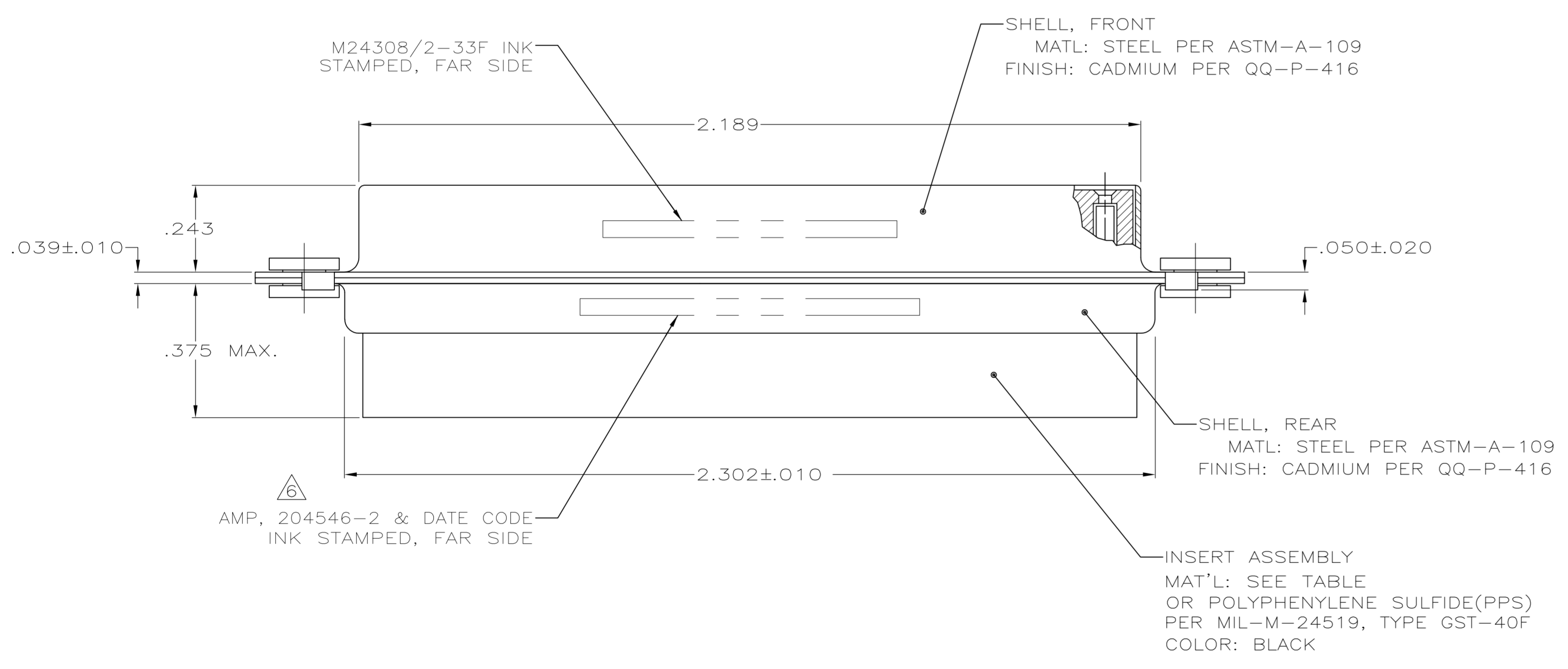
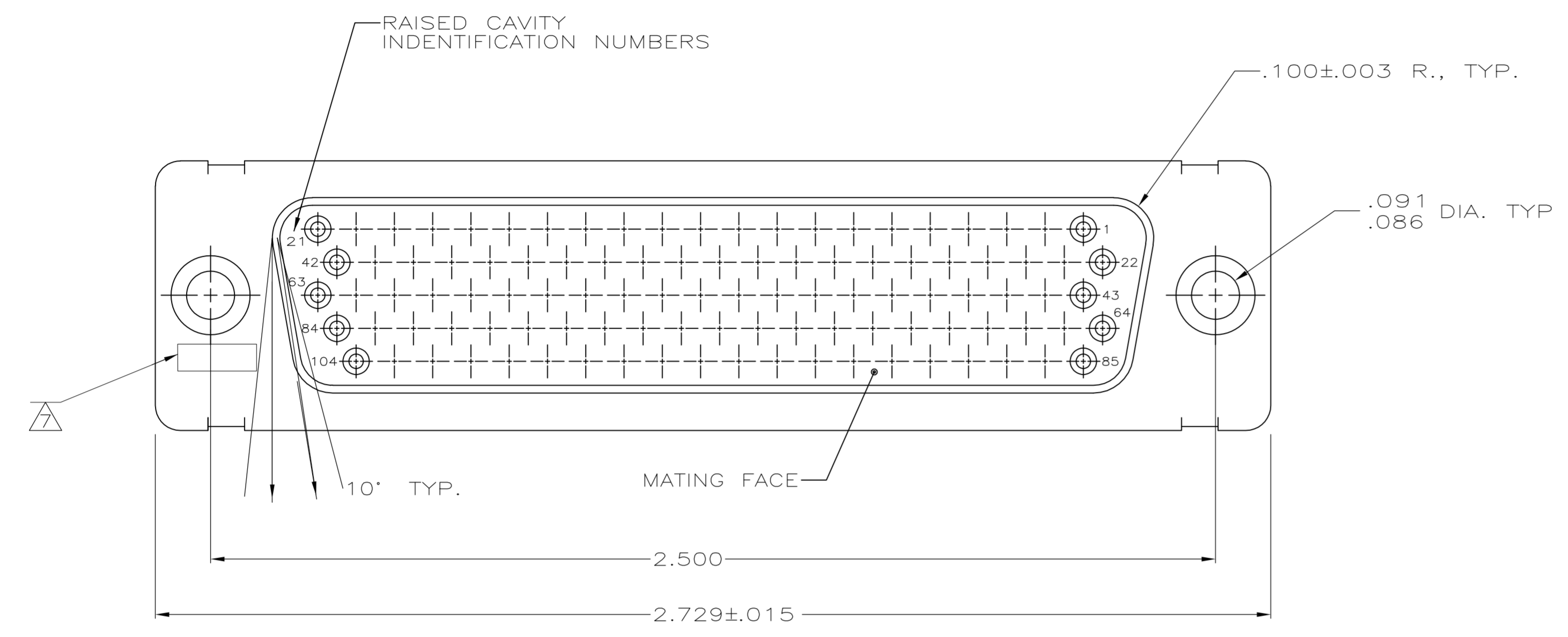

1. THIS RCPT. IS DESIGNED TO CONFORM TO THE LATEST ISSUE OF MIL-C-24308
 2. MAX WIRE INSUL TO BE USED WITH THIS RCPT IS .054 DIA
 3. METAL RETENTION CLIPS ARE INCLUDED IN INSERTS
 4. PACKAGE STAMPED M 24308/2-302F
 5. THIS RCPT. WILL ACCEPT SIZE 22 SOCKET CONTACT M 24308/12 OR AMP # 204351
- AMP PART NO. STAMPED ON CONNECTOR REPRESENTS KIT NUMBER WITH CONTACTS

OBSOLETE	PHENOLIC COLOR: BLACK	204534-2
	DIALYL PATHALATE COLOR: BLUE	204534-1
	INSERT MAT'L	PART NO

THIS DRAWING IS A CONTROLLED DOCUMENT.		DWN C.C.THOMAS CHK F.C.BALLEW	27JAN2010 1-25-88	Tyco Electronics Corporation Harrisburg, PA 17105-3608	
DIMENSIONS: INCHES	TOLERANCES UNLESS OTHERWISE SPECIFIED:	APVD F.C.BALLEW	1-25-88	NAME AMPLITE RCPT FOR SOCKET CONTACTS HI-DENSITY D CONNECTOR, SIZE 6 (104 POSN) SERIES 90 WITH FLOATING BUSHINGS	
0 PLC ± -	1 PLC ± -	PRODUCT SPEC		SIZE A1	CAGE CODE 00779
2 PLC ± -	3 PLC ± .005	APPLICATION SPEC		DRAWING NO 204534	RESTRICTED TO
4 PLC ± -	ANGLES ± 0'30"	WEIGHT		CUSTOMER DRAWING	SCALE 4:1 SHEET 1 OF 1 REV N