

FTDI Chip

VM800P Datasheet

Embedded Video Engine Plus Module



General Purpose Multi Media Controller

The VM800P is a development module for FTDI's FT800, which is used to develop and demonstrate the functionality of the FT800 Embedded Video Engine, EVE.

The VM800P is a stand-alone display system which has a flash based microcontroller on board, thus providing a fully integrated display system ready to go.

The VM800P supports many I/O daughter cards or shields for expanding external interfacing and control. These shields use 1 or 2 Micro-MaTch miniature connectors to interface to the VM800P main module. Users will be able to purchase shields from FTDI Chip in the coming months, or alternatively can build their own shield for specific applications.

The VM800P series of modules support 3 different LCD panel size options and are designed for industrial or commercial environments with precision fitted bezels in either black (-BK) or pearl (-PL).

- VM800P35A-xx is the 3.5" LCD
- VM800P43A-xx is the 4.3" LCD
- VM800P50A-xx is the 5.0" LCD

The VM800P utilises the FTDI FT800 Embedded Video Engine, EVE. Graphic, audio and touch features of the FT800 chip can be accessed with the VM800P. For a full list of the FT800's features please see the FT800 datasheet.

The VM800P module has the following features:

- FT800 for graphics, audio and touch processing
- ATMEGA328P system microcontroller operating at 5V/16MHz supporting Arduino libraries
- Touch screen LCD panel
- Backlight LED driver
- Audio power amplifier and micro speaker
- FT232R USB serial port for firmware upgrade
- Micro-SD socket for application storage, including 4GByte SD Card pre-loaded with sample applications
- Battery backed Real Time Clock
- 2x Micro-MaTch miniature connectors for daughter card expansion
- 5V power supply from micro-USB or battery connector
- Precision fitted bezel in black(-BK) or pearl (-PL)

Neither the whole nor any part of the information contained in, or the product described in this manual, may be adapted or reproduced in any material or electronic form without the prior written consent of the copyright holder. This product and its documentation are supplied on an as-is basis and no warranty as to their suitability for any particular purpose is either made or implied. Future Technology Devices International Ltd will not accept any claim for damages howsoever arising as a result of use or failure of this product. Your statutory rights are not affected. This product or any variant of it is not intended for use in any medical appliance, device or system in which the failure of the product might reasonably be expected to result in personal injury. This document provides preliminary information that may be subject to change without notice. No freedom to use patents or other intellectual property rights is implied by the publication of this document. Future Technology Devices International Ltd, Unit 1, 2 Seaward Place, Centurion Business Park, Glasgow G41 1HH United Kingdom. Scotland Registered Company Number: SC136640

1 Ordering Information

Part No.	Description
VM800P35A-BK	FT800 Display System, ATMEG328P @ 5V/16MHz, Micro-SD socket, 3.5" 320x240 resolution TFT LCD with resistive touch panel, black case
VM800P43A-BK	FT800 Display System, ATMEG328P @ 5V/16MHz, Micro-SD socket, 4.3" 480x272 resolution TFT LCD with resistive touch panel, black case
VM800P50A-BK	FT800 Display System, ATMEG328P @ 5V/16MHz, Micro-SD socket, 5.0" 480x272 resolution TFT LCD with resistive touch panel, black case
VM800P35A-PL	FT800 Display System, ATMEG328P @ 5V/16MHz, Micro-SD socket, 3.5" 320x240 resolution TFT LCD with resistive touch panel, pearl case
VM800P43A-PL	FT800 Display System, ATMEG328P @ 5V/16MHz, Micro-SD socket, 4.3" 480x272 resolution TFT LCD with resistive touch panel, pearl case
VM800P50A-PL	FT800 Display System, ATMEG328P @ 5V/16MHz, Micro-SD socket, 5.0" 480x272 resolution TFT LCD with resistive touch panel, pearl case
ACCESSORIES	
VA800A-PROG	Accessory - PLUS Production Programmer for ATMEGA328P inc Tag Connect TC2030-IDC-FP cable
VA-PSU-UK1	Accessory - UK Model 5V/1A USB Power Supply (Mfr # JX-B0520C-1-B)
VA-PSU-US1	Accessory - US Model 5V/1A USB Power Supply (Mfr # JX-B0520B-1-B)
VA-PSU-EU1	Accessory - EU Model 5V/1A USB Power Supply (Mfr # JX-B0520A-1-B)
VA-FC-1M-BKW	Accessory - Flat USB A to Micro B Cable 1M- Black and White
VA-FC-1M-BLW	Accessory - Flat USB A to Micro B Cable 1M- Blue and White
VA-FC-STYLUS1	Accessory - Resistive Touch Screen Pen Stylus

Table 1.1 VM800P & Accessory Ordering Information

Table of Contents

1	Ordering Information.....	1
2	Hardware Description	4
2.1	Physical Description	5
2.1.1	Dimensions.....	5
2.1.2	Connectors and Jumpers.....	6
2.1.3	CN1 - 2-pin power connector.....	6
2.1.4	CN2 – Micro USB Receptacle	7
2.1.5	J2 – Audio Selection	7
2.1.6	J5 – Expansion Connector for I/O Daughter Card	7
2.1.7	J6 - Expansion Connector for Comm Daughter Card	9
2.1.8	JP1 – Audio Amplifier Power Selection	9
2.1.9	SW1 – Power Source Selection	10
2.1.10	JP4 – USB Power Selection.....	10
2.2	Board Schematics.....	11
3	Hardware Setup Guide.....	14
3.1	Power Configuration	14
4	Arduino® Setup.....	15
4.1	Hardware Setup	15
4.2	Software Setup.....	15
5	Assembling the Bezel and Panel Mounting	18
5.1	Dimensions for 3.5” Bezel.....	19
5.2	Dimensions for 4.3” Bezel.....	20
5.3	Dimensions for 5.0” Bezel.....	21
6	Specifications	22
6.1	LCD Optical Specifications for 3.5” Panel.....	22
6.2	LCD Optical Specifications for 4.3” Panel.....	23
6.3	LCD Optical Specifications for 5.0” Panel.....	24
7	Contact Information.....	25
	Appendix A – References	26



Document References.....	26
Acronyms and Abbreviations.....	26
Appendix B – List of Tables & Figures.....	27
List of Tables.....	27
List of Figures.....	27
Appendix C – Revision History.....	28

2 Hardware Description



Figure 2.1 VM800P35A Module Profile 3.5" Display Version



Figure 2.2 VM800P43A Module Profile 4.3" Display Version



Figure 2.3 VM800P50A Module Profile 5.0" Display Version

NOTE: The above modules are also available with pearl coloured bezels.

The VM800P module is available for different LCD sizes: 3.5", 4.3" or 5".

Each VM800P module is assembled with following parts:

- VM800PxxA PCB board
- LCD panel with touch screen
- Bezel

The main functions of the VM800PxxA PCB board are as follows:

- FT800 EVE for graphic, audio and touch control
- ATMEGA328P microcontroller operating at 5V and 16MHz, controlling the FT800 and other peripheral interfaces
- 3 stage audio filter
- 8Ω micro speaker to work with on-board audio amplifier
- Jumper selection allowing audio line out option
- LCD backlight LED driver
- Real Time Clock(RTC) with button battery

- USB interface for power supply and firmware programming
- 2-pin JST connector for alternative power source
- 3.3V regulator: takes 5V input and outputs 3.3V for on-board circuits
- 2x Micro-MaTch miniature connectors for various daughter card expansion
- SD Card Socket (4GByte card supplied with module)

2.1 Physical Description

The VM800P module dimensions are illustrated in **Figure 2.4** and **Figure 2.5**.

2.1.1 Dimensions

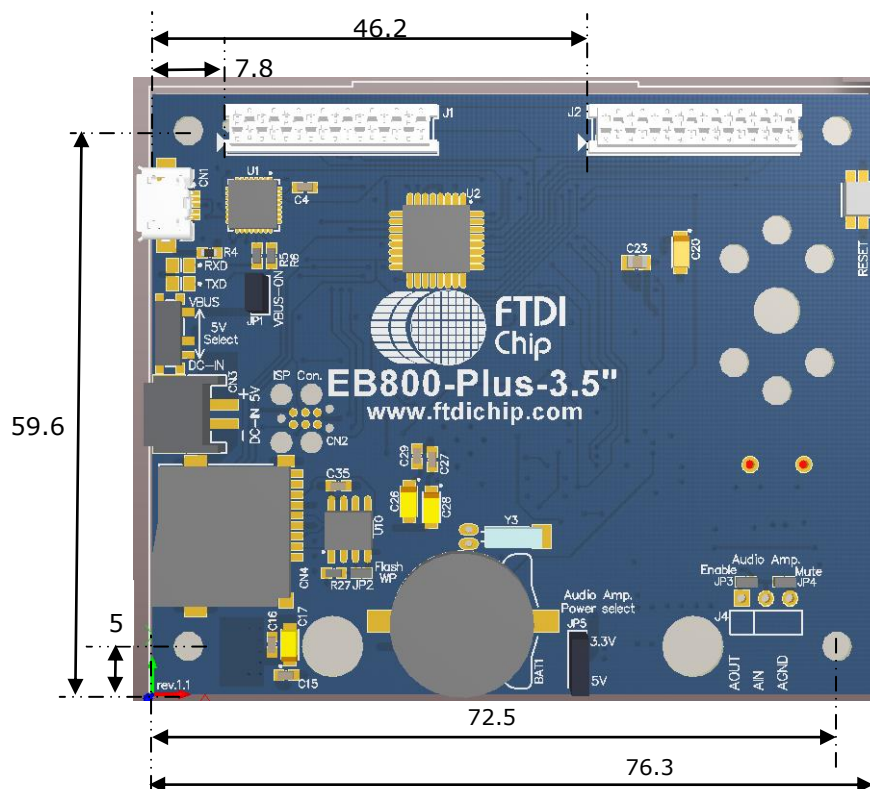

Figure 2.4 VM800P35A Dimensions (Top view)

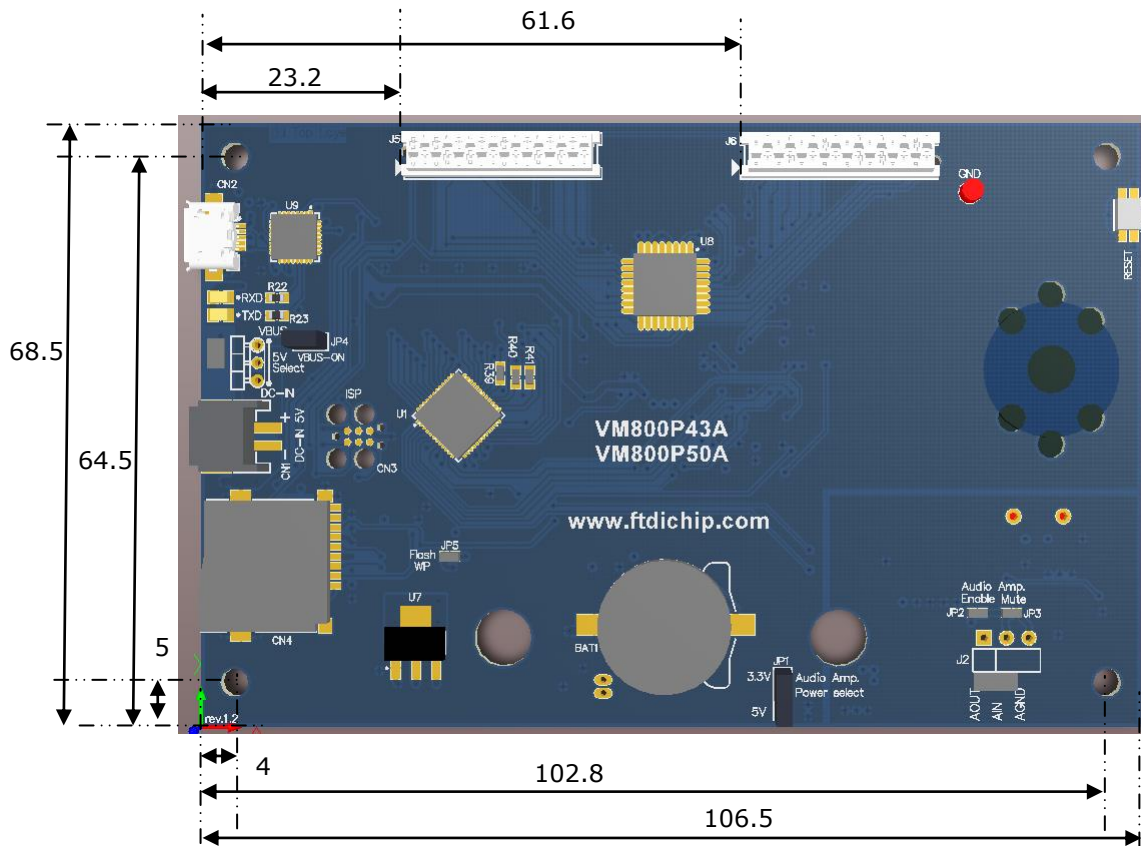

Figure 2.5 VM800P43A/VM800P50A Dimensions (Top view)

±0.50mm Tolerance

All dimensions are in mm

2.1.2 Connectors and Jumpers

Connectors and jumpers are described in the following sections.

2.1.3 CN1 - 2-pin power connector

Pin No.	Name	Type	Description
1	VCC	P	5V DC power supply
2	GND	P	Ground

Table 2.1 CN1 - Power Pin-out

2.1.4 CN2 – Micro USB Receptacle

Pin No.	Name	Type	Description
1	VBUS	P	5V power supply
2	D-	IO	USB D- line
3	D+	IO	USB D+ line
4	NC	NA	No connection
5	GND	P	Ground

Table 2.2 CN2 – Micro USB Pin-out
2.1.5 J2 – Audio Selection

Select between audio line-out or connection to the power amplifier.

Jumper position	Description
Short pin 1-2	Audio amp enabled (default)
Short pin 2-3	Audio amp mute, Audio lineout on pin 1

Table 2.3 J2 – Audio Options
2.1.6 J5 – Expansion Connector for I/O Daughter Card

This 16-pin Micro-MaTch miniature connector provides ATmega328P SPI/I²C/IO control to the daughter card. 5V and 3.3V power supplies are also available.

Pin No.	Name	Type	Description
1	SCK	O	SPI Clock output
2	MOSI	O	SPI Master Out Slave in
3	MISO	I	SPI Master In Slave out
4	IO7	O	SPI slave select
5	INT0	I	Interrupt input from DC
6	IO6	O	Active LOW reset output to DC
7	AD4	IO	I ² C SDA data input/output
8	AD5	O	I ² C SCL clock output
9	3V3	P	3.3V power supply to DC
10	5V	P	5V power supply to DC
11	GND	P	Ground

Pin No.	Name	Type	Description
12	RST#	O	System reset output
13	IO5	IO	GPIO
14	AD0	IO	GPIO
15	AD7	AI	ADC input
16	AD6	AI	ADC input

Table 2.4 J5 - I/O Expansion Connector Pin-out

2.1.7 J6 - Expansion Connector for Comm Daughter Card

This 16-pin Micro MaTch Miniature connector provides ATmega328P SPI/I²C/IO control to the daughter card. 5V and 3.3V power supplies are also available.

Pin No.	Name	Type	Description
1	SCK	O	SPI Clock output
2	MOSI	O	SPI Master Out Slave in
3	MISO	I	SPI Master In Slave out
4	SS	O	SPI salve select
5	INT0	I	Interrupt input from DC
6	IO6	O	Active LOW reset output to DC
7	AD4	IO	I ² C SDA data input/output
8	AD5	O	I ² C SCL clock output
9	3V3	P	3.3V power supply to DC
10	5V	P	5V power supply to DC
11	GND	P	Ground
12	RST#	O	System reset output
13	AD1	IO	GPIO
14	IO4	IO	GPIO
15	AD3	AI	GPIO
16	AD2	AI	GPIO

Table 2.5 J5 - Communication Expansion Connector Pin-out

2.1.8 JP1 – Audio Amplifier Power Selection

This jumper provides the option to select the power supply voltage for the on-board power amplifier.

Jumper position	Description
Short pin 1-2	3.3V selected (default)
Short pin 2-3	5V selected

Table 2.6 JP1 - Audio Amplifier Power Pin Options

NOTE: This needs to be configured before audio can be heard. Default is 3.3V. Select 5V to increase the maximum volume for the speaker.

2.1.9 SW1 – Power Source Selection

Jumper position	Description
Short pin 1-2	Board power from CN1
Short pin 2-3	Board power from CN2 (default)

Table 2.7 SW1 - Power Source Selection**2.1.10 JP4 – USB Power Selection**

Jumper position	Description
Open	Enable USB power to application circuits when FT232R is enumerated (Default). USB power will be turned off during USB suspend
Short	USB power always enabled

Table 2.8 JP4 - USB Power Selection

2.2 Board Schematics

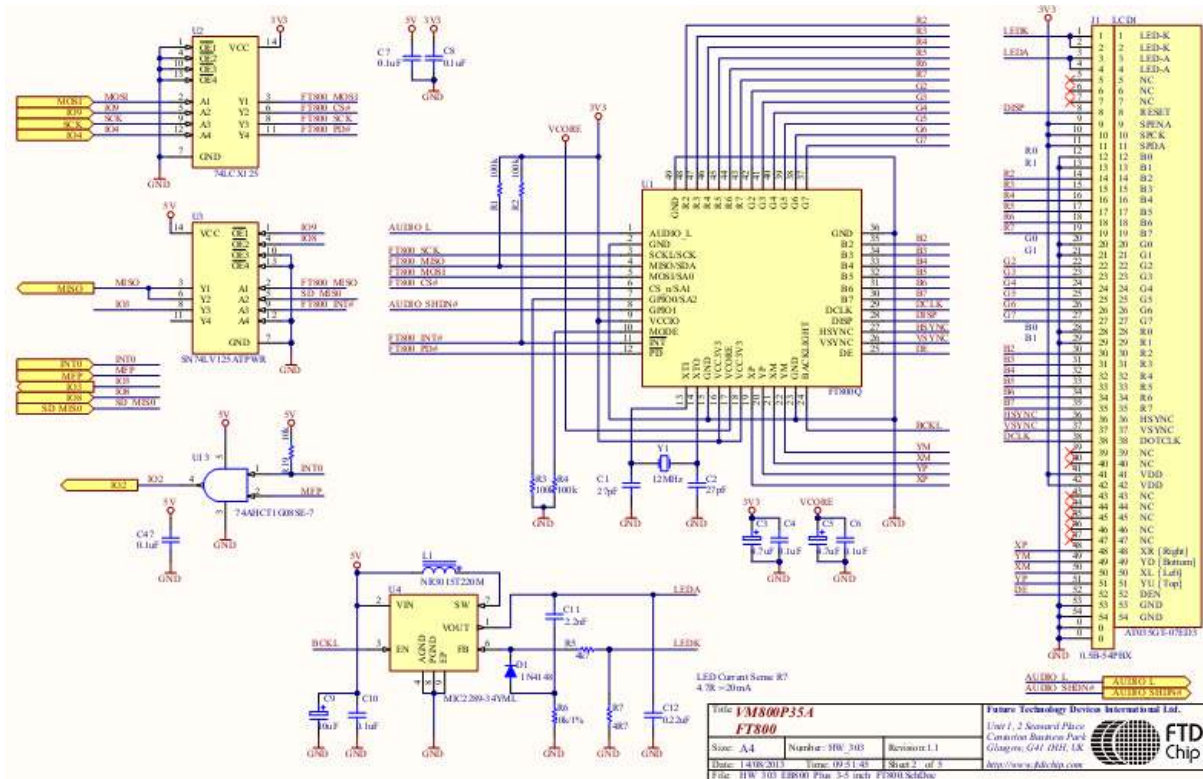

Figure 2.6 VM800P35A FT800 and LCD Interface

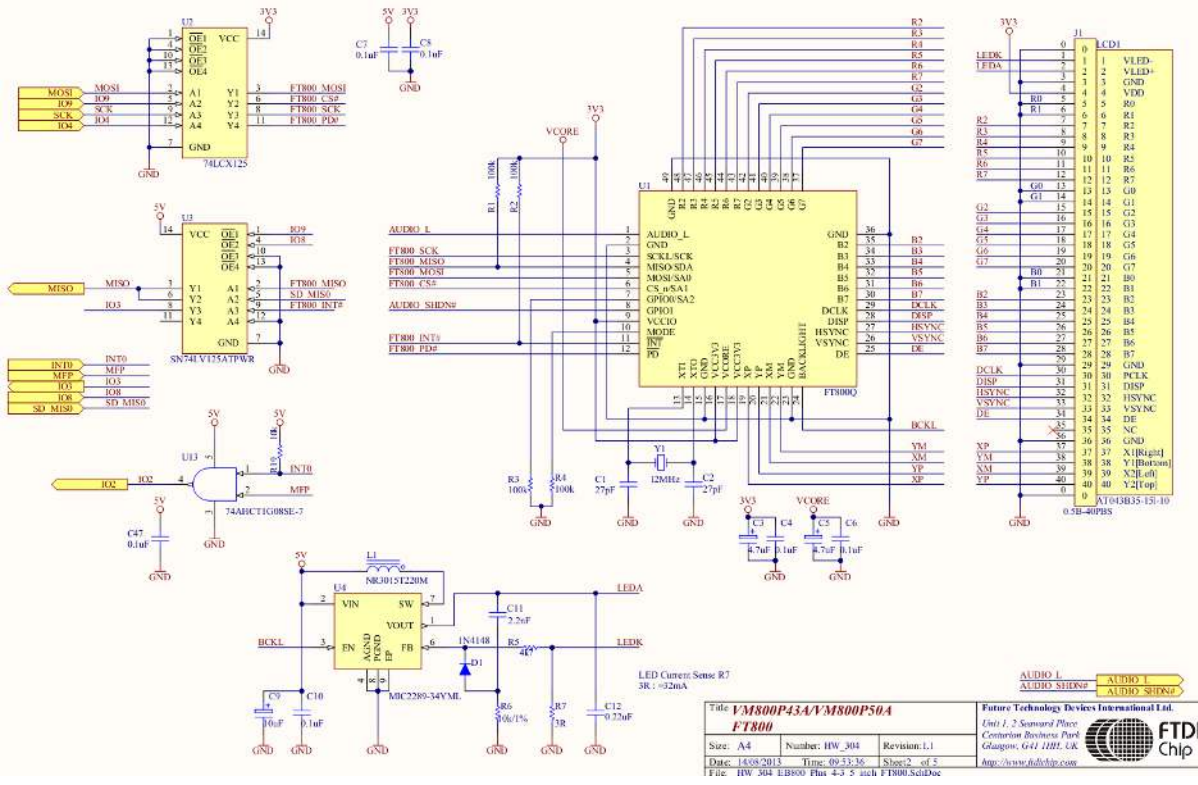

Figure 2.7 VM800P43A/VM800P50A FT800 and LCD Interface

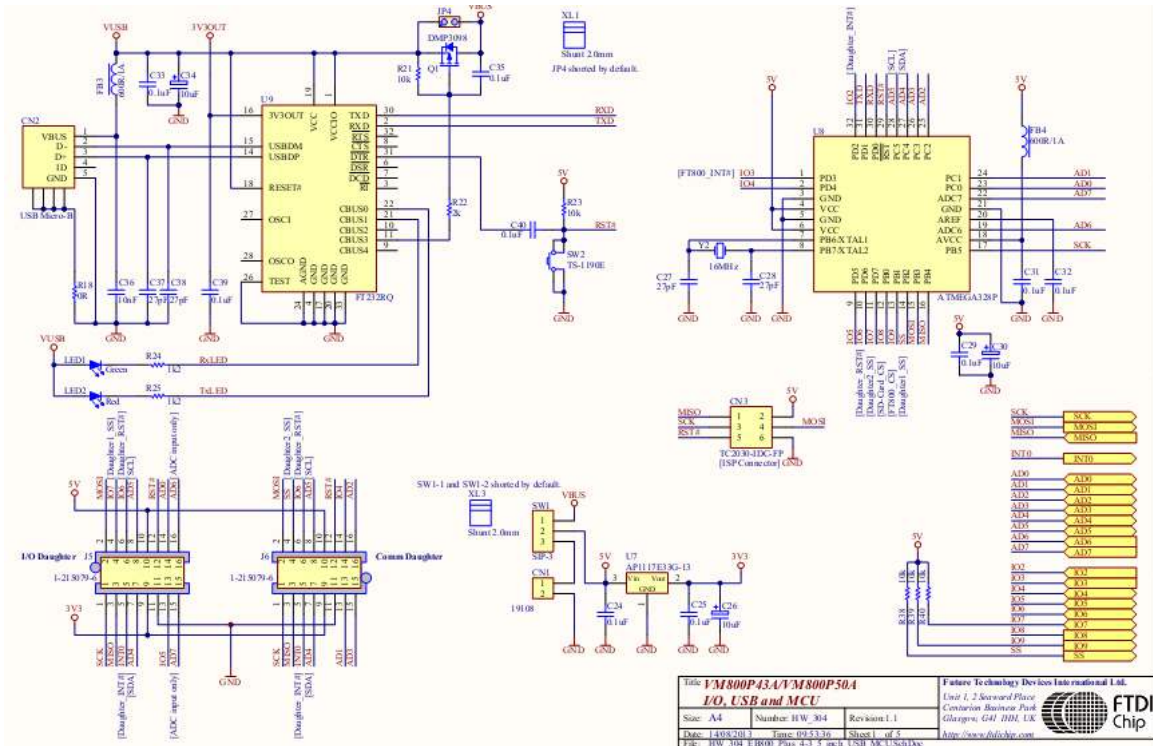

Figure 2.8 VM800PxxA MCU, USB and I/O

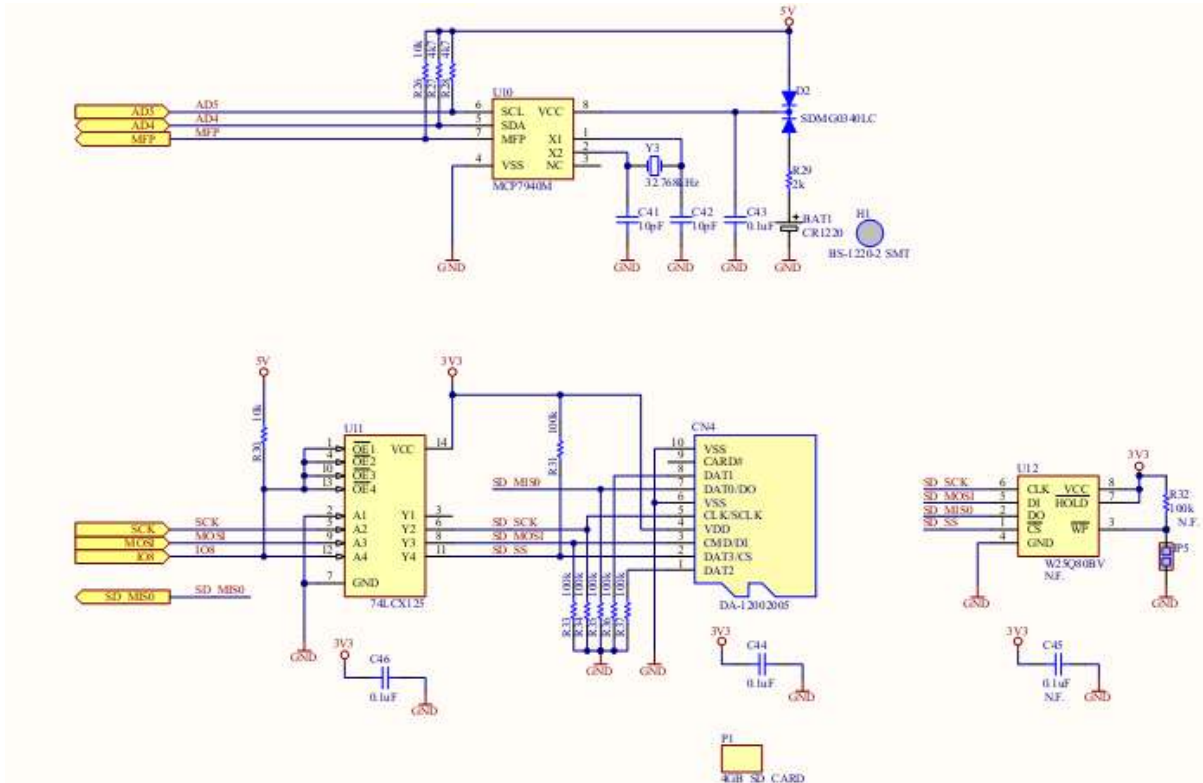

Figure 2.9 VM800PxxA SD-Card, Flash and RTC

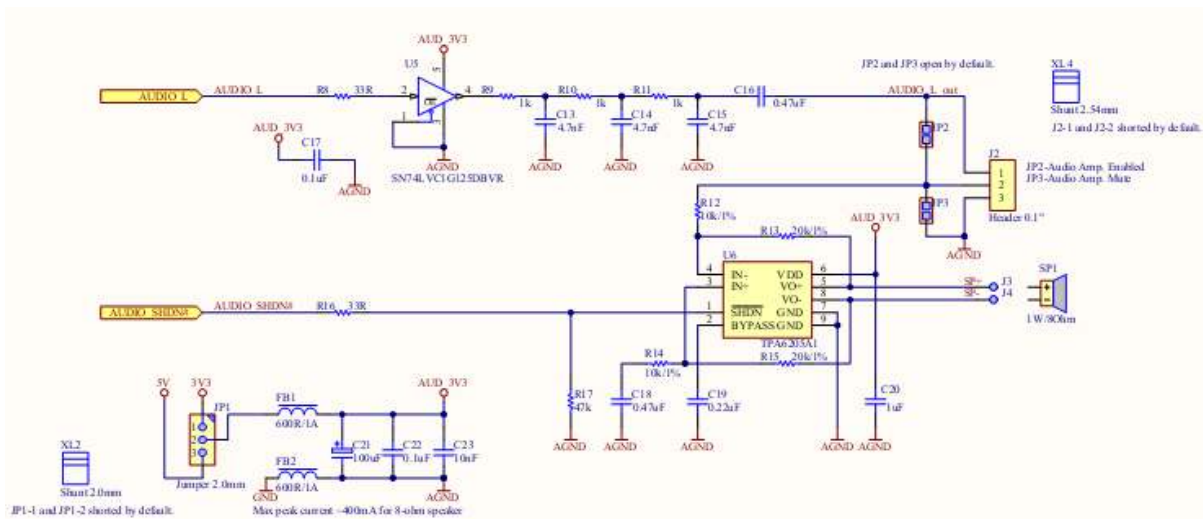

Figure 2.10 VM800PxxA Audio

3 Hardware Setup Guide

3.1 Power Configuration

There are 2 methods of powering the VM800P board.

- 1) USB Power(5V) - Connect USB power through micro-USB cable to CN2
- 2) DC IN(5V) - Connect 5V to CN1

The following table summarizes how to power the VM800P board using the various methods.

Power Method	CN1	CN2	SW1
USB Power	N/C	5V	Short pin 2-3 (default)
DC IN(5V)	5V	5V	Short pin 1-2

Table 3.1 Board Power Configuration

4 Arduino® Setup

FTDI provides sample source code, sample application notes and a ready to run demo based on the Arduino® platform. Detailed information can be found at:

http://www.ftdichip.com/Support/Documents/AppNotes/AN_318_Arduino_Library_for_FT800_Series.pdf

http://www.ftdichip.com/Support/Documents/AppNotes/AN_275_FT800_Example_with_Arduino.pdf

http://www.ftdichip.com/Support/Documents/AppNotes/AN_246%20VM800CB_SampleApp_Arduino_Introduction.pdf

4.1 Hardware Setup

- Connect a USB cable (suggest FTDI accessory VA-FC-1M-BKW or VA-FC-1M-BLW) from the VM800P USB port CN2 to the PC USB host port or self-powered hub port.
- The PC will supply power to the VM800P after the FTDI FT232R driver is properly loaded and the USB host completes USB device configuration.

4.2 Software Setup

The arduino code can be downloaded from the Arduino IDE to the ATMEGA328P through the USB connector CN2 connected to the PC. The USB connector CN2 is also used to display debug output from the ATMEGA328P to the PC terminal application.

Default sample code is downloaded to the ATMEGA328P during the VM800P module manufacturing. When the VM800P is connected to the PC through the USB connector CN2, the VM800P is powered up and the sample code is functional with the demo applications.

- Download the Arduino IDE from <http://arduino.cc/en/main/software>.
- Install the Arduino IDE
- Open the Arduino IDE
- Open the FT800 sample project to be downloaded to the VM800P

(Examples are available from:

http://www.ftdichip.com/Support/SoftwareExamples/FT800_Projects.htm

Or you may have developed your own code)

- Select the Tools->Board-> Arduino Pro or Pro Mini(5V, 16MHz) w/ATmega328 as shown in Fig 4.1.
- Select the Tools->Serial Port->COMxx corresponding to the VM800P as shown in Fig 4.2.
- Click the Upload button as shown in Fig 4.3. This will upload the FT800 sample to the VM800P.

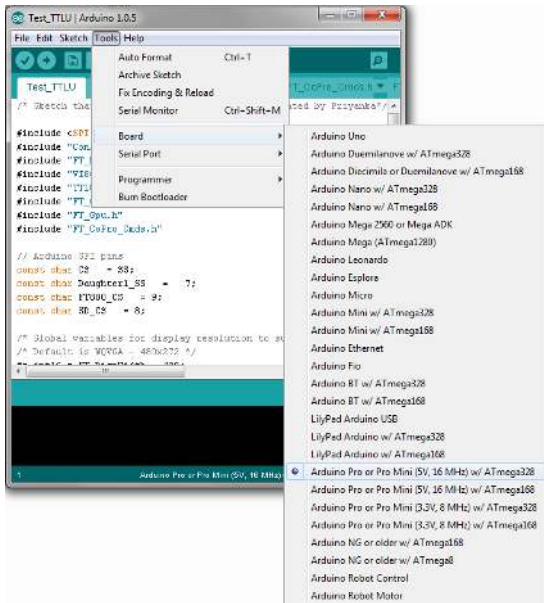

Figure 4.1 Select Board

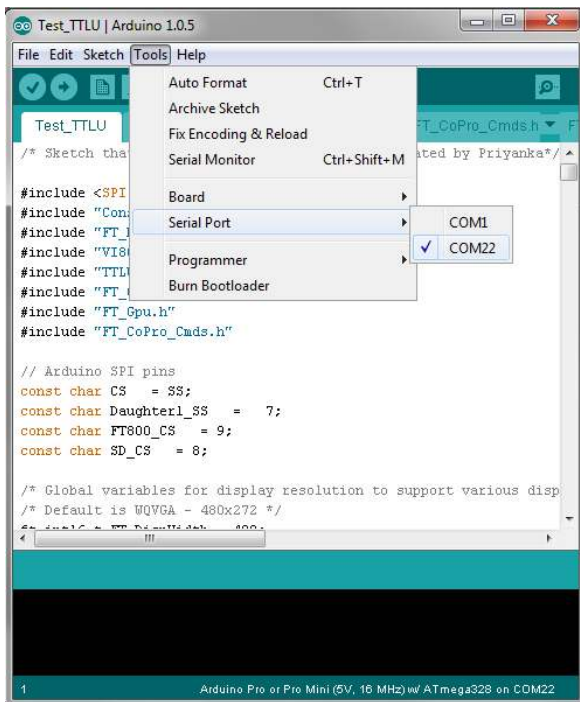

Figure 4.2 Select Serial Port

(NOTE: Your device may not be COM22 as shown. Select the COM port you have installed)

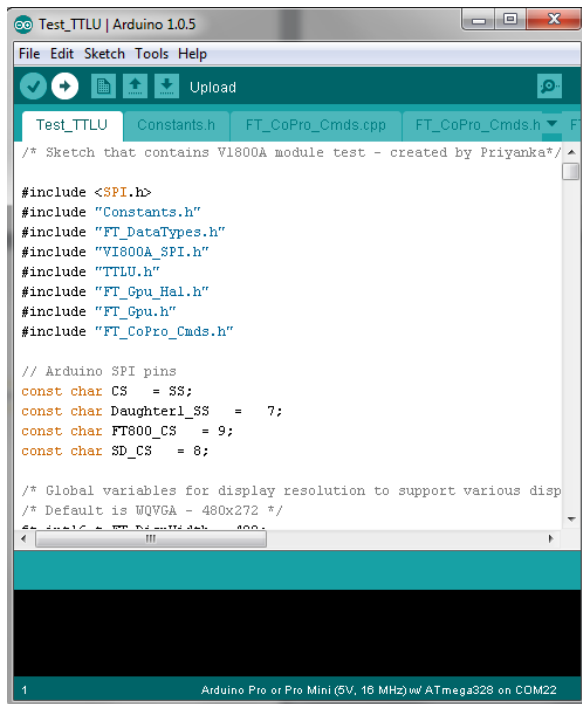

Figure 4.3 Click Upload Button

5 Assembling the Bezel and Panel Mounting

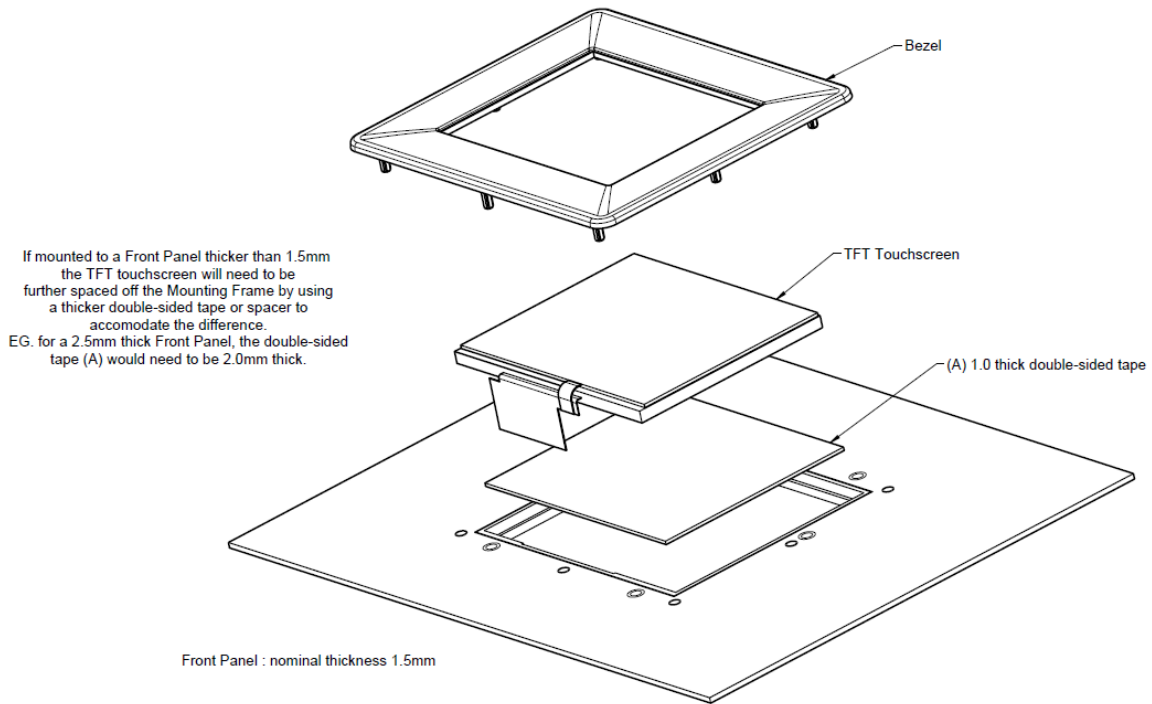

Figure 5.1 VM800P Panel Mount (Front view)

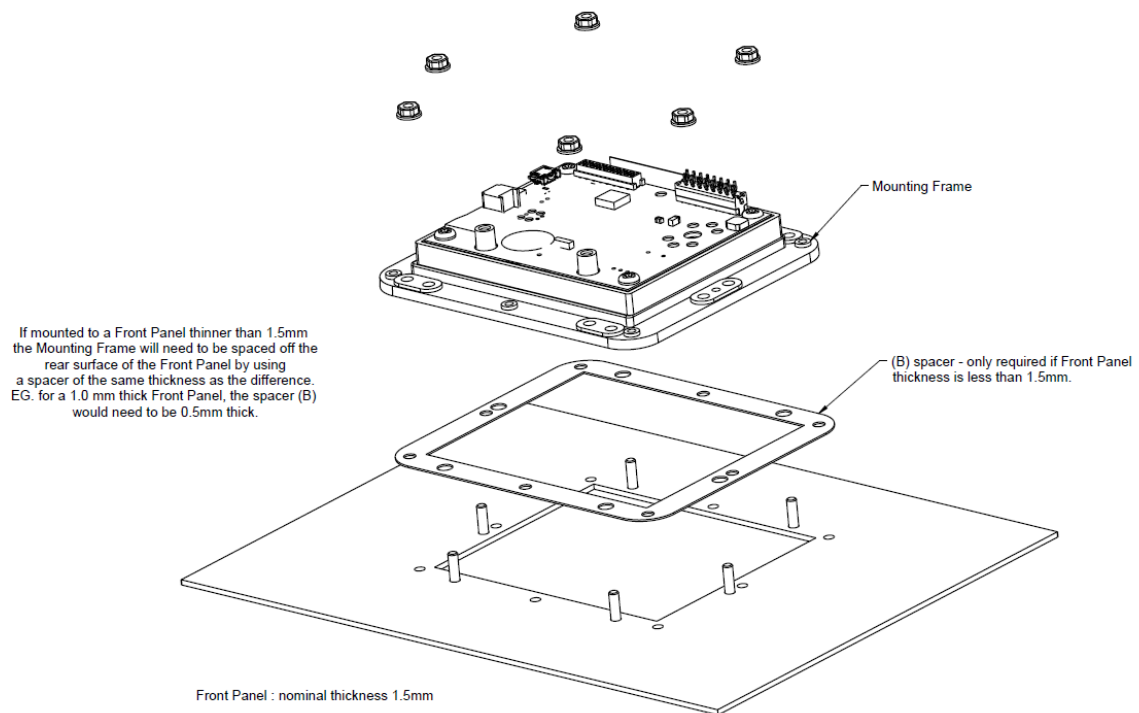
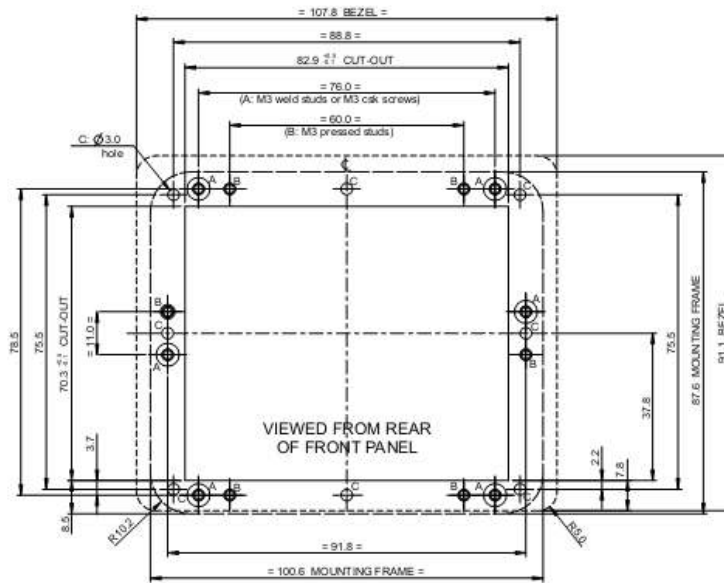

Figure 5.2 VM800P Panel Mount (Rear view)

5.1 Dimensions for 3.5" Bezel

The TFT Touchscreen Mounting Frame is designed to mount to a 1.5mm thick Front Panel. If mounted to a Front Panel thicker than 1.5mm, longer mounting studs or screws should be used to accommodate the difference.

The Mounting Frame has been designed to work with projection welded studs or csk screws 'A' or press studs 'B'. For a 1.5mm thick Front Panel use -
M3 x 8 long weld studs,
M3 x 10 long countersunk screws or
M3 x 10 long pressed studs



When using countersunk screws to assemble the Mounting Frame, the screws should be located at the 'A' position

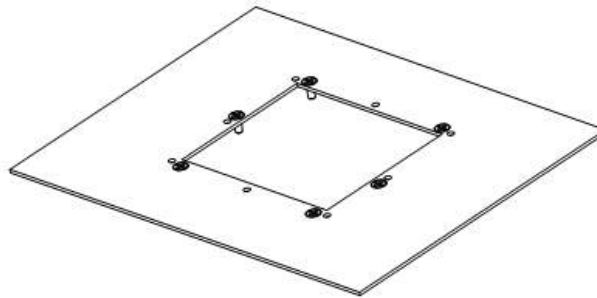

Figure 5.3 VM800P 3.5" panel mount dimensions

5.2 Dimensions for 4.3" Bezel

The TFT Touchscreen Mounting Frame is designed to mount to a 1.5mm thick Front Panel. If mounted to a Front Panel thicker than 1.5mm, longer mounting studs or screws should be used to accommodate the difference.

The Mounting Frame has been designed to work with projection welded studs or csk screws 'A' or press studs 'B'. For a 1.5mm thick Front Panel use - M3 x 8 long weld studs, M3 x 10 long countersunk screws or M3 x 10 long pressed studs

When using countersunk screws to assemble the Mounting Frame, the screws should be located at the 'A' position

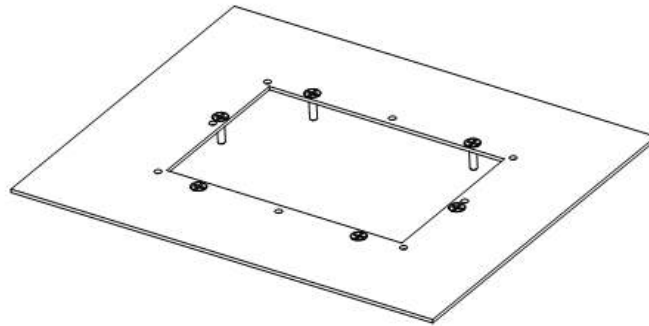
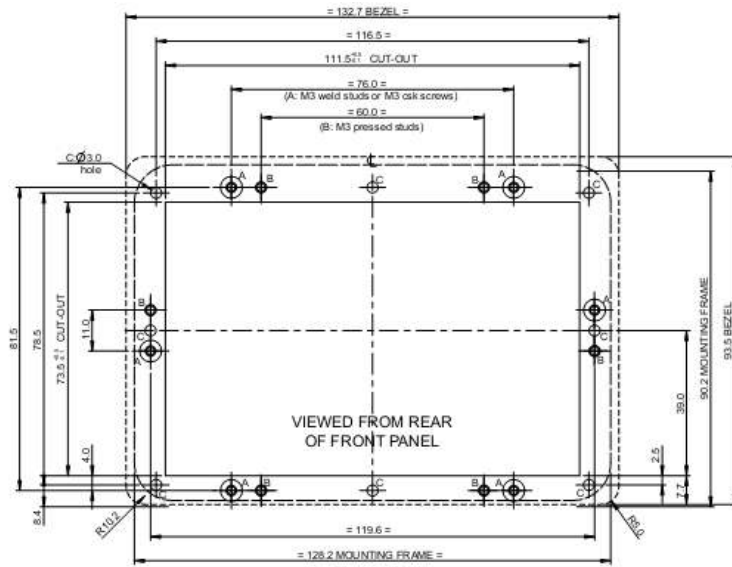

Figure 5.4 VM800P 4.3" panel mount dimensions

5.3 Dimensions for 5.0" Bezel

The TFT Touchscreen Mounting Frame is designed to mount to a 1.5mm thick Front Panel. If mounted to a Front Panel thicker than 1.5mm, longer mounting studs or screws should be used to accommodate the difference.

The Mounting Frame has been designed to work with projection welded studs or csk screws 'A' or press studs 'B'. For a 1.5mm thick Front Panel use -
M3 x 8 long weld studs,
M3 x 10 long countersunk screws or
M3 x 10 long pressed studs

When using countersunk screws to assemble the Mounting Frame, the screws should be located at the 'A' position

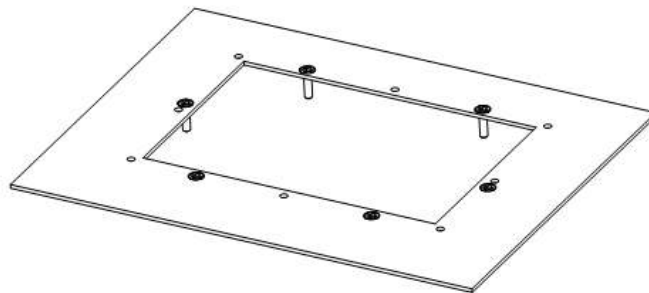
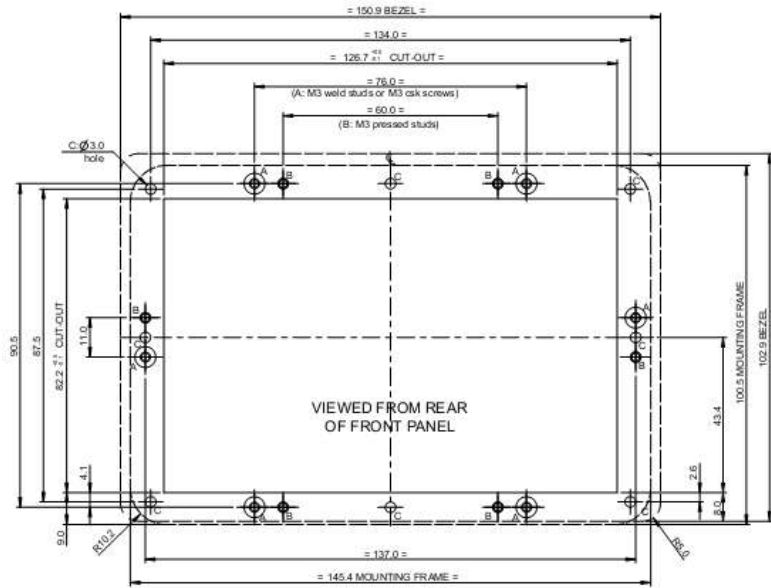

Figure 5.5 VM800P 5.0" panel mount dimensions

6 Specifications

6.1 LCD Optical Specifications for 3.5" Panel

Item	Symbol	Condition	Min	Typ.	Max.	Unit
View Angles	θT	$CR \geq 10$	30	40		Degree
	θB		50	60		
	θL		50	60		
	θR		50	60		
Contrast Ratio	CR	$\theta = 0^\circ$		350		
Response Time	Ton	25°C		25	40	ms
	Toff					
Chromaticity	White	x	0.260	0.310	0.360	
		y	0.283	0.333	0.383	
	RED	x	0.574	0.624	0.674	
		y	0.318	0.368	0.418	
	GREEN	x	0.300	0.350	0.400	
		y	0.500	0.550	0.600	
	BLUE	x	0.093	0.143	0.193	
		y	0.069	0.119	0.169	
Uniformity	U		75	80		%
NTSC				50		%
Luminance	L			500		cd/m ²

Figure 6.1 3.5" TFT Optical Specifications

6.2 LCD Optical Specifications for 4.3" Panel

Item	Symbol	Condition	Min.	Typ.	Max.	Unit
Brightness	Bp	$\theta=0^\circ$	-	350	-	Cd/m ²
Uniformity	ΔBp	$\Phi=0^\circ$	70	80	-	%
Viewing Angle	3:00	$Cr \geq 10$	-	45	-	Deg
	6:00		-	20	-	
	9:00		-	45	-	
	12:00		-	40	-	
Contrast Ratio	Cr	$\theta=0^\circ$ $\Phi=0^\circ$	350	500	-	-
Response Time	T _r		-	10	-	ms
	T _f		-	10	-	ms
Color of CIE Coordinate	W	x	$\theta=0^\circ$ $\Phi=0^\circ$	0.28	-	-
		y		0.33	-	-
	R	x		0.51	-	-
		y		0.34	-	-
	G	x		0.31	-	-
		y		0.56	-	-
	B	x		0.15	-	-
		y		0.14	-	-
NTSC Ratio	S	50	60	-	%	

Figure 6.2 4.3" TFT Optical Specifications

6.3 LCD Optical Specifications for 5.0" Panel

Item	Symbol	Condition	Min.	Typ.	Max.	Unit
Brightness	Bp	$\theta=0^\circ$	200	250	-	Cd/m ²
Uniformity	ΔBp	$\Phi=0^\circ$	70	80	-	%
Viewing Angle	3:00	$Cr \geq 10$	-	45	-	Deg
	6:00		-	25	-	
	9:00		-	45	-	
	12:00		-	45	-	
Contrast Ratio	Cr	$\theta=0^\circ$	350	500	-	-
Response Time	T_r	$\Phi=0^\circ$	-	10	-	ms
	T_f		-	10	-	ms
Color of CIE Coordinate	W	x	-	0.28	-	-
		y	-	0.33	-	-
	R	x	-	0.51	-	-
		y	-	0.34	-	-
	G	x	-	0.31	-	-
		y	-	0.56	-	-
	B	x	-	0.15	-	-
		y	-	0.14	-	-
NTSC Ratio	S	$\theta=0^\circ$	50	60	-	%

Figure 6.3 5.0" TFT Optical Specifications

7 Contact Information

Head Office – Glasgow, UK

Future Technology Devices International Limited
Unit 1, 2 Seaward Place, Centurion Business Park
Glasgow G41 1HH
United Kingdom
Tel: +44 (0) 141 429 2777
Fax: +44 (0) 141 429 2758

E-mail (Sales) sales1@ftdichip.com
E-mail (Support) support1@ftdichip.com
E-mail (General Enquiries) admin1@ftdichip.com

Branch Office – Tigard, Oregon, USA

Future Technology Devices International Limited
(USA)
7130 SW Fir Loop
Tigard, OR 97223-8160
USA
Tel: +1 (503) 547 0988
Fax: +1 (503) 547 0987

E-Mail (Sales) us.sales@ftdichip.com
E-Mail (Support) us.support@ftdichip.com
E-Mail (General Enquiries) us.admin@ftdichip.com

Branch Office – Taipei, Taiwan

Future Technology Devices International Limited
(Taiwan)
2F, No. 516, Sec. 1, NeiHu Road
Taipei 114
Taiwan, R.O.C.
Tel: +886 (0) 2 8791 3570
Fax: +886 (0) 2 8791 3576

E-mail (Sales) tw.sales1@ftdichip.com
E-mail (Support) tw.support1@ftdichip.com
E-mail (General Enquiries) tw.admin1@ftdichip.com

Branch Office – Shanghai, China

Future Technology Devices International Limited
(China)
Room 1103, No. 666 West Huaihai Road,
Shanghai, 200052
China
Tel: +86 21 62351596
Fax: +86 21 62351595

E-mail (Sales) cn.sales@ftdichip.com
E-mail (Support) cn.support@ftdichip.com
E-mail (General Enquiries) cn.admin@ftdichip.com

Web Site

<http://ftdichip.com>

System and equipment manufacturers and designers are responsible to ensure that their systems, and any Future Technology Devices International Ltd (FTDI) devices incorporated in their systems, meet all applicable safety, regulatory and system-level performance requirements. All application-related information in this document (including application descriptions, suggested FTDI devices and other materials) is provided for reference only. While FTDI has taken care to assure it is accurate, this information is subject to customer confirmation, and FTDI disclaims all liability for system designs and for any applications assistance provided by FTDI. Use of FTDI devices in life support and/or safety applications is entirely at the user's risk, and the user agrees to defend, indemnify and hold harmless FTDI from any and all damages, claims, suits or expense resulting from such use. This document is subject to change without notice. No freedom to use patents or other intellectual property rights is implied by the publication of this document. Neither the whole nor any part of the information contained in, or the product described in this document, may be adapted or reproduced in any material or electronic form without the prior written consent of the copyright holder. Future Technology Devices International Ltd, Unit 1, 2 Seaward Place, Centurion Business Park, Glasgow G41 1HH, United Kingdom. Scotland Registered Company Number: SC136640

Appendix A – References

Document References

For module documentations, please refer to URL below:

<http://www.ftdichip.com/Products/modules/VM800P.html>

FT800 datasheet: [DS FT800 Embedded Video Engine](#)

FT800 software programming guide: [FT800 Programmer Guide](#)

AN_318: [Arduino Library for FT800 Series](#)

AN_275 : [FT800 Example with Android](#)

AN_246: [VM800CB SampleApp Arduino Introduction](#)

Acronyms and Abbreviations

Terms	Description
IO	Input Output
I ² C	Inter Integrated Circuit
LCD	Liquid Crystal Display
RTC	Real Time Clock
SD CARD	Secure Digital Card
SPI	Serial Peripheral Interface
UART	Universal Asynchronous Receiver Transmitter
USB	Universal Serial Bus
USB-IF	USB Implementers Forum

Appendix B – List of Tables & Figures

List of Tables

Table 1.1 VM800P & Accessory Ordering Information.....	1
Table 2.1 CN1 - Power Pin-out.....	6
Table 2.2 CN2 – Micro USB Pin-out.....	7
Table 2.3 J2 – Audio Options	7
Table 2.4 J5 - I/O Expansion Connector Pin-out	8
Table 2.5 J5 - Communication Expansion Connector Pin-out.....	9
Table 2.6 JP1 - Audio Amplifier Power Pin Options.....	9
Table 2.7 SW1 - Power Source Selection.....	10
Table 2.8 JP4 - USB Power Selection	10
Table 3.1 Board Power Configuration	14

List of Figures

Figure 2.1 VM800P35A Module Profile 3.5" Display Version.....	4
Figure 2.2 VM800P43A Module Profile 4.3" Display Version.....	4
Figure 2.3 VM800P50A Module Profile 5.0" Display Version.....	4
Figure 2.4 VM800P35A Dimensions (Top view)	5
Figure 2.5 VM800P43A/VM800P50A Dimensions (Top view).....	6
Figure 2.6 VM800P35A FT800 and LCD Interface.....	11
Figure 2.7 VM800P43A/VM800P50A FT800 and LCD Interface.....	12
Figure 2.8 VM800PxxA MCU, USB and I/O	12
Figure 2.9 VM800PxxA SD-Card, Flash and RTC	13
Figure 2.10 VM800PxxA Audio	13
Figure 4.1 Select Board	16
Figure 4.2 Select Serial Port	16
Figure 4.3 Click Upload Button.....	17
Figure 5.1 VM800P Panel Mount (Front view).....	18
Figure 5.2 VM800P Panel Mount (Rear view).....	18
Figure 5.3 VM800P 3.5" panel mount dimensions	19
Figure 5.4 VM800P 4.3" panel mount dimensions	20
Figure 5.5 VM800P 5.0" panel mount dimensions	21
Figure 6.1 3.5" TFT Optical Specifications.....	22
Figure 6.2 4.3" TFT Optical Specifications.....	23
Figure 6.3 5.0" TFT Optical Specifications.....	24

Appendix C – Revision History

Document Title: VM800P Embedded Video Engine Plus Module Datasheet
Document Reference No.: FT_000989
Clearance No.: FTDI# 385
Product Page: <http://www.ftdichip.com/EVE.htm>
Document Feedback: [Send Feedback](#)

Revision	Changes	Date
1.0	Initial Release	2014-04-24
1.1	Updated Release	2014-05-27
1.2	Updated the optical characteristics for the 4.3" and 5" displays	2014-06-12