

INTRODUCTION

DESCRIPTION

The IN-PLUG® IPS101 is a special line-side switching controller which provides simple yet high performance active power factor correction. The IPS101 was optimized for electronic ballast compact SMPSs up to 300W that requires a minimum board area, reduced component count and high efficiency.

The PFC forces the SMPS to draw a current proportional to the instant AC line voltage in order to charge a storage capacitor thus resulting in excellent power factor and low line harmonics generation.

The output of the PFC is a regulated voltage which slightly exceeds the peak line voltage and is generally too high to be used as is. This is why a PFC is usually followed by a DC/DC converter, providing one or more isolated output(s) at the required voltage(s).

AAI offers the following solutions for the DC/DC converter:

- Flyback converters (see IPS10 series)
- Push-pull converters (see IPS201 controller)

Other ICs and discrete solutions can be used as well. More and more countries already impose PFC above 75W or soon will enforce this obligation.

In addition to the compliance with power factor and line harmonics regulations, using a PFC offers other advantages like:

- Reducing the utility bill by making the actual power drawn from the line almost equal to the apparent power paid to the utility company
- Allowing to draw more power from the wall outlet or line circuit breaker without exceeding the limits set by UL or other safety agencies.

FEATURES

- Simple and easy to use.
- High efficiency over 96% (in optimized designs)
- Minimum external component count for lowest cost.
- 3-input current-mode multiplier ensures outstanding performance at any line voltage and any load.
- Under voltage protection.
- Voltage error amplifier with provision for loop stability compensation.
- Cycle to cycle current limiting.
- Thermal shut-down.
- Capable of driving a broad range of power MOSFETs.
- Self oscillating at frequencies up to 300KHz

APPLICATIONS

- SMPS.
- Electronic ballast.

PIN CONFIGURATION: DIP-8 / SOIC-8

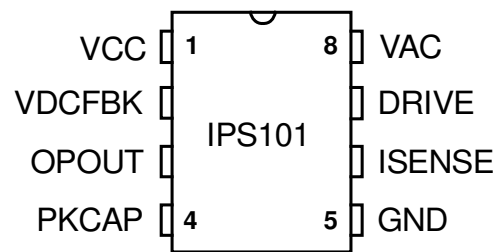

ORDERING INFORMATION

Part No.	ROHS / Pb-Free	Package	Temperature Range	
IPS101C-D	-G-LF	8-Pin PDIP	0°C to +70°C	Commercial
IPS101I-D	-G-LF	8-Pin PDIP	-40°C to +85°C	Industrial
IPS101C-SO	-G-LF	8-Pin SOIC	0°C to +70°C	Commercial
IPS101I-SO	-G-LF	8-Pin SOIC	-40°C to +85°C	Industrial

For detailed ordering information, see page 14

BASIC APPLICATION SCHEMATIC

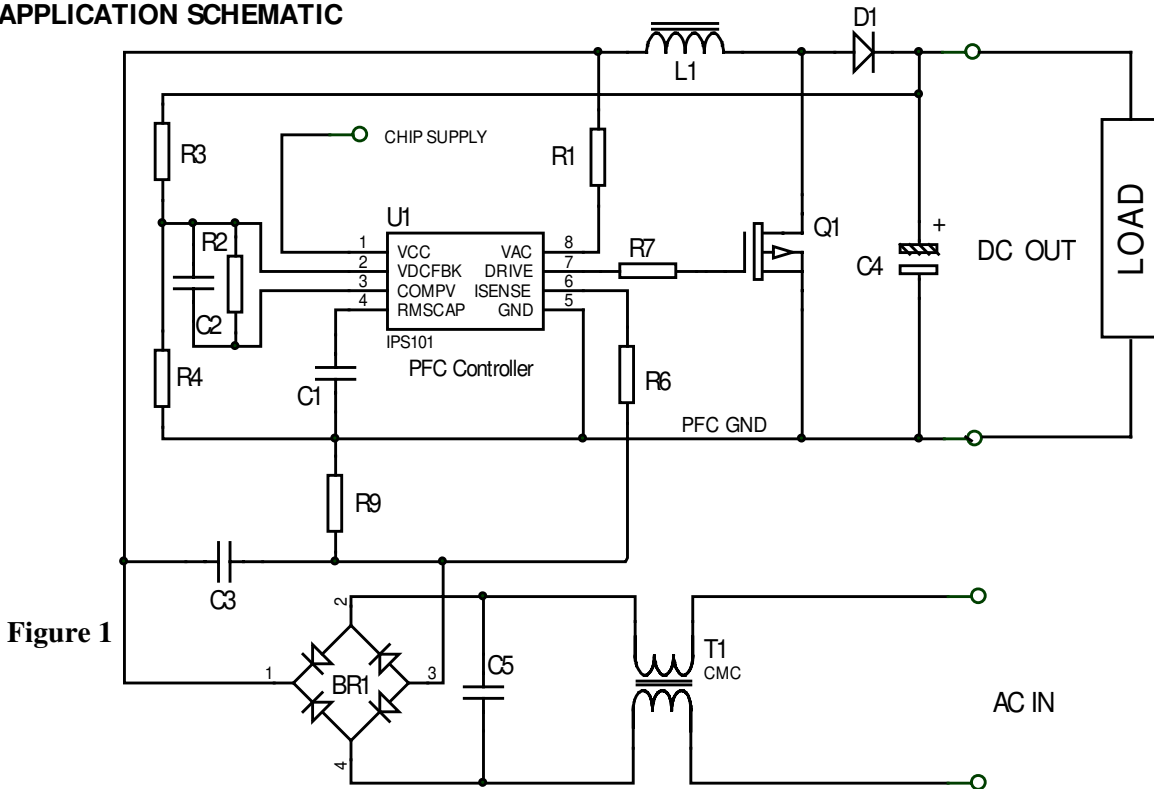

Figure 1

BASIC APPLICATION WITH DC/DC FEED-BACK CONTROL

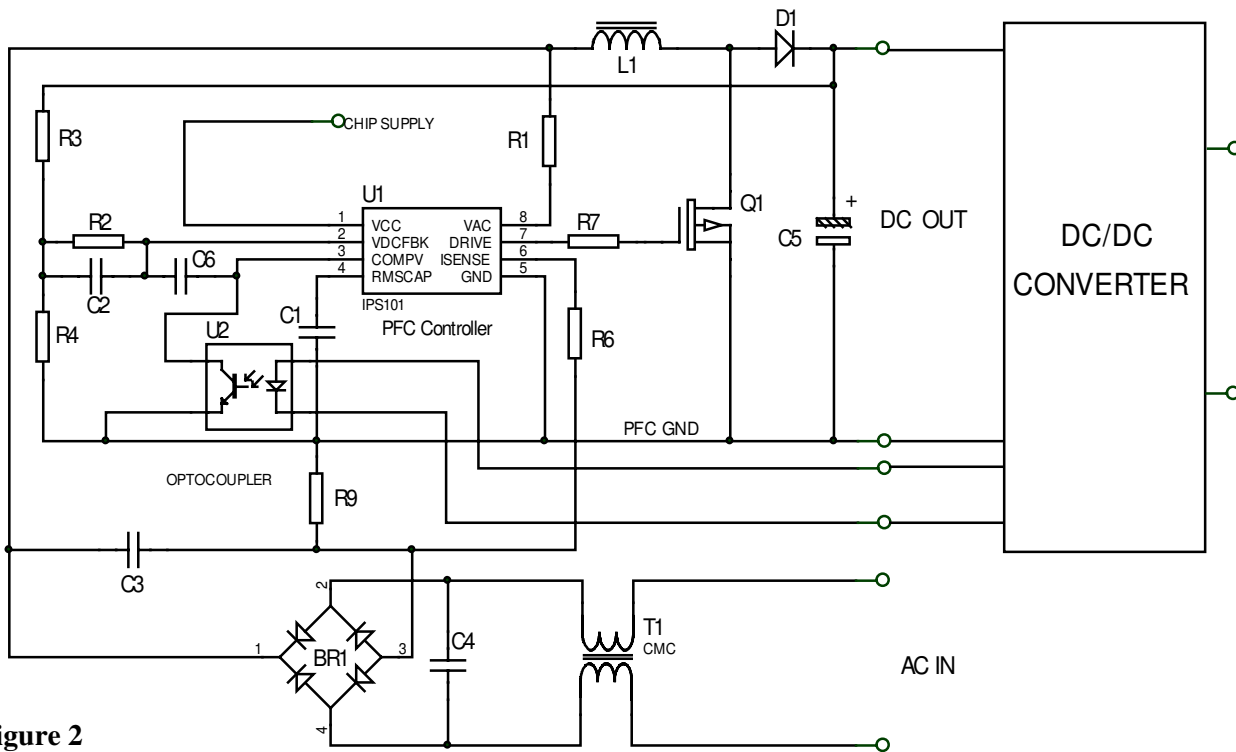

Figure 2

Note: This diagram displays a double feedback control. The resistor bridge R3/R4 can be set to safely guarantee a maximum output voltage while the feedback control signal from the DC/DC block through the optocoupler would manage the output voltage regulation.

FUNCTIONAL BLOCK DIAGRAM

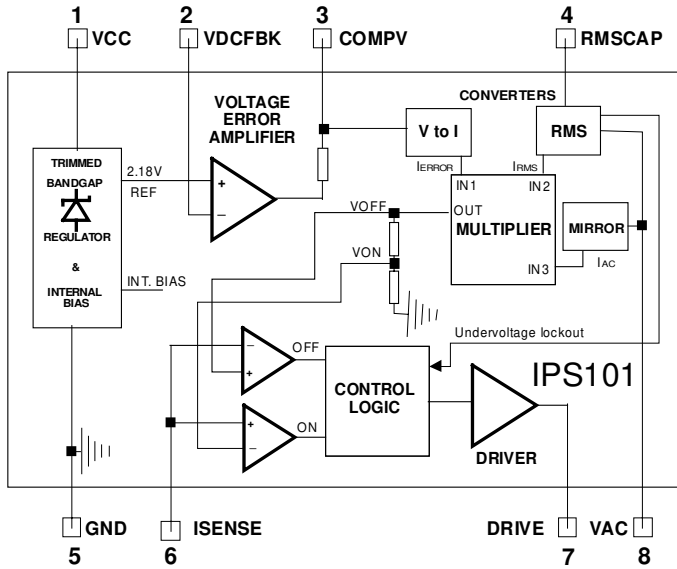

Figure 3

PIN DESCRIPTION

Number	Name	Description
1	VCC	IC supply pin. The circuit contains a shunt regulator that behaves like a 10V zener. During start-up the IC draws very little current. Operations start when the “zener” value is reached and stop should the VCC voltage becomes less than approximately 8V.
2	VDCFBK	Voltage feedback input pin. Negative feedback of the voltage error amplifier which positive input is internally connected to a 2.06V trimmed reference. It is used to regulate the voltage across the storage output capacitor to a value slightly above the maximum line peak voltage.
3	COMPV	Voltage loop compensation pin. This is the output of the voltage error amplifier and is used for loop feedback compensation purposes. Also used as an optional feedback loop to regulate the output of a DC/DC converter fed by the PFC controller (see Fig. 2)
4	RMSCAP	RMS capacitor pin. The capacitor connected between this pin & GND generates a current proportional to the RMS value of the AC line voltage which feeds the multiplier circuit to maintain the loop gain constant at different line voltages thus preventing loop instabilities which could occur with other arrangements.
5	GND	Ground pin. This pin must be connected to the PFC module ground.
6	ISENSE	Inductor current sensing pin. This pin is used to measure the current flowing through the inductor which is forced by the PFC controller to be proportional to the instant AC line voltage. The power MOSFET is automatically driven in a self-oscillating mode to restart a new cycle when the current in the inductor has dropped below half of its peak value.
7	DRIVE	MOSFET gate drive pin. The internal buffer connected to this pin can drive a broad variety of power MOSFETs and IGBTs. A series resistor is sometimes added to improve the EMI signature.
8	VAC	AC voltage pin. This pin is used to sense the instantaneous AC line voltage through a series resistor that performs a voltage to current conversion. The resulting current feeds the multiplier in order to force the peak current in the inductor to be proportional to the instant AC line voltage.

INTRODUCTION:

Without PFC, most SMPS simply rectify the AC voltage to charge a relatively large capacitor. This results in huge spikes drawn from the line which generates harmonics and degrades the power factor to 0.5 – 0.7.

With the IPS101, the power factor exceeds 0.95 and the harmonic distortion could be less than 5%. The IPS101 is also a very efficient pre-regulator that charges a storage capacitor at an adjustable regulated DC voltage. This feature can be used to build very high-efficiency and low-cost isolated SMPS featuring single or multiple outputs in the range of 50-500W.

OPERATING DESCRIPTION:**3-input current multiplier:**

The heart of the IPS101 PFC controller is a 3-input current-mode multiplier. This multiplier is key in monitoring a constant loop gain that is the only way to ensure a good stability and response over a broad range of input AC voltages and output loads.

The first multiplier input is fed by I_{AC} , a current proportional to the instant AC line voltage. This information is used to force the current drawn from the AC line to be proportional to the instant line voltage thus resulting in a power factor close to unity. The SMPS then behaves like a resistive load with an impedance that varies according to the RMS line voltage and the load thanks to the other action of the two multiplier inputs.

As shown in Fig. 1, a resistor (R1) connected between V_{AC} (pin 8) and the rectified AC line voltage, performs the V to I conversion that generates I_{AC} . The value of R1 is usually 1 M Ω .

The second multiplier input is fed by I_{RMS} , a current proportional to the AC line RMS value. This current is derived from I_{AC} by a dedicated RMS converter using only a non-critical external capacitor (C1).

The value of C1 is usually 1 μ F for 50 / 60Hz operations. A much lower value would result in a more harmonic distortion. The purpose of feeding the I_{RMS} is to reduce the loop gain at high voltages. It would otherwise become excessive and create stability problems.

The third multiplier input is fed by a current proportional to the error amplifier output voltage. The purpose is to smoothly change the RMS value of the sinusoidal current drawn from the AC line, to match the power demand and maintain a good regulation of the output voltage.

Voltage error amplifier:

The IPS101 includes a voltage error amplifier with a non-inverting input connected to an internally trimmed 2.06V reference. Its inverting input is available on pin 2. Its output is connected to pin 3 and is also internally connected to the V-to-I converter feeding the multiplier as discussed before. As indicated in the typical application schematic of figure 1, pin 2 and pin 3 are used for the following purposes:

(a) voltage divider R3, R4 used to set the value of the regulated DC output voltage:

$$DC\ out = 2.06 \times (R3 + R4) / R4 \text{ (see Fig. 1)}$$

(b) the loop feedback compensation network R2, C2, C6 (see Fig. 1) provides a suitable network for most applications. More complicated schemes are possible for demanding applications where transient response is paramount.

MOSFET current control:

The IPS101 is equivalent to a non-isolated flyback (boost) converter that operates from raw rectified AC. It uses a high-Q inductor operating in continuous mode to generate a regulated DC output that always slightly exceeds the peak value of the AC input voltage.

The maximum current in the inductor is set by the output of the multiplier and will increase with the output power demand. The minimum current in the inductor is internally set to 50% of the maximum current, which constitutes a good trade-off between energy transfer and switching losses / EMI signature at MOSFET turn-on.

When the V_{cc} is established, the control logic turns the MOSFET on. The current in the inductor (and also in the MOSFET) is sensed by R9 which value along with L1 defines the power handling capacity of the PFC.

When the current reaches the peak value set by the output voltage of the multiplier which never exceeds 1.2V, the MOSFET is switched off and the current in the inductor, still sensed by R9, decreases as the inductive energy is dumped into the storage capacitor. When the current decreases below 50% of the peak value, the control logic turns the MOSFET on again. The system is therefore self-oscillating and does not require any dedicated oscillator.

Please note that the frequency varies with the load and the line voltage, but against common belief:

- its variation usually stays in a 2:1 range,
- its jitter is favorable to the EMI signature,
- it decreases when the load increases which is excellent for the efficiency of the PFC.

MOSFET driver:

The MOSFET driver has been sized to be capable of driving power MOSFETs featuring a total gate charge up to 80nC.

Due to the continuous mode of operations of the inductor, the MOSFET must be driven with a reasonably (but not excessively) low impedance, to minimize switching losses at both turn-on and turn-off without generating too excessive EMI.

In term of Ron, the driver's output devices are as follow:

- P-channel Ron: 30 Ω typical
- N-channel Ron: 20 Ω typical

A series resistor R7 on pin7 should be added to further reduce EMI and minimize the noise injection which could result from Miller-capacitance kick-back during transient conditions.

Examples of suitable MOSFETs:

- **IXYS PolarHT™ and Polar HV™** MOSFET series: IXTY1R4N60P, IXTY2N60P, IXTY3N60P
- **Fairchild** MOSFET series: FQPF1N60, FQPF 2N60, FQPF 3N60.
- **Infineon COOLMOS™** series: SPD01N60S5, SPD02N60S5, SPD03N60S5.
- **Motorola** MOSFET series: MTP1N60, MTP2N60, MTP3N60.
- **SGS-Thomson** MOSFET series: STD1NB60, STD2NB60, STD3NB60.
- Etc...

Notes:

- Due to the rapid evolution of MOSFET technologies, please check for current models when designing a new SMPS.
 - **PolarHT™ and Polar HV™** are trademarks of IXYS corporation
- COOLMOS™** is a trademark of Infineon.

Thermal shutdown:

An internal temperature sensing protection circuit disables the MOSFET gate drive when the temperature exceeds a typical value of 150°C. This circuit has sufficient hysteresis to prevent relaxation. Normal operations therefore only resume when the junction temperature has dropped below approximately 120°C.

Shunt bandgap regulator:

The IPS101 internal trimmed bandgap shunt regulator behaves like a 10V zener but also provides the 2.06V reference for the voltage error amplifier, and the various internal bias current and voltages required by the different blocks.

During start-up, the current consumption in the regulator is very low, typically 100µA, allowing many possible schemes to power the IPS101. Once the “zener” value is reached, the MOSFET gate drive is enabled and normal operation starts. When enabled, the typical chip consumption is 660 µA plus the current necessary to drive the MOSFET which depends on the MOSFET's total gate charge and the frequency of operation (linked to L1 inductance value).

The VCC voltage is allowed to drop below the “zener” value during normal operations but the circuit will reset itself and re-enter start-up mode should the VCC drop below approximately 8 volts.

The shunt regulator is sized to handle up to 50mA, which is especially useful to power the IPS101 with few components only. Be careful however not to exceed the package rated power dissipation (see table p7).

How to power the IPS101:

There are several ways of supplying power to the IPS101 which depends on whether the PFC is used as a stand-alone block or is followed by a DC/DC converter or other blocks using additional ICs which must be energized as well.

Stand-alone applications

Simple RC network:

The simplest technique well suited for 120V AC (domestic US and Japan) uses an RC network connected between DC out and GND. R5 should be sized to deliver enough I_{cc} current for normal operation without wasting power.

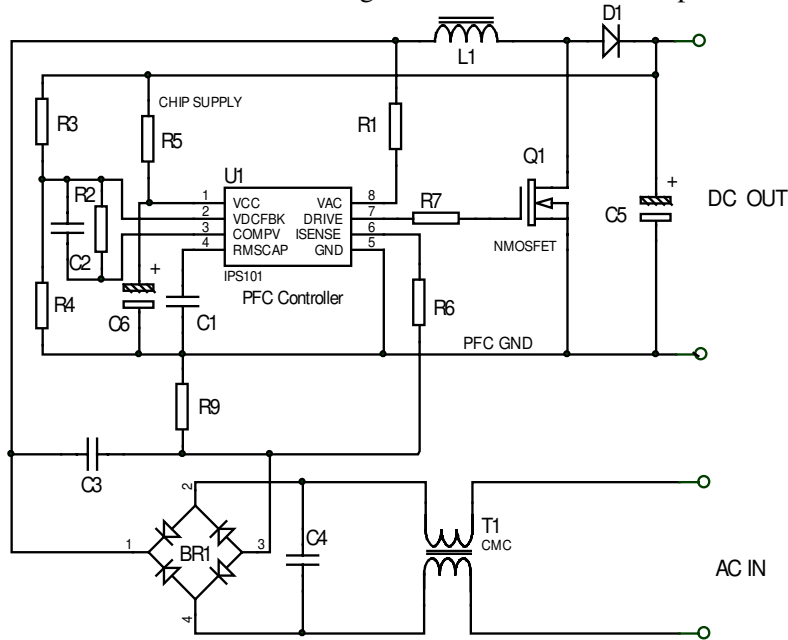

Figure 4

Auxilliary winding:

The most efficient technique suitable for international applications (85V- 265V AC) uses an auxilliary winding on the switching inductor TX1. The turn-ratio between the principal winding and this auxilliary one is usually between 5 and 15. The wire size should be suitable for 20mA RMS which is quite small.

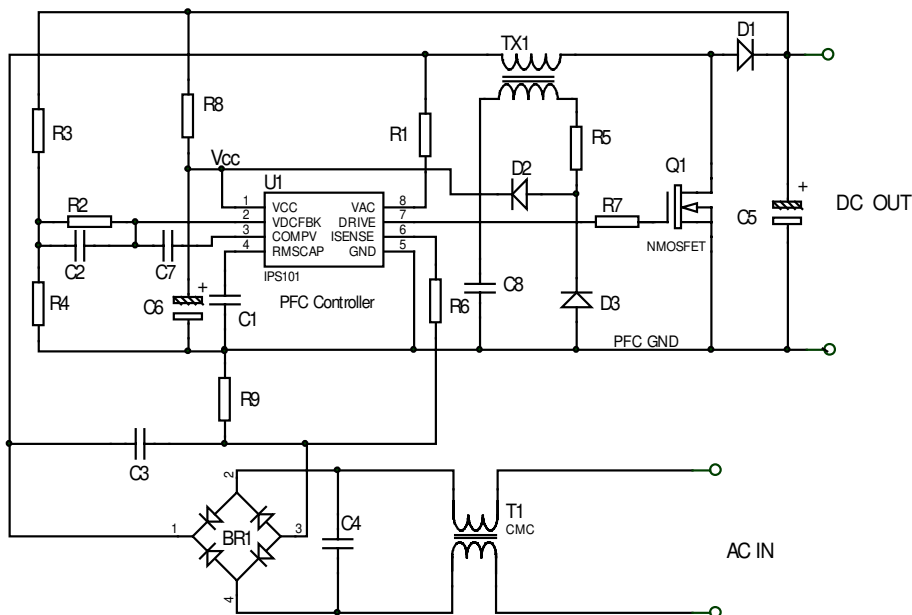
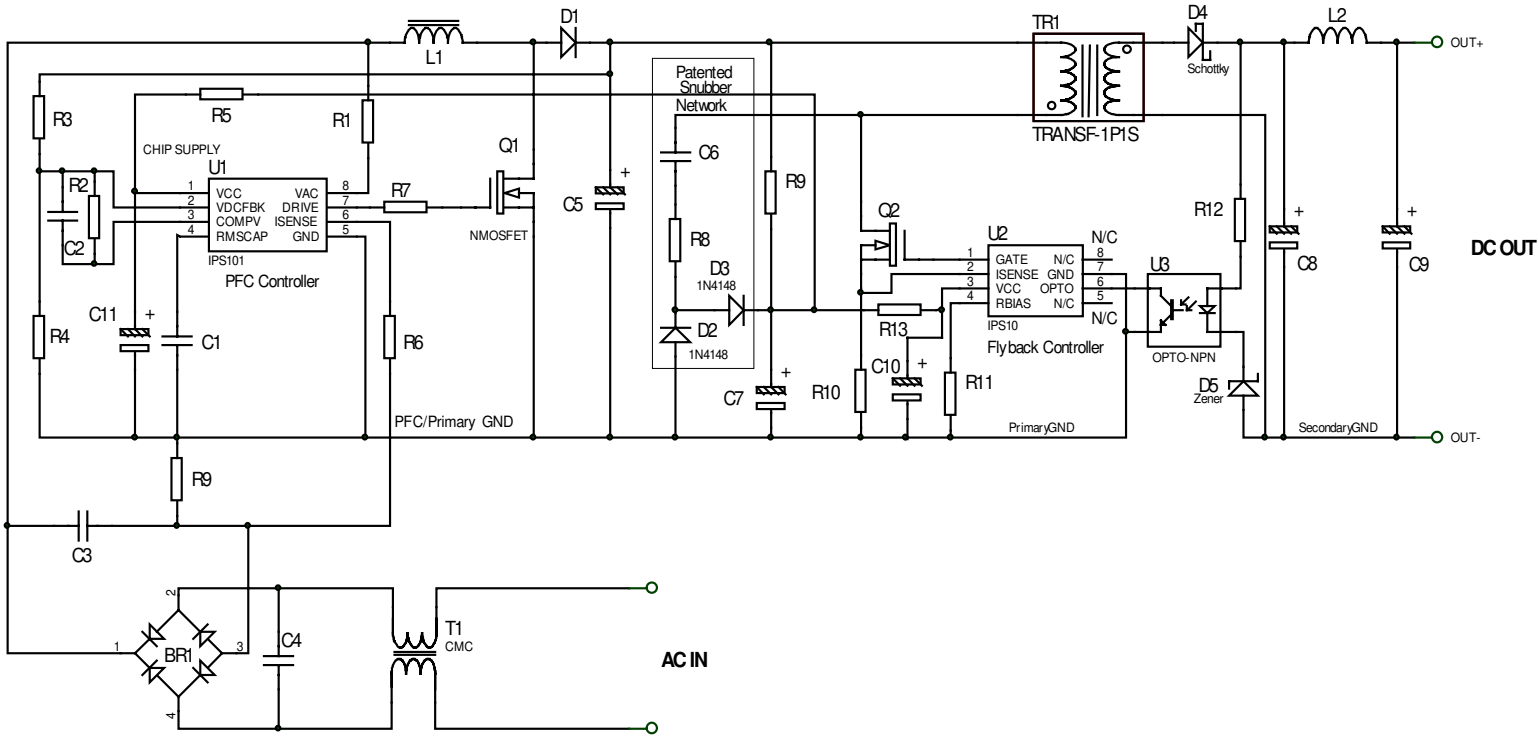

Figure 5

Applications with DC/DC converter:

The auxilliary winding on L1 can be saved and the VCC supply for the the IPS101 is then provided by the DC/DC converter circuitry. The current provided by AAI patented snubber and R9/C7 networks is divided and derived into R13/C10 and R5/C11 to feed flyback and feedback controllers respectively.



ELECTRICAL CHARACTERISTICS

ABSOLUTE MAXIMUM RATING		
Characteristics	Value	UNITS
Shunt regulator max I _{CC} non-repetitive current (pin 1) - see fig 7-	60	mA
Peak drive output current (pin7)	Source=100, Sink=200	mA
Isense input voltage (pin 6)	0 / - 10	V
VAC maximum input current (pin8)	700	μA
Junction to case thermal resistance R _{θJ-C}	PDIL = 42, SOIC = 45	°C / W
Junction to PCB thermal resistance R _{θJ-A}	PDIL = 125, SOIC =155	
Power dissipation for T _A <= 70°C	PDIL = 640, SOIC = 500	mW
Operating junction temperature	- 40 to 150	°C
Storage temperature range	- 55 to 150	
Lead temperature (3 mm from case for 5 sec.)	260	

PARAMETER	TEST CONDITIONS	PARAMETERS			UNITS
		MIN.	TYP.	MAX.	
@ 25°C unless specified					
Supply, bias & circuit protection					
Shunt regulator voltage (V_{CC})	$I_{CC} = 10 \text{ mA}$	9.7	10.0	10.3	V
Shunt regulator dynamic resistance	1 to 30 mA	2	4	6	Ω
Shunt regulator peak repetitive current (I_{CC})		-	-	50	mA
Start-up current (I_{CC})		-	100	150	μA
Under voltage lock-out (V_{CC})		$V_{CC} - 2.1$	$V_{CC} - 1.8$	$V_{CC} - 1.4$	V
Min I_{CC} to ensure continuous operation	4A, 600V, 20 nC MOSFET , L= 7 mH	-	3	-	mA
Thermal shutdown trip temperature		-	150	-	$^{\circ}\text{C}$
Multiplier					
Maximum operating voltage across ISENSE resistor (R9)	See note2	-1.3	-1.2	-1.1	V
COMP voltage range		0	-	3	V
VAC input current operating range	$I_{CC} = 1 \text{ to } 10 \text{ mA}$ Temp = 0 to 70°C	20	-	600	μA
RMS capacitor (pin4)		-	1	-	μF
Error amplifier					
Reference voltage	$I_{CC}=10\text{mA}$	2.01	2.06	2.10	V
Open loop gain		-	85	-	dB
3 dB response		-	200	-	Hz
Phase margin	Unity gain	65	-	-	Degrees
Output impedance		-	30	-	K Ω
P & N Outputs to MOSFET gate					
P gate driver saturation	10 mA (source)	-	0.3	0.5	V
N gate driver saturation	10 mA (sink)	-	0.2	0.35	V
Gate pull-down resistor	(internal)	30	45	65	K Ω
PDRIVE Rise time (10% to 90%)	390 pF load	-	100	200	ns
NDRIVE Fall time (10% to 90%)	390 pF load	-	50	100	ns
Max recommended total external MOSFET charge		-	-	50	nC

Note1: Electrical parameters, although guaranteed, are not all 100% tested in production.

Note2: To avoid damage to pin 6 by the in-rush current, size R6 to limit the input current into the IC to 30mA. 1Kohm to 33Kohm are suitable values for most applications.

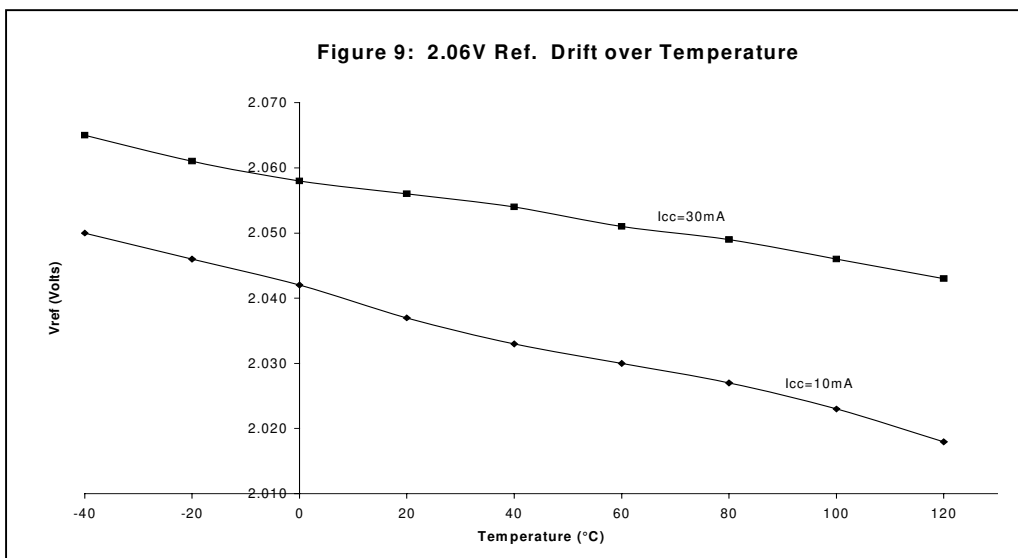
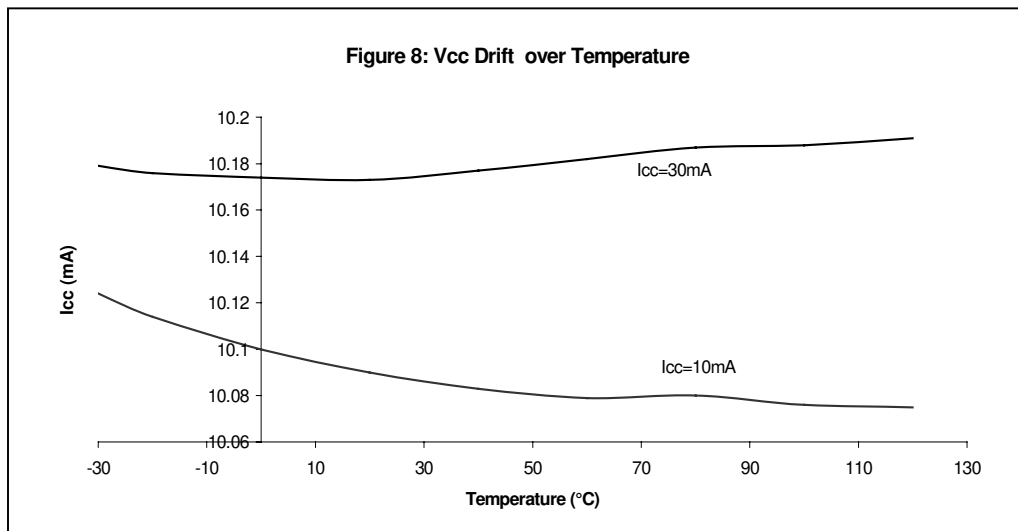
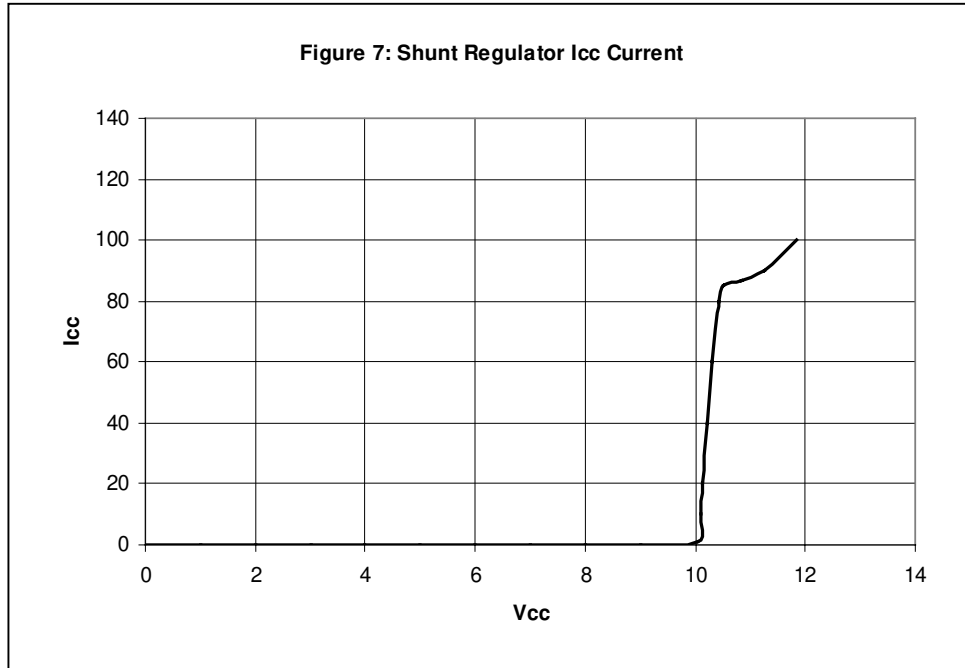

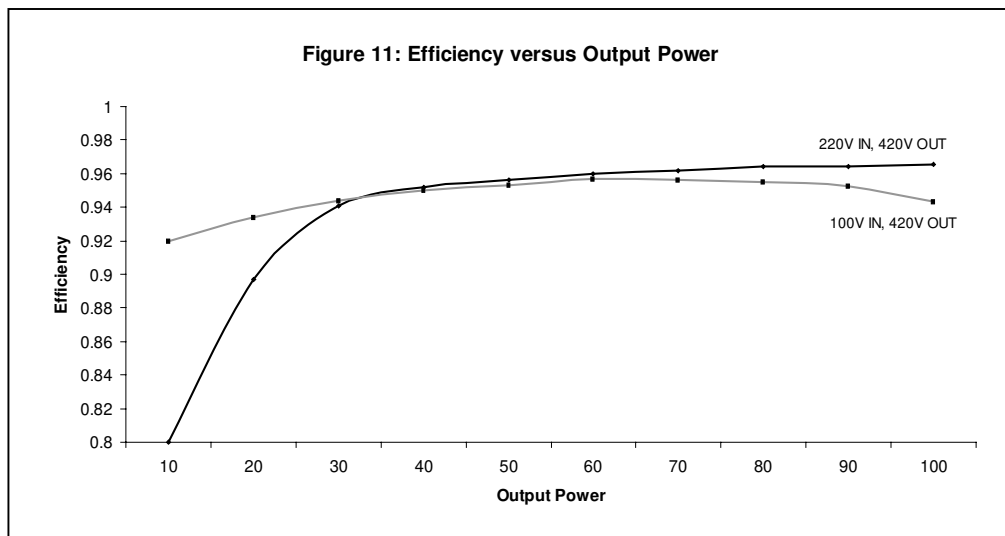
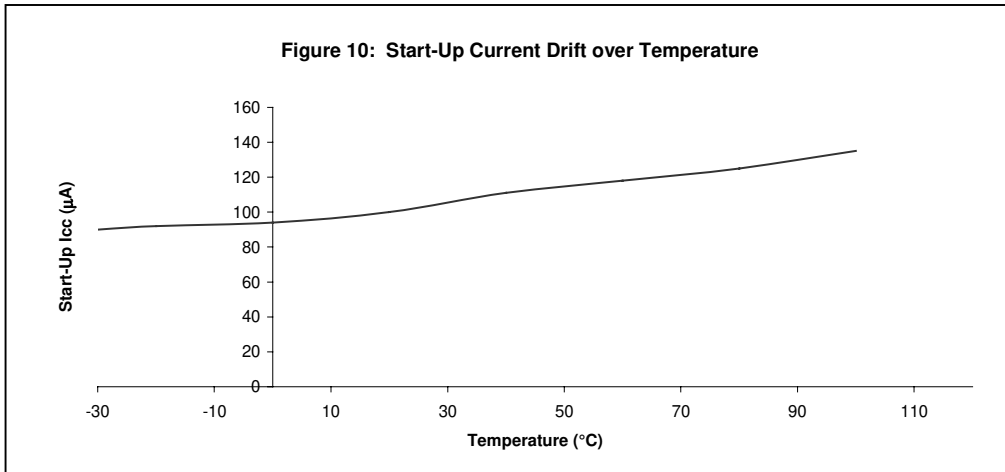

EXAMPLE OF POWER FACTOR CORRECTION: Universal Input, 400V DC, 100W output

Figure 12

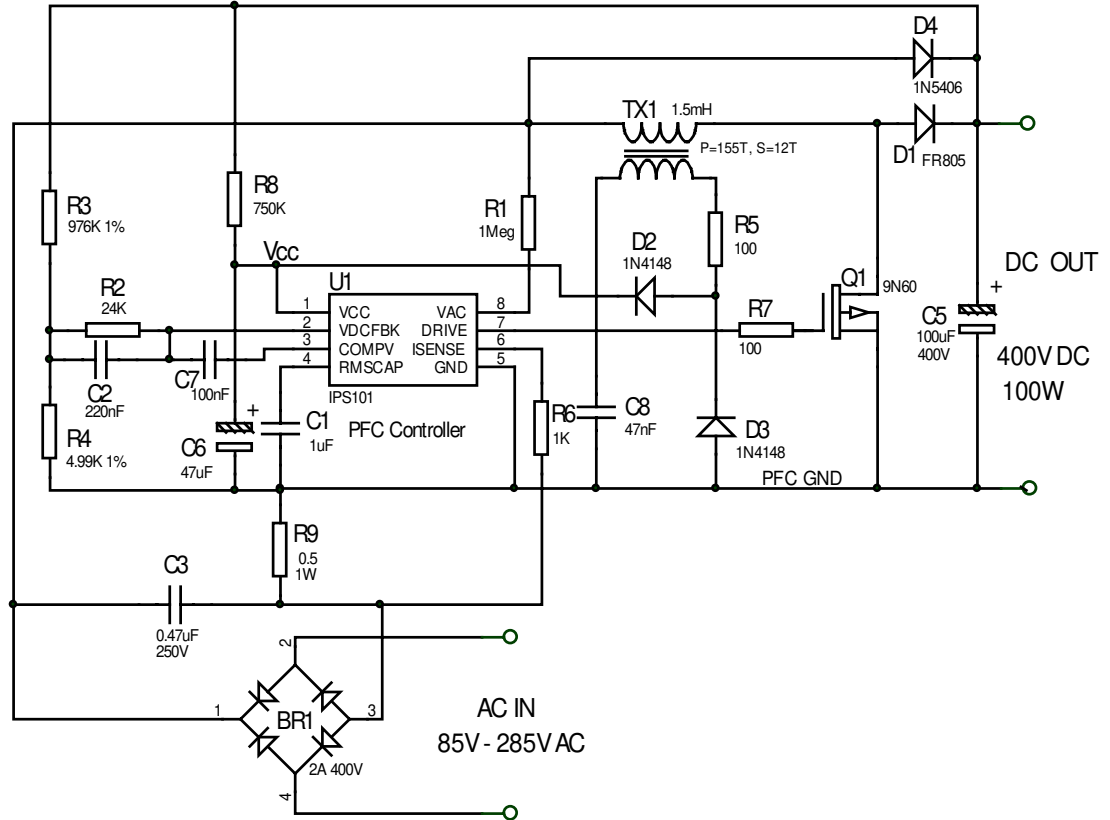

Note: 1mH to 10mH inductors (TX1) could be used depending on conditions and targeted characteristics.

Line current waveforms: measured on IPS-DK101 demo-kit

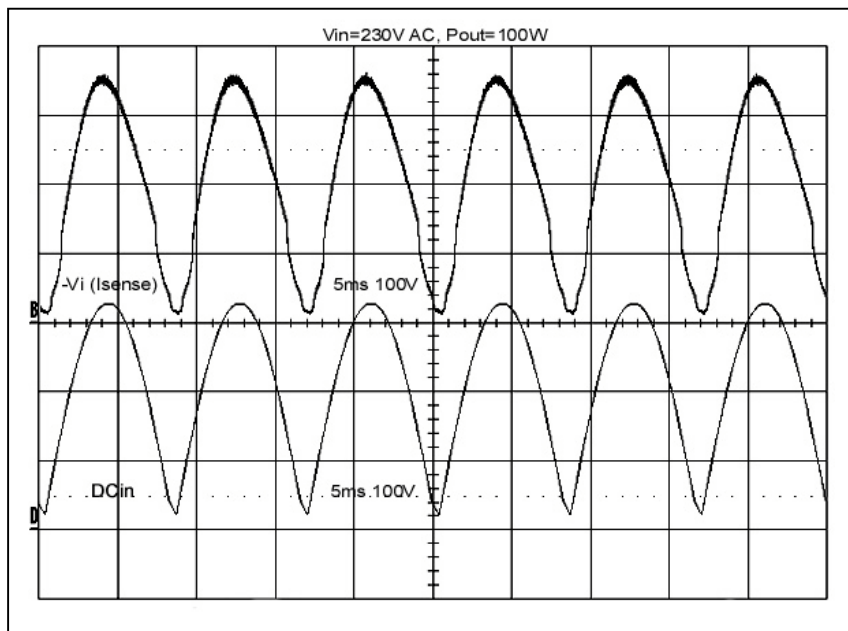

Vin= 230V, Pout=100W

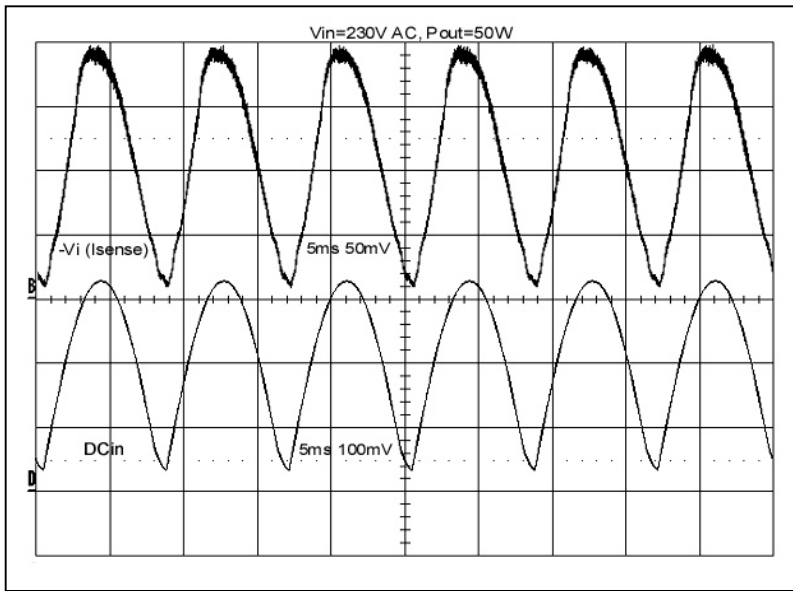

Vin= 230V, Pout=50W

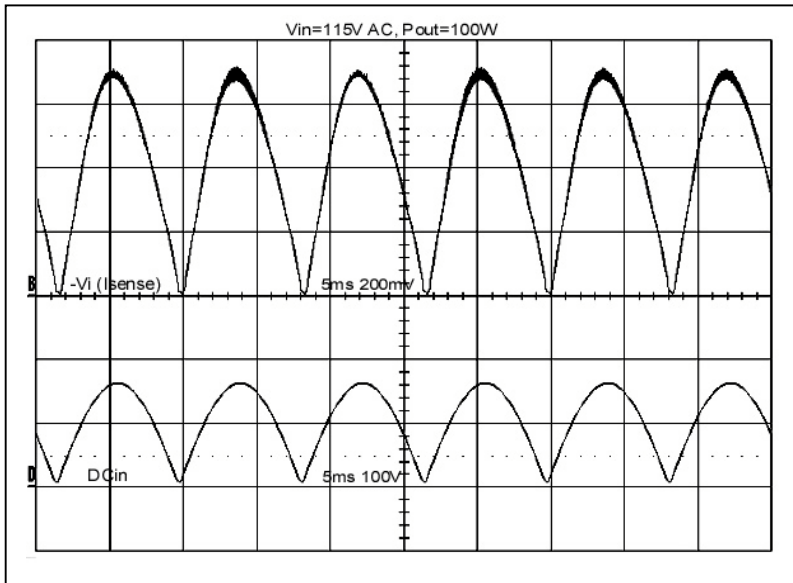

Vin= 110V, Pout=100W

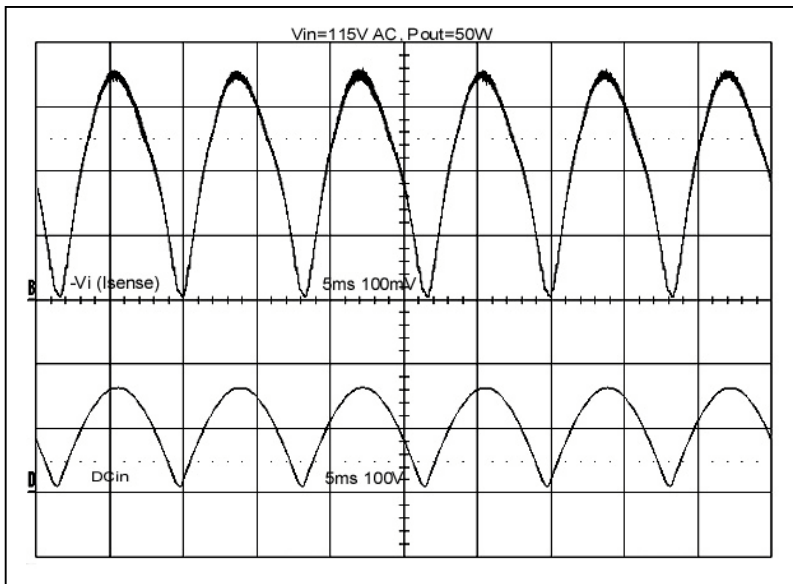

Vin= 110V.Pout=50W

PACKAGE DIMENSIONS

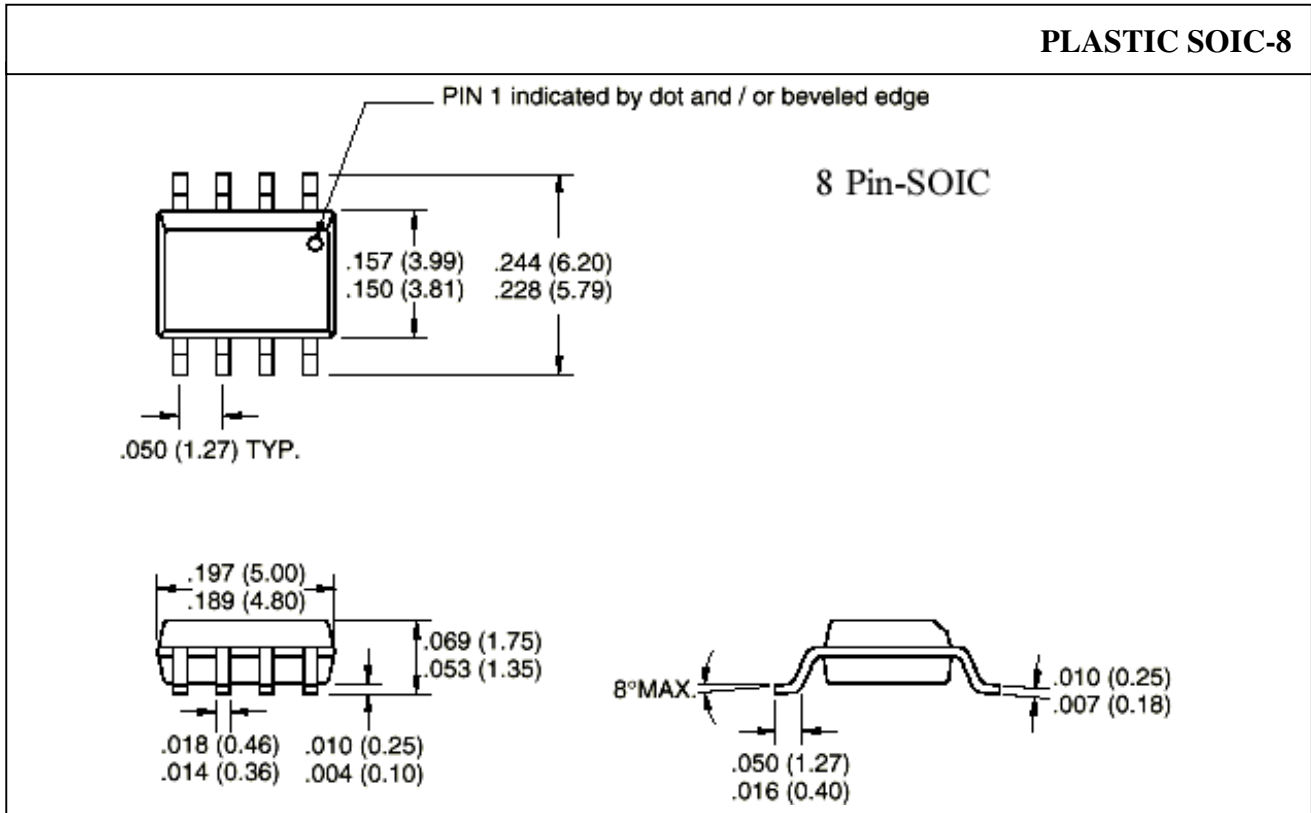
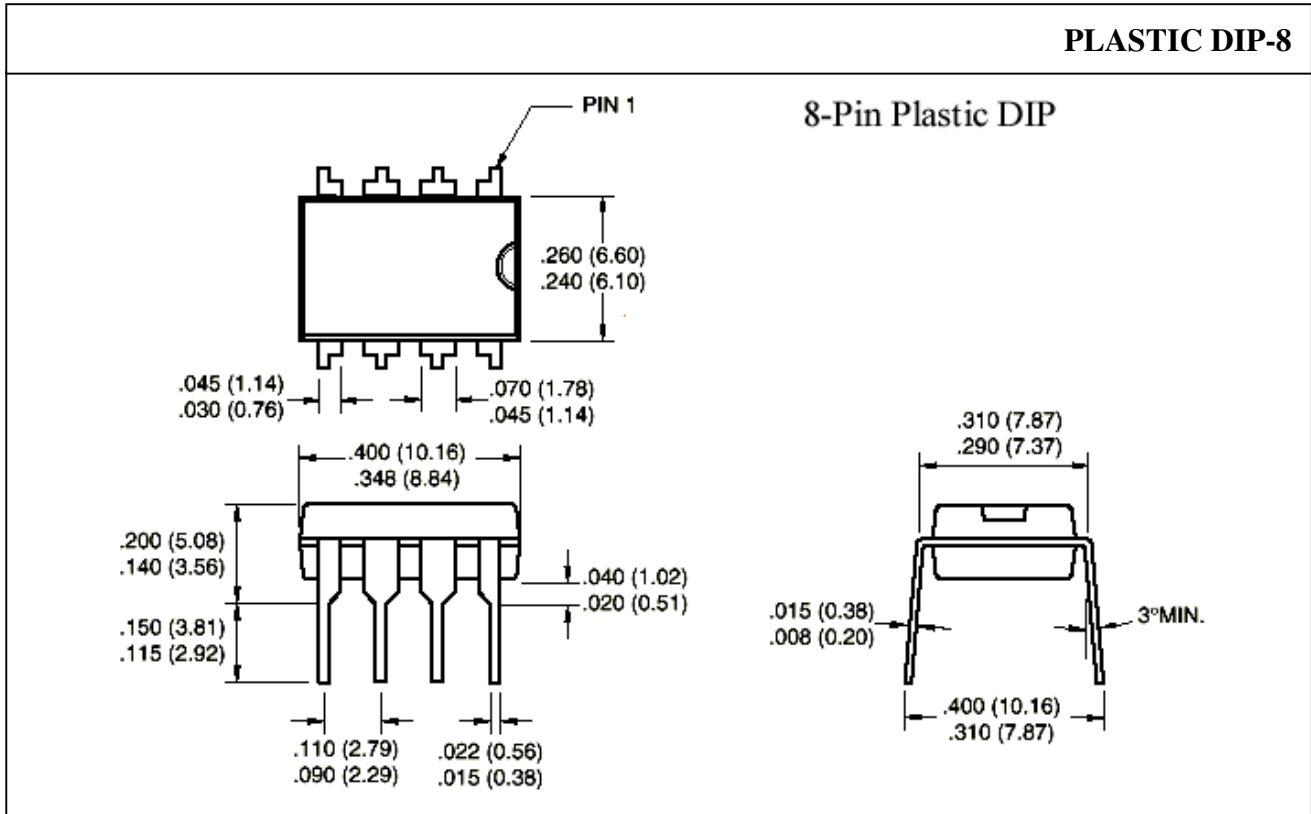

ORDERING INFORMATION

Part-Number

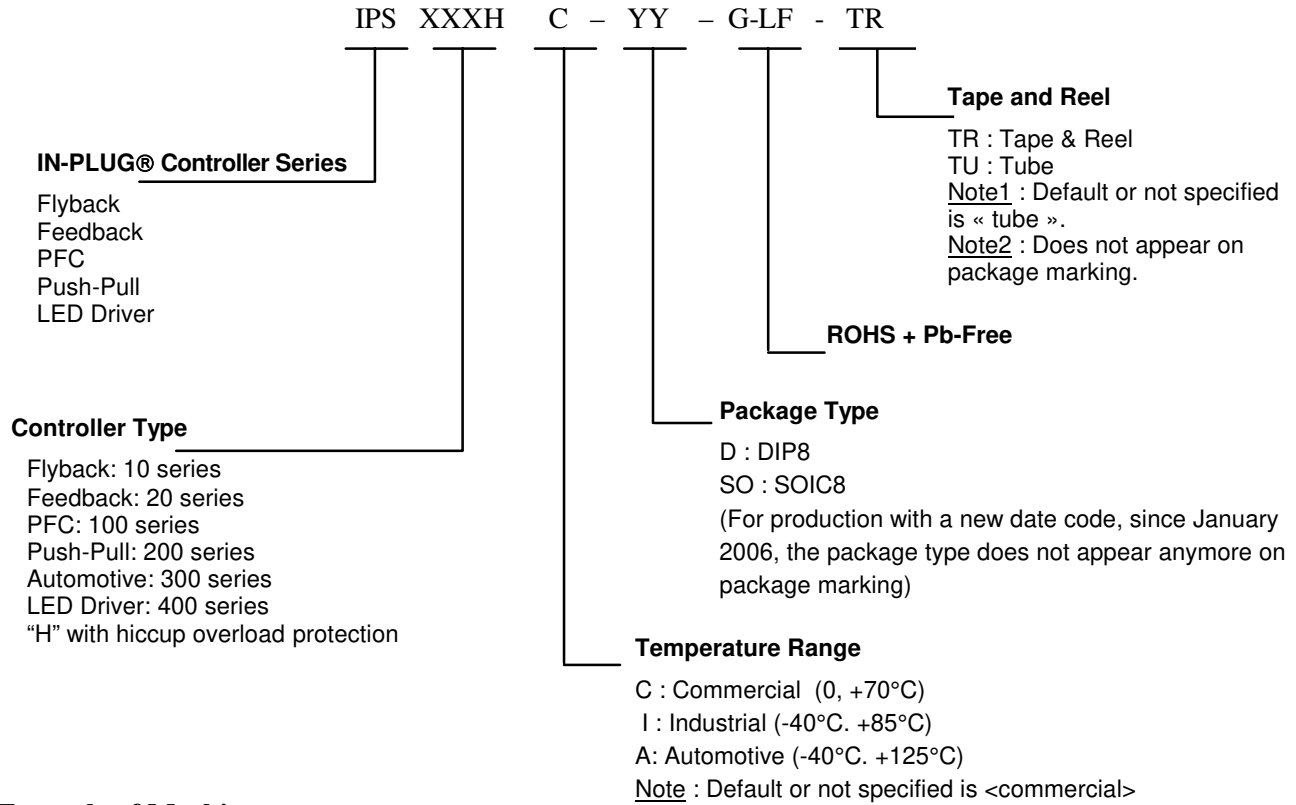

Example of Marking



Non-Green Package

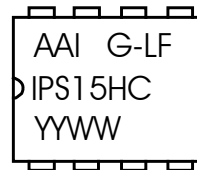

Green ROHS + Pb-Free Package

(Note : For production with a new date code, since January 2006, the package type does not appear anymore on package marking)

This ordering information is for commercial and industrial standard IN-PLUG® controllers ONLY. For custom controllers or for military temperature range, call AAI's sales representative.

The following is a brief overview of certain terms and conditions of sale of product. For a full and complete copy of all the General Terms and Conditions of Sale, visit our webpage <http://www.asicadvantage.com/terms.htm>.

LIMITED WARRANTY

The product is warranted that it will conform to the applicable specifications and be free of defects for one year. Buyer is responsible for selection of, use of and results obtained from use of the product. Buyer indemnifies and holds ASIC Advantage, Inc. harmless for claims arising out of the application of ASIC Advantage, Inc.'s products to Buyer's designs. Applications described herein or in any catalogs, advertisements or other documents are for illustrative purposes only.

CRITICAL APPLICATIONS

Products are not authorized for use in critical applications including aerospace and life support applications. Use of products in these applications is fully at the risk of the Buyer. Critical applications include any system or device whose failure to perform can result in significant injury to the user.

LETHAL VOLTAGES

Lethal voltages could be present in the applications. Please comply with all applicable safety regulations.

INTELLECTUAL PROPERTY RIGHTS AND PROPRIETARY DATA

ASIC Advantage, Inc. retains all intellectual property rights in the products. Sale of products does not confer on Buyer any license to the intellectual property. ASIC Advantage, Inc. reserves the right to make changes without notice to the products at any time. Buyer agrees not to use or disclose ASIC Advantage Inc.'s proprietary information without written consent.

TRADEMARKS AND PATENTS

- IN-PLUG® is a registered trademark of ASIC Advantage, Inc.
- AAI's modified snubber network is patented under the US Patent # 6,233,165. IN-PLUG® Customers are granted a royalty-free licence for its utilization, provision the parts are purchased factory direct or from an authorized agent.

PROTECTION FOR CUSTOM IN-PLUG® SOLUTIONS

When AAI accepts to design and manufacture IN-PLUG® products to Buyer's designs or specifications, buyer has certain obligations to provide defense in a suit or proceeding claiming infringement of a patent, copyright or trademark or for misappropriation of use of any trade secrets or for unfair competition.

COMPLIANCE WITH LAWS

Buyer agrees that at all times it will comply with all applicable federal, state, municipal, and local laws, orders and regulations. Buyer agrees to comply with all applicable restrictions on exports and re-exports including obtaining any required U.S. Government license, authorization, or approval. Buyer shall pay any duties, levies, taxes, brokerage fees, or customs fees imposed on the products.

TITLE AND DELIVERY

All shipments of goods shall be delivered ExWorks, Sunnyvale, CA, U.S.A. Title in the goods shall not pass to Buyer until ASIC Advantage, Inc. has received in full all amounts owed by Buyer.

LATEST DATASHEET UPDATES

For the latest datasheet updates, visit our web page: <http://www.in-plug.com/datasheets.htm>.

WORLDWIDE REPRESENTATIVES

To access AAI's list of worldwide representatives, visit our web page <http://www.in-plug.com/representatives.htm>

COPYRIGHTS

Copyrights and all other proprietary rights in the Content rests with ASIC Advantage Inc. (AAI) or its licensors. All rights in the Content not expressly granted herein are reserved. Except as otherwise provided, the Content published on this document may be reproduced or distributed in unmodified form for personal non-commercial use only. Any other use of the Content, including without limitation distribution, reproduction, modification, display or transmission without the prior written consent of AAI is strictly prohibited. All copyright and other proprietary notices shall be retained on all reproductions.

ASIC Advantage INC.

1290-B Reamwood Ave, Sunnyvale California 94089, USA
Tel: (1) 408-541-8686 Fax: (1) 408-541-8675
Websites: <http://www.in-plug.com> - <http://www.asicadvantage.com>