

# CODE 41 - HEAT SHRINK BOOT BACKSHELL

202M216-19C

SERIES \_\_\_\_\_  
 ORDER NUMBER (TABLE 1) \_\_\_\_\_  
 MATERIAL \_\_\_\_\_  
 REFER TO CH00-0250-004  
 FINISH \_\_\_\_\_  
 REFER TO CH00-0250-004  
 MODIFICATION CODE \_\_\_\_\_  
 REFER TO CH00-0250-004 (2)

## NOTES:



1. THIS PRODUCT IS DESIGNED TO TERMINATE A HEAT SHRINKABLE LIPPED BOOT TO A CONNECTOR.

(2) FOR ADDITIONAL DIMENSIONS, ORDERING INFORMATION AND MODIFICATIONS, SEE CH00-0250-004.

3. ADAPTOR TO BE PERMANENTLY MARKED/BAGGED AND LABELLED WITH CODE IDENTIFICATION NUMBER AND PART NUMBER. (e.g. 06090-202M216-19B).

(4) BACKSHELL MATES TO MIL-C-38999 SERIES I & II, CLASS E & T, MS27466, MS27467, MS27468, MS27472, MS27473, MS27474, MS27479, MS27480, MS27481, MS27484, MS27497, MS27653, MS27656 CONNECTORS.

If this document is printed it becomes uncontrolled. Check for the latest revision

DRAWN	K.WINCZURA	DATE	19/02/2015	 3RD ANGLE PROJECTION NOT TO SCALE	TITLE:	HEAT SHRINK BOOT BACKSHELL	 		
CHECKED		DATE	19/02/2015						
APPROVED	K.SHEPPARD	DATE	03/03/2015		UNLESS OTHERWISE SPECIFIED ALL DIMENSIONS IN MILLIMETRES GENERAL TOL LINEAR +/-0.25MM ANGULAR +/- 1°	ASSY USED ON:		MIL-DTL-38999 SERIES I & II (CODE 41)	
APPROVED	H.SMITH	DATE	01/09/2015						
REVISIONS									
LTR	DESCRIPTION	DATE	APPROVED						
N	REVISED PER ECN AD93016								
P	REVISED PER ECO-15-011999	01/09/2015	H.SMITH						
TE CAGE CODE: 06090 POLAMCO/TE CAGE CODE: U5792					TE CONNECTIVITY - POLAMCO LTD RESERVES THE RIGHT TO AMEND THIS DRAWING AND THE INFORMATION SET FORTH HEREON AT ANY TIME. USERS SHOULD INDEPENDENTLY EVALUATE THE SUITABILITY OF THE PRODUCT FOR THEIR APPLICATION.		DRAWING NO: 202M2XX	DRAWING REV: P	SHT 1

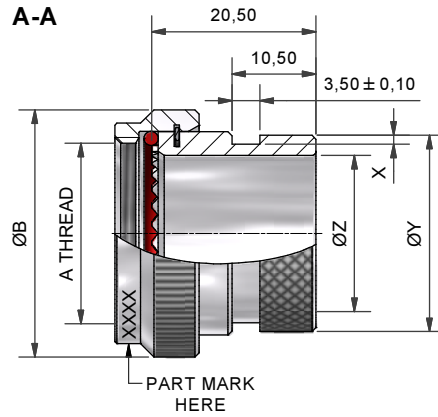
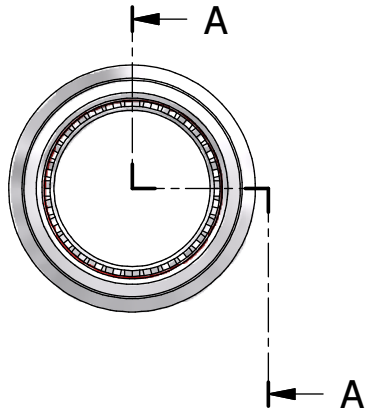





TABLE 1

ORDER NUMBER	SHELL SIZE SER 1 / SER 2	A THREAD	ØB MAX	X +0,20/-0,00	ØZ MIN	ØY +0,00/-0,50
08	09 / 08	7/16-28UNEF	18,3	1,12	6,60	13,50
10	11 / 10	9/16-24UNEF	21,5	1,12	10,00	15,40
12	13 / 12	11/16-24UNEF	24,5	1,12	12,90	19,70
14	15 / 14	13/16-20UNEF	27,8	1,12	16,10	21,30
16	17 / 16	15/16-20UNEF	30,8	1,12	19,30	24,50
18	19 / 18	1 1/16-18UNEF	34,1	1,12	21,70	26,50
20	21 / 20	1 3/16-18UNEF	37,3	1,75	24,80	31,00
22	23 / 22	1 5/16-18UNEF	40,5	1,75	28,20	34,40
24	25 / 24	1 7/16-18UNEF	43,7	1,75	31,30	36,60

DRAINHOLE OPTION



If this document is printed it becomes uncontrolled. Check for the latest revision

DRAWN	K.WINCZURA	DATE	19/02/2015	 3RD ANGLE PROJECTION NOT TO SCALE	<b>TITLE:</b>  <b>HEAT SHRINK BOOT BACKSHELL</b>	 <b>Polamco</b> 	
CHECKED		19/02/2015					
APPROVED	K.SHEPPARD	03/03/2015	<small>UNLESS OTHERWISE SPECIFIED ALL DIMENSIONS IN MILLIMETRES GENERAL TOL LINEAR +/-0,25MM ANGULAR +/- 1°</small>				
APPROVED	H.SMITH	01/09/2015					
<b>REVISIONS</b>					<b>ASSY USED ON:</b>  <b>MIL-DTL-38999 SERIES I &amp; II (CODE 41)</b>	<small>TE CONNECTIVITY - POLAMCO LTD RESERVES THE RIGHT TO AMEND THIS DRAWING AND THE INFORMATION SET FORTH HEREON AT ANY TIME. USERS SHOULD INDEPENDENTLY EVALUATE THE SUITABILITY OF THE PRODUCT FOR THEIR APPLICATION.</small>	
LTR	DESCRIPTION	DATE	APPROVED				
N	REVISED PER ECN AD93016						
P	REVISED PER ECO-15-011999	01/09/2015	H.SMITH				
TE CAGE CODE: 06090 POLAMCO/TE CAGE CODE: U5792					<b>DRAWING NO:</b> <b>202M2XX</b>	<b>DRAWING REV:</b> <b>P</b>	<b>SHT</b> <b>2</b>