

REVISIONS					
REV	DATE	DESCRIPTION	BY	CHK	APP'D
J3	21JUL2022	REVISED PER ECR-21-118222	JP	VS	

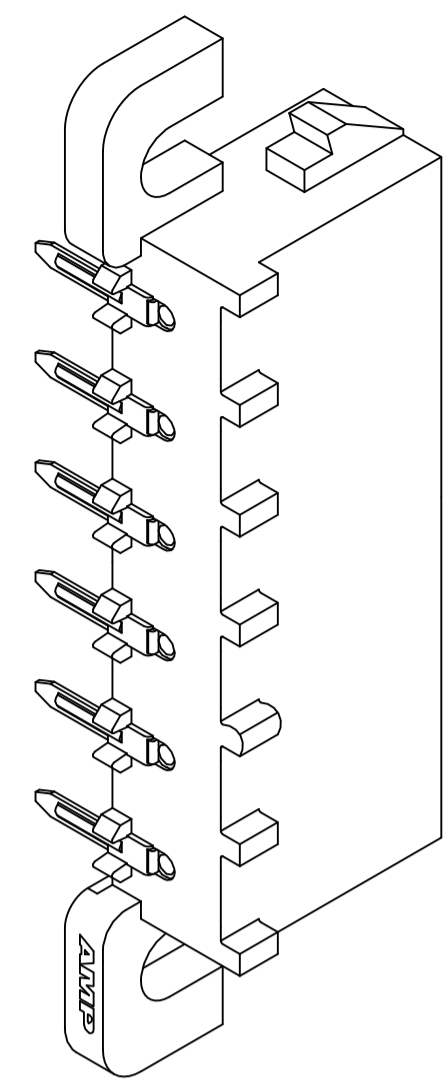

3-DIMENSIONAL MODEL NTS

- 1 PARTS COMPLY WITH AMP SOLDERABILITY SPECIFICATION 109-11-5.
- 2 CIRCUIT IDENTIFICATION CHARACTERS ARE ADJACENT TO THE INDICATED CAVITIES, BUT LOCATION AND ORIENTATION MAY DIFFER FROM PRINT.
- 3 CONTACT IS PLATED OVERALL WITH 0.00127 MIN NICKEL, THEN 0.00076 GOLD OVER CONTACT LENGTH INDICATED AND MATTE TIN LEAD FINISH ON SOLDER TAIL END.
- 4 OPTIONAL CONSTRUCTION MAY DELETE THIS RIB.
- 5 CONTACT IS PLATED OVERALL WITH 0.00127 MIN NICKEL, THEN 0.00076 GOLD OVER CONTACT LENGTH INDICATED AND MATTE TIN FINISH ON SOLDER TAIL END.
- 6 SUPERSEDED BY 640583-3
- 7 DIMENSIONS SHOWN REPRESENT PRODUCT IN DRY CONDITION. ADDITIONAL 2% GROWTH DUE TO END USE LOCATION MOISTURE ABSORPTION MAY OCCUR AND SHOULD BE ACCOUNTED FOR.

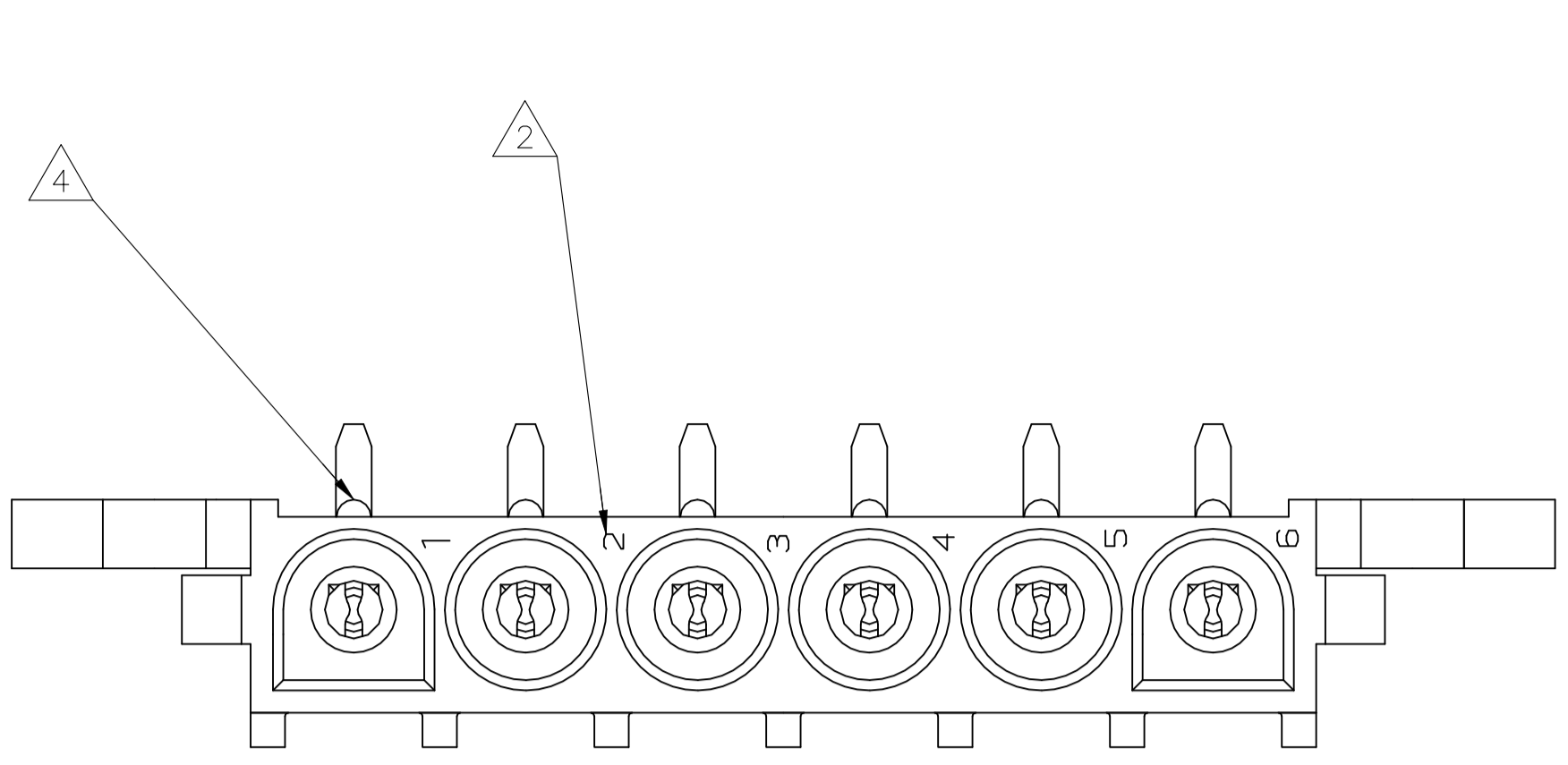
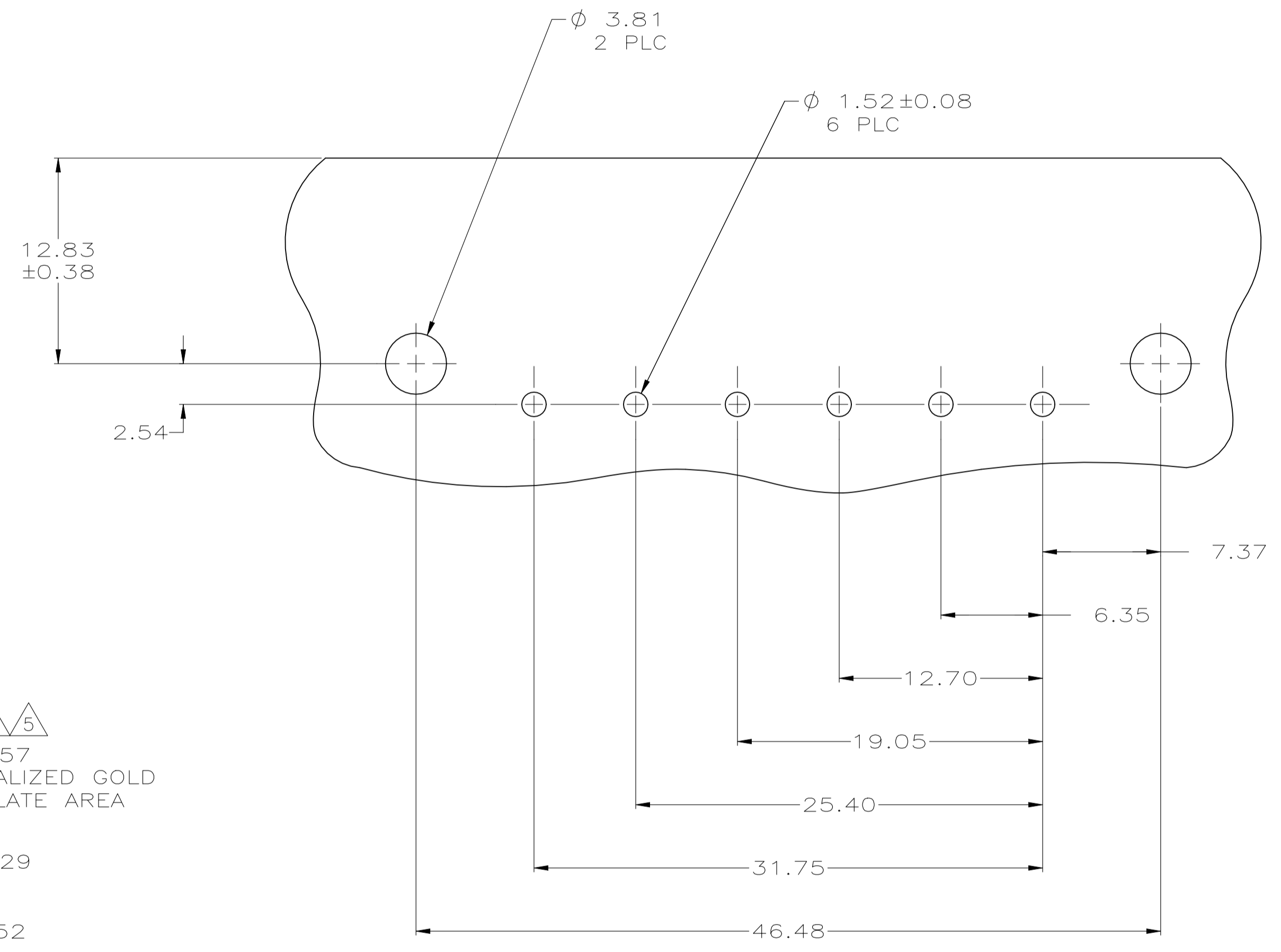
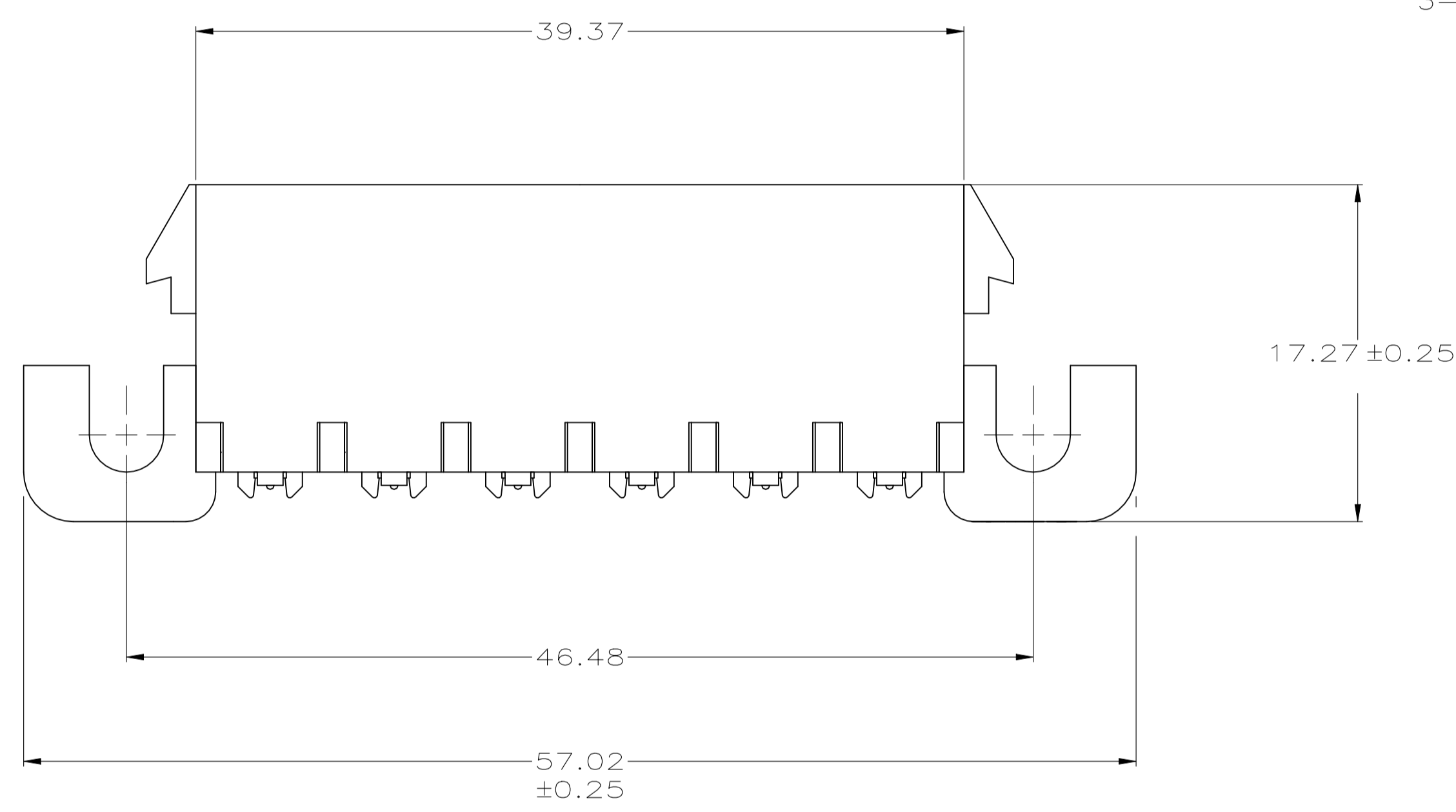

RECOMMENDED MOUNTING HOLE PATTERN FOR 1.57 THICK P.C. BOARD

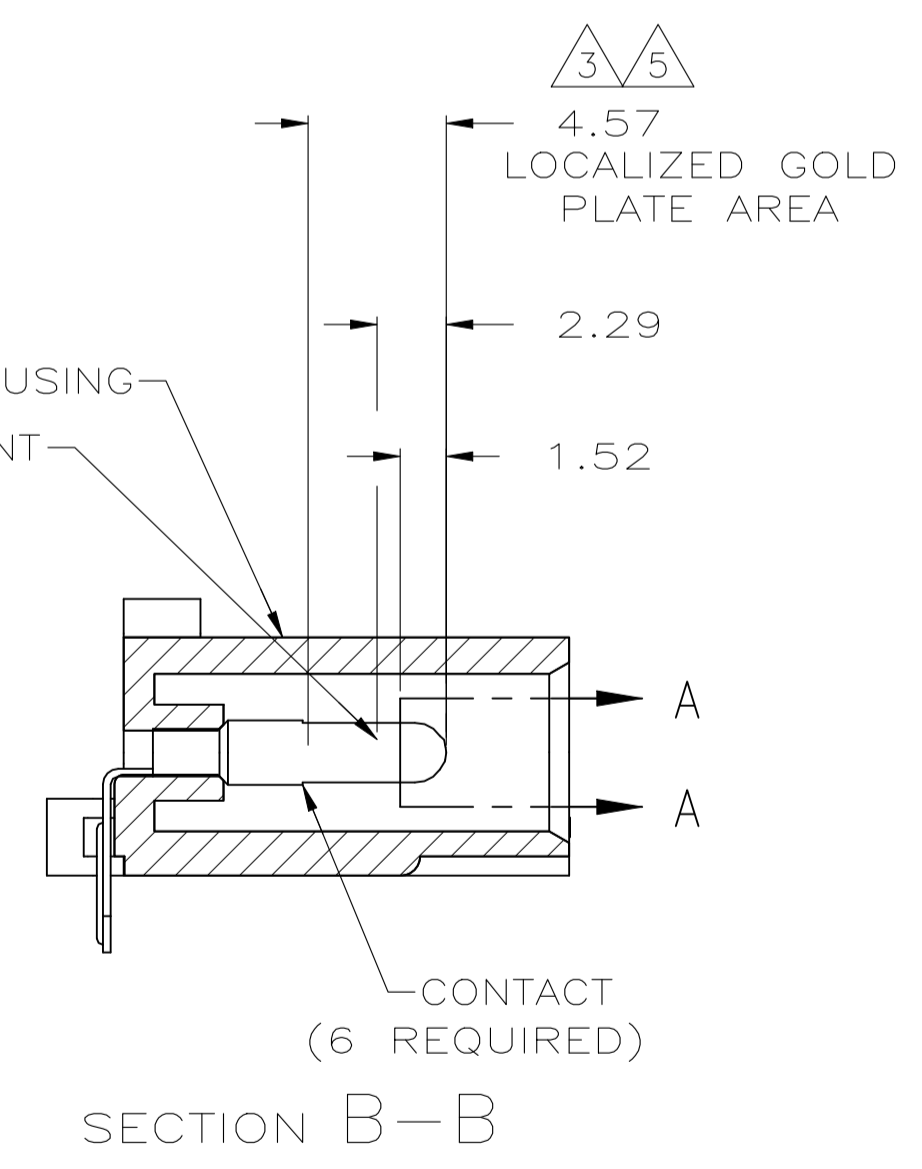
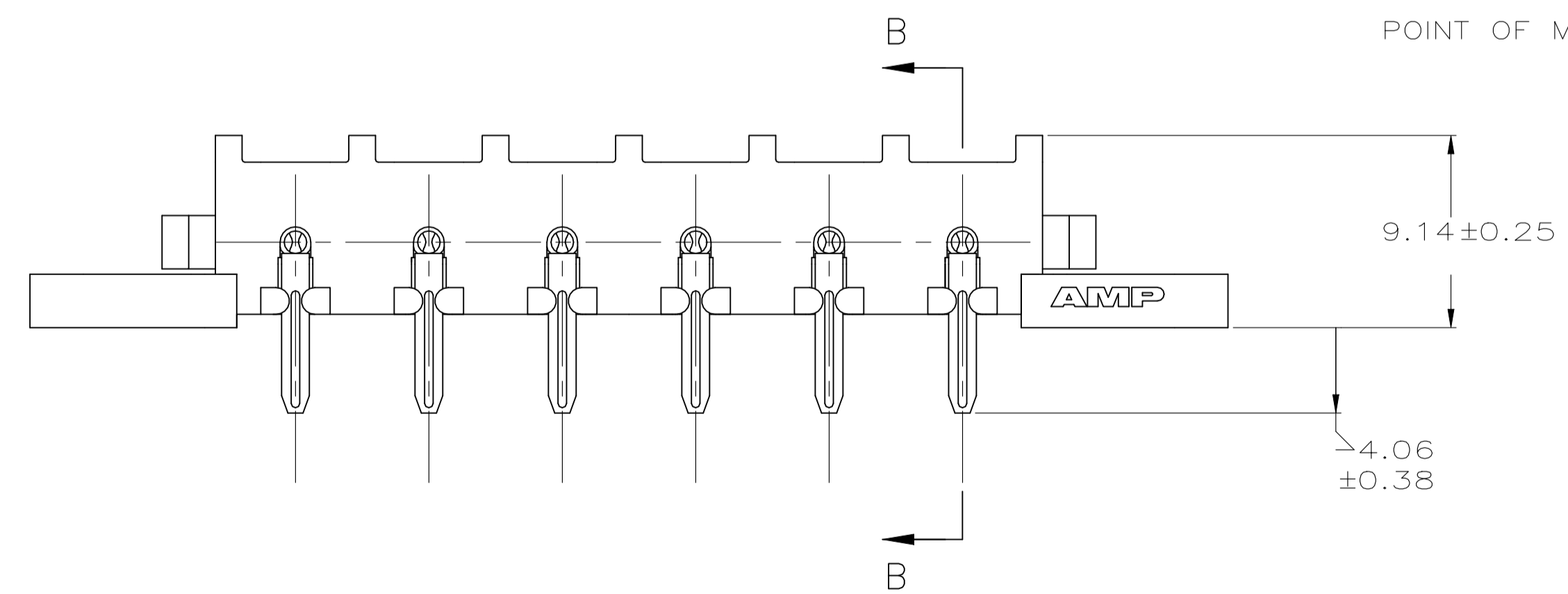

SECTION B-B

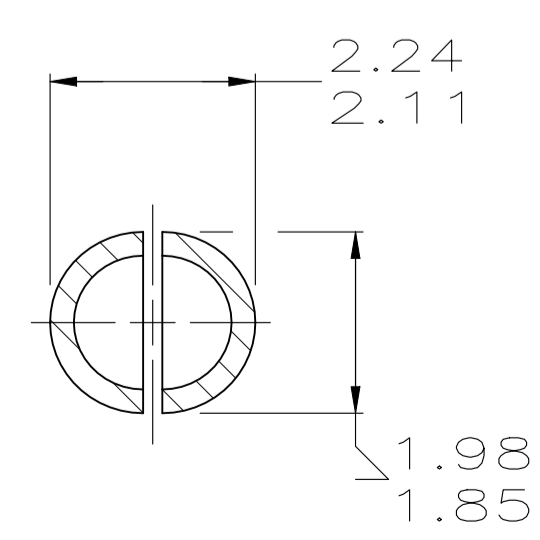

SECTION A-A SCALE 10:1

MM	IN	MM	IN	MM	IN
1.98	.078	9.14	.360	-	-
1.85	.073	7.37	.290	57.02	2.245
1.57	.062	6.35	.250	46.48	1.830
1.52	.060	4.57	.180	39.37	1.550
0.38	.015	4.06	.160	31.75	1.250
0.25	.010	3.81	.150	25.40	1.000
0.13	.005	2.54	.100	19.05	.750
0.08	.003	2.29	.090	17.27	.680
0.00127	0.000050	2.24	.088	12.83	.505
0.00076	0.000030	2.11	.083	12.70	.500

CONVERSION TABLE

PH BRZ GOLD <sup>5</sup>	NYLON, UL94V-0	640583-3
PH BRZ GOLD <sup>3</sup>	NYLON, UL94V-0	640583-2
PH BRZ TIN	NYLON, UL94V-0	640583-1
CONTACT	HOUSING	PART NO

THIS DRAWING IS A CONTROLLED DOCUMENT.

DIMENSIONS: mm	TOLERANCES UNLESS OTHERWISE SPECIFIED:	DWG: K. WHITAKER 22FEB2005	CHK: S. RIDGILL 22FEB2005	NAME: S. RIDGILL 22FEB2005
0 PLC ± -	1 PLC ± -	2 PLC ± 0.13	3 PLC ± -	4 PLC ± -
ANGLES ± -				
MATERIAL: SEE TABLE	FINISH: SEE TABLE	WEIGHT: -	SIZE: A1	CAGE CODE: 00779
CUSTOMER DRAWING		SCALE: 4:1	SHEET: 1 of 1	REV: J3

STE TE Connectivity

PIN HEADER ASSEMBLY, RIGHT ANGLE MOUNT, 6 POSITION, UNIVERSAL MATE-N-LOK™