

Atmel LED Drivers

MSL1061/MSL1064

6-string PWM LED Driver with Digitally Compensated, 1.1MHz, 48V Boost Regulator, $\pm 1.5\%$ Current Balance, I²C Interface

Datasheet Brief



Atmel LED Drivers-MSL 106 1/MSL 1064

6-string PWM LED Driver with Digitally Compensated, 1.1MHz, 48V Boost Regulator, $\pm 1.5\%$ Current Balance, I²C Interface

General Description

The Atmel[®] LED Drivers-MSL 1061 and MSL 1064 are LED drivers with integrated boost regulators capable of driving six LED strings at 30mA up to 48V for lighting applications to 8W, allowing up to 72 LEDs per driver backlighting applications.

The MSL 1061/64 incorporates a current mode PWM boost regulator with 50V internal switch and a wide, 4.75V to 36V input voltage range. The 1.1MHz switching frequency uses a small-sized inductor and output capacitors while maintaining high efficiency and low ripple voltage and noise. The boost regulator uses digital control and requires no external compensation.

An I²C/SMB compatible serial interface operates up to 1MHz, giving access to internal 8-bit PWM dimming and 4-bit analog current adjustment for 12-bit current control. Individual string enable and fault reporting are available. The MSL 1061 operates with one of four I²C slave addresses selected from a single input pin (AD0), whereas the lower cost MSL 1064 has one fixed I²C slave address.

The MSL 1061/64 is also easy to employ without using an I²C interface, dimming with an external PWM signal.

Analog dimming of LED string current is available for use with an ambient light sensor (ALS) and/or temperature management with a thermistor or IC temperature sensor.

The MSL 1064 comes in a 5 x 5mm, 24-pin TQFN package, and the MSL 1061 in a 5 x 5mm, 28-pin TQFN. Both packages are lead-free, halogen-free and RoHS-compliant, and operate over a -40°C to 85°C temperature range.

Applications

Long Life, Efficient LED Backlighting for:

- Notebook PCs and Desktop PC Monitors
- Medical and Industrial Instrumentation
- Portable Media Players (PMPs)
- Automotive Audio-visual Displays

Traffic Lights

Signage

Ordering Information

PART	DESCRIPTION	PACKAGE
MSL1061AV	6-ch LED driver	28-pin, 5x5x0.75mm TQFN
MSL1064AW	6-ch LED driver	24-pin, 5x5x0.75mm TQFN

Atmel LED Drivers-MSL 1061/MSL 1064

6-string PWM LED Driver with Digitally Compensated, 1.1MHz, 48V Boost Regulator, $\pm 1.5\%$ Current Balance, I²C Interface

Key Features

- Drives 6 Strings of up to 12 LEDs per String
- Drives 72 White LEDs at 30mA for 8W Backlight
- Better than $\pm 1.5\%$ String-to-string Current Accuracy
- 4.75V to 36V Wide Input Supply Range
- Integrated Boost Regulator with 50V Internal Switch
- 1.1MHz Current Mode PWM Boost for Low Noise
- Up to 92% Boost Converter Efficiency
- Internal, Automatic Power Supply Management
- Adjustable LED Current up to 30mA per String
- String Outputs can be Paralleled for >30mA LEDs
- 256:1 Internal PWM Dimming Range Through I²C
- 16:1 Internal Analog Dimming Range Through I²C
- 12-Bit Total Internal PWM + Analog Dimming Range
- ALS Interface for Automatic Brightness Setting
- NTC Interface for Temperature Derating
- Individual Open-circuit and Short-circuit Fault Detection
- Faults Automatically Disable the Faulty String
- Fault Reporting and Fault Reset Through I²C/SMB
- FLTB Logic Output Indicates Faults
- Enable Input Simplifies Operation Without I²C/SMB
- PWM Input Synchronizes PWM to System Clock and Allows Logic PWM Control Without I²C
- Adjustable Over-voltage Protection
- Serial I²C/SMB Compatible Interface to 1MHz
- Four selectable I²C Slave Addresses (MSL 1061)
- GUI Software for Ease of Evaluation
- -40°C - +85°C Operating Temperature Range
- Lead-free, Halogen-free, RoHS-compliant Package

Application Circuit

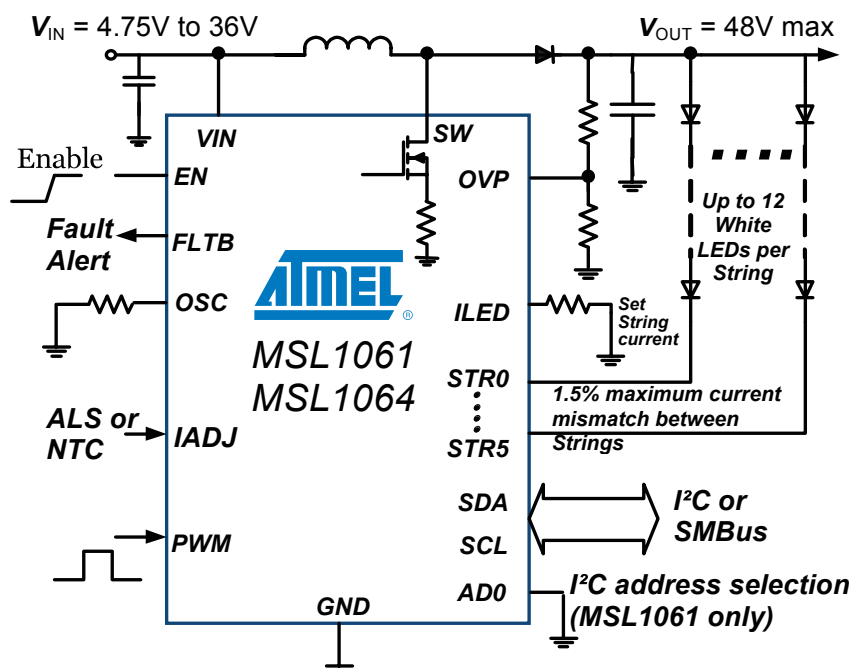



Quick Start Guide

This section summarizes for quick evaluation the capabilities of, and differences between, the MSL 1061 and MSL 1064.

The MSL 1061 and MSL 1064 are LED string drivers with integrated boost regulators, which power, monitor, and dim multiple LEDs at high efficiency for backlighting and signage applications. Each MSL 1061/64 contains six outputs, each capable of sinking up to 30mA through a string of series-connected LEDs.

How Many LEDs Can the Atmel LED Drivers-MSL 1061/64 Drive?

The MSL 1061/64 includes 6 current sinks (STR0 through STR5) that each control the LED current of multiple series-connected white LEDs. Any combination of the 6-strings may be enabled, and not all the strings need to be used.

Make sure that each enabled string contain the same number of the same type of LED so that the total voltage drop for each string is the same because the single boost regulator supplies power to all six strings. Use a single MSL 1061/64 LEDs of a single color/chemistry, such as white LED backlighting or single-color signage. For multicolor applications (e.g. RG, RGB, RGGB, RGBA), use separate MSL 1061/64s per LED color/chemistry type. Each MSL 1061/64 manages its integrated boost regulator to optimize efficiency for its strings of identical LEDs with matched electrical characteristics.

The maximum number of LEDs allowed in a string is determined by the maximum voltage rating of the boost regulator's internal power FET, which is 50V minus 2V for switching noise transients, leaving 48V. The FET is protected by the OVP trip, which has a 2% voltage tolerance, plus another 1% for the external setting resistors R8 and R9 (Figure 6 on page 15) reducing the maximum voltage to 46.5V. The total voltage needed to drive a string is the forward voltage drop across the desired LED strings, plus the headroom needed across a string output's current sink (600mV) to maintain regulation, plus the boost regulator's rectifier forward voltage (normally under 900mV) leaves $46.5V - 0.6V - 0.9V = 45V$ maximum for the LED string. The number of LEDs that the MSL 1061/4 can drive per string is $45V / \{\text{maximum LED forward voltage per LED}\}$, or 12 LEDs per string using 3.75V maximum forward voltage LEDs.

Differences Between Atmel LED Drivers-MSL 1061/64

Use the MSL 1061 for applications where multiple drivers are connected to a single I²C bus such as RGB and RGGB lighting. Use the lower cost MSL 1064 for single-driver applications, and multi-driver applications that do not require all drivers on the same I²C interface (Table 1).

Atmel LED Drivers-MSL 106 1/MSL 1064

6-string PWM LED Driver with Digitally Compensated, 1.1MHz, 48V Boost Regulator, $\pm 1.5\%$ Current Balance, I²C Interface

Table 1. Atmel LED Drivers-MSL1061 and MSL1064 Comparison

FEATURE	MSL1061	MSL1064	APPLICATION AND SUITABILITY
I ² C interface	4 selectable slave addresses by AD0 pin (0x60, 0x61, 0x62, 0x63)	1 fixed slave address (0x62)	Only one MSL1064 is uniquely addressed on an I ² C bus
Package	28-lead, 5mm x 5mm TQFN, 0.5mm pitch	24-lead, 5mm x 5mm TQFN, 0.65mm pitch	
IPC-2221A-2003 compliance	0.2mm min gap between SW pins and adjacent conductors. Compliant to 100V with board coating, 15V without coating	0.6mm min total gap between SW pins and adjacent conductors. Compliant to 100V with or without board coating	If compliance is necessary use the MSL1064 or MSL1061 with board coating.

Capabilities With and Without Using the Serial Interface

MSL1061/64 operates as stand alone LED drivers with full digital (PWM) and analog (DAC) LED brightness control and fault reporting through I/O controls. Alternatively, LED dimming and fault reporting is managed over an I²C or SMB serial interface, allowing software/firmware LED intensity control. More detailed fault management reporting and software controlled shutdown (Table 2) via the serial interface.

Table 2. Atmel LED Drivers-MSL1061/64 Stand Alone Capabilities and I²C Controlled Features

FUNCTION	CONTROLS AVAILABLE ON PINS	ADDITIONAL CONTROLS AVAILABLE VIA I ² C
Global on/off control	EN pin (Table 3 on page 9)	Run mode/sleep mode
Individual LED string on/off control	Not available	String enables register
Analog LED current adjustment	ILED pin (Table 3 on page 8)	Current setting register
PWM LED current adjustment	PWM pin (Table 3 on page 8)	PWM frequency register PWM duty ratio register
Ambient light sensor (ALS) and/or auto-matic temperature LED current adjustment	IADJ pin (Table 3 on page 9)	Current setting register
Fault monitoring	FLTB pin indicates open-string, shorted-string, and over-temperature faults	Status register identifies open/short circuit and over-temperature faults to individual strings



Packages and Pin Connections

Atmel LED Drivers-MSL 1061/64 – 24-pin, 5mm x 5mm x 0.75mm TQFN package with 0.65mm lead pitch

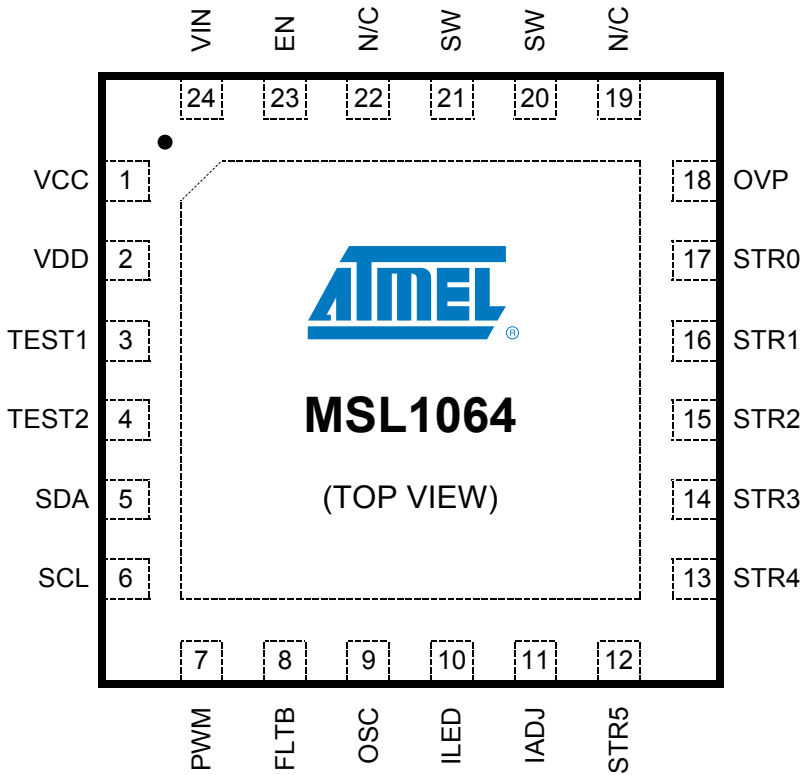
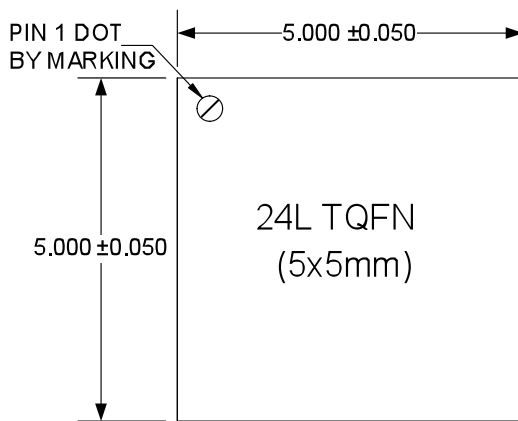
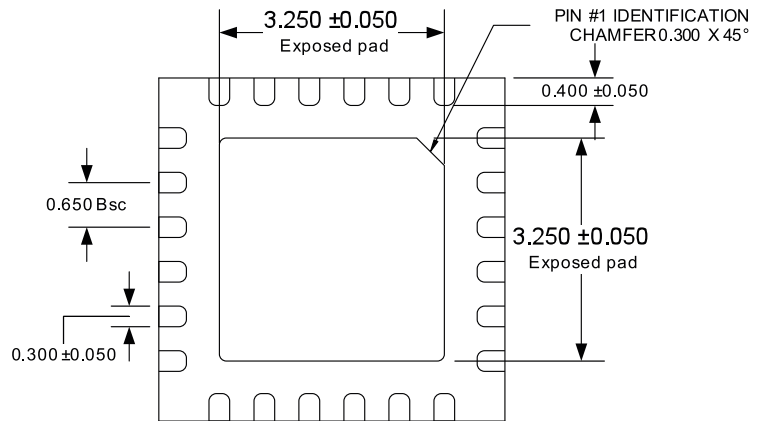

Figure 1. 24-pin, 5mm x 5mm x 0.75mm TQFN (0.65mm pin pitch) with Exposed Pad



TOP VIEW



BOTTOM VIEW

A	TQFN	
	MAX.	0.800
NOM.	0.750	
MIN.	0.700	

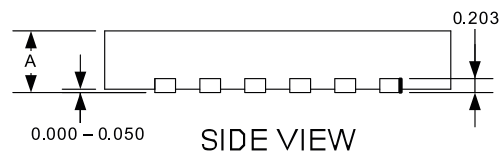

SIDE VIEW

Figure 2. 24-pin TQFN Package Dimensions

Atmel LED Drivers-MSL 1061/MSL 1064

6-string PWM LED Driver with Digitally Compensated, 1.1MHz, 48V Boost Regulator, $\pm 1.5\%$ Current Balance, I^2C Interface

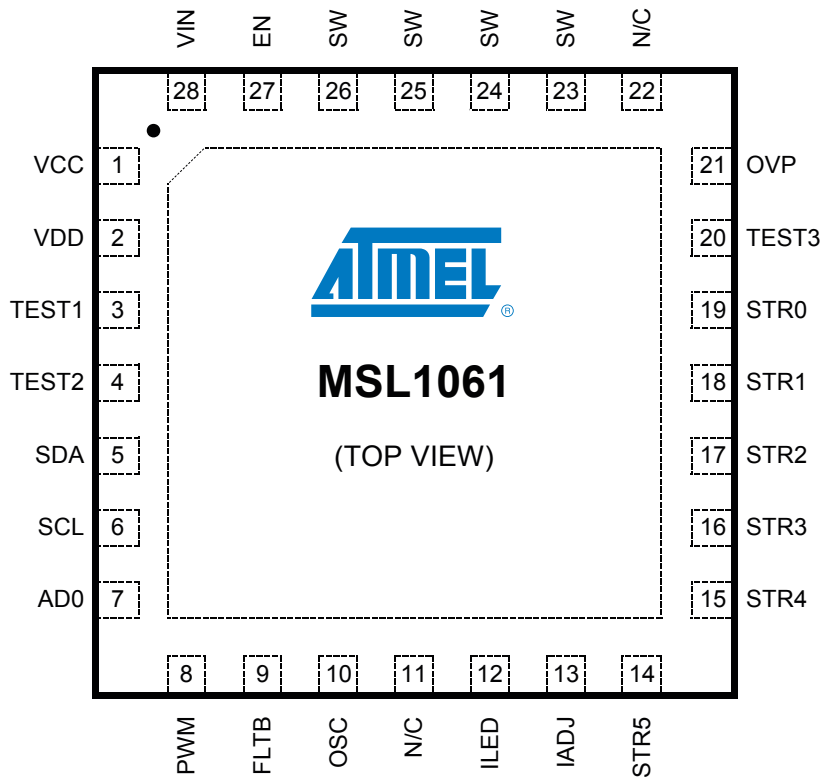
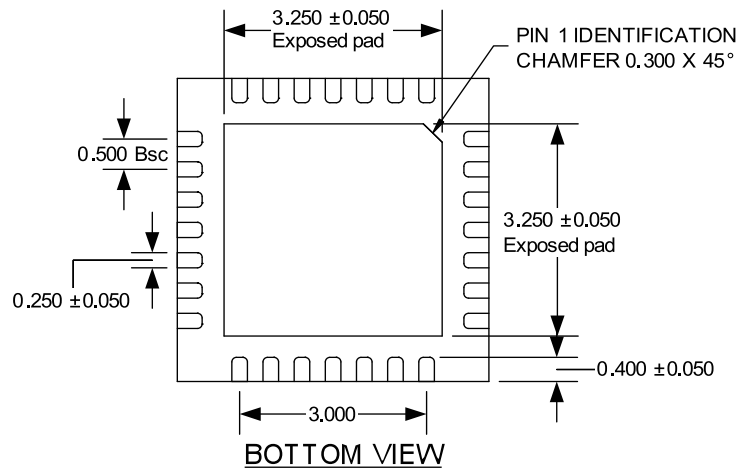
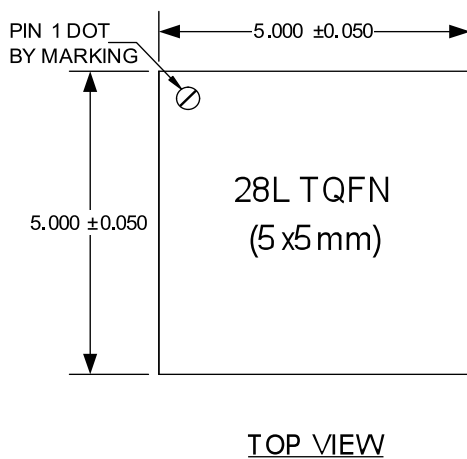
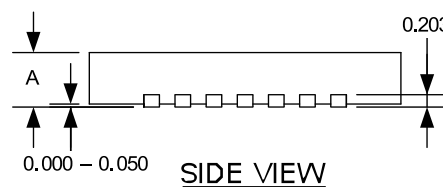

Figure 3. 28-pin, 5mm x 5mm x 0.75mm TQFN (0.5mm pin pitch) with Exposed Pad



		TQFN
A	MAX	0.800
	NOM	0.750
	MIN	0.700

Figure 4. 28-pin TQFN Package Dimensions





Pin Descriptions

Table 3. Pin Assignments

PIN NAME	MSL1061	MSL1064	PIN DESCRIPTION
VCC	1	1	6V internal linear regulator output VCC powers the internal power FET switch driver. Bypass VCC to GND either with a 10 μ F or greater ceramic capacitor, or with a 10 μ F or greater tantalum capacitor in parallel with a 1 μ F ceramic capacitor. If the voltage at VIN is less than 6.5V, connect VCC directly to VIN to bypass the internal linear regulator, and power the driver directly from VIN
VDD	2	2	2.9V internal linear regulator output VDD powers internal logic. Bypass VDD to GND with at least a 4.7 μ F ceramic capacitor
TEST1	3	3	Factory test connection. Leave unconnected
TEST2	4	4	Factory test connection. Connect to GND
SDA	5	5	I²C serial data I/O SDA is the data I/O for the I ² C serial interface
SCL	6	6	I²C serial clock input SCL is the clock input for the I ² C serial interface
AD0	7	-	I²C slave ID selection input For MSL1061, connect AD0 to GND, VDD, SCL, or SDA to set the I ² C slave ID to 0x60, 0x61, 0x62, or 0x63. The MSL1064 I ² C slave ID is fixed at 0x62, and is not user-selectable
PWM	8	7	PWM control input Drive PWM with a PWM signal up to 40kHz to pulse-width-modulate the LED current
FLTB	9	8	Fault indication output (active low) FLTB sinks current to GND whenever the MSL1061/64 detects a fault. Once a fault is detected, FLTB remains low until EN is toggled low/high, input power is cycled off/on, or the fault status is reset through the I ² C interface.
OSC	10	9	Oscillator control input Connect a 115k Ω , 1% resistor from OSC to GND to set the internal oscillator frequency to 11MHz and the boost regulator switching frequency to 1.1MHz
TEST3	11	-	Factory test connection with internal 1.8k Ω pull-up to VDD. Leave unconnected
ILED	12	10	Maximum LED current control input Connect a resistor from ILED to GND to set the full-scale LED string current. For example, connect a 100k Ω resistor to GND to set a 20mA sink current through each LED string

Atmel LED Drivers-MSL 1061/MSL 1064

6-string PWM LED Driver with Digitally Compensated, 1.1MHz, 48V Boost Regulator, $\pm 1.5\%$ Current Balance, I²C Interface

PIN NAME	MSL1061	MSL1064	PIN DESCRIPTION
IADJ	13	11	Analog LED current dimming input Apply a voltage between 0V to 1.22V to linearly control the LED current from 0 to 100%. Connect IADJ to VDD if unused
STR5	14	12	LED string 5 current sink output Connect the cathode of LED String 5 to STR5. Connect STR5 to GND if unused
STR4	15	13	LED string 4 current sink output Connect the cathode of LED String 4 to STR4. Connect STR4 to GND if unused
STR3	16	14	LED string 3 current sink output Connect the cathode of LED String 3 to STR3. Connect STR3 to GND if unused
STR2	17	15	LED string 2 current sink output Connect the cathode of LED String 2 to STR2. Connect STR2 to GND if unused
STR1	18	16	LED string 1 current sink output Connect the cathode of LED String 1 to STR1. Connect STR1 to GND if unused
STR0	19	17	LED string 0 current sink output Connect the cathode of LED String 0 to STR0. Connect STR0 to GND if unused
OVP	21	18	Overvoltage detection input Connect a resistive voltage divider from the boost output voltage to OVP to set the overvoltage protection set point. OVP threshold is 1.28V
N/C	22	19	No internal connection. Leave unconnected
SW	23, 24, 25, 26	20, 21	Drain of the internal boost power MOSFET switch Connect all SW pins together and to the boost regulator inductor and rectifier
N/C	-	22	No internal connection. Leave unconnected
EN	27	23	Enable input (active high) Drive EN high to turn on the MSL1061/64, and drive it low to turn it off. For automatic startup, connect EN to VIN through a 100k Ω resistor
VIN	28	24	Supply voltage input Connect the input supply voltage to VIN. VIN powers the internal linear regulator that powers VCC. Bypass VIN to GND with a 1 μ F or greater ceramic capacitor
GND	Exposed pad	Exposed pad	Ground



Absolute Maximum Ratings

Voltage (With Respect to GND Exposed Pad on Package Underside)

VIN.....	-0.3V to +40V
VCC, EN.....	-0.3V to +8V
VDD, OVP, IADJ, FLT, ILED, SDA, SCL, AD0, OSC, PWM.....	-0.3V to +3.6V
SW.....	-0.3V to +50V
STR0, STR1, STR2, STR3, STR4, STR5.....	-0.3V to +45V

Current (Into Pin)

SW.....	±3A
STR0, STR1, STR2, STR3, STR4, STR5.....	±35mA
All other pins.....	±20mA

Continuous Power Dissipation at 70°C

24-Pin TQFN (see Note 8, Note 9).....	2286mW
28-Pin TQFN (see Note 8, Note 9).....	2286mW

Ambient Operating Temperature Range $T_A = T_{MIN}$ to T_{MAX} -40°C to +85°C

Junction Temperature +125°C

Storage Temperature Range..... -65°C to +125°C

Lead Soldering Temperature, 10s.....+300°C

Atmel LED Drivers-MSL 1061/MSL 1064

6-string PWM LED Driver with Digitally Compensated, 1.1MHz, 48V Boost Regulator, $\pm 1.5\%$ Current Balance, I²C Interface

Electrical Characteristics

(Circuit of Figure 6, $V_{VIN} = 12V$, default register settings of Table 7, $T_A = -40^\circ C$ to $+85^\circ C$, unless otherwise noted. Typical values are at $T_A = +25^\circ C$) (Note 1)

PARAMETER	CONDITIONS AND NOTES	MIN	TYP	MAX	UNIT
DC ELECTRICAL CHARACTERISTICS					
VIN operating supply voltage	$V_{VIN} = V_{VCC}$	4.75		6.5	V
	VCC unconnected	6.5		36	V
VIN quiescent supply current	$V_{EN} = 3V, V_{PWM} = 0V$	$V_{VIN} = 12V$	4	14	mA
		$V_{VIN} = 6V, V_{VCC} = 6V$	4	14	mA
VIN shutdown supply current	$V_{EN} = V_{PWM} = 0V$	1	4	10	μA
VCC output voltage		5.6	6	6.3	V
VCC line regulation	$6.5V < V_{VIN} < 36V$	1	2	5	mV
VCC dropout voltage	$V_{VIN} = 6V, I_{VCC} = 5mA, V_{PWM} = 0V$	100	300	550	mV
VCC short-circuit current	$V_{VCC} = 0V$	30	80	150	mA
VCC UVLO threshold	V_{VCC} rising, hysteresis = 150mV	4.1	4.3	4.5	V
VDD output voltage	$I_{VDD} = 1mA$	2.7	2.9	3.1	V
VDD short-circuit current	$V_{VDD} = 0V$	10	35	60	mA
VDD UVLO threshold	V_{VDD} rising, hysteresis = 80mV	2.4	2.5	2.6	V
Thermal shutdown threshold (rising)			135		$^\circ C$
Thermal shutdown hysteresis			10		$^\circ C$

PARAMETER	CONDITIONS AND NOTES	MIN	TYP	MAX	UNIT
DC ELECTRICAL CHARACTERISTICS - LED CURRENT CONTROL STR0 TO STR5					
ILED regulation voltage	$R5 = 100k\Omega$	1.195	1.22	1.245	V
STR0 to STR5 full scale sink current	$V_{STRn} = 1V, R5 = 100k\Omega, V_{IADJ} = V_{PWM} = 3V$	19.7	20	20.3	mA
STR0 to STR5 maximum sink current	$V_{STRn} = 1V, R5 = 60k\Omega, V_{IADJ} = V_{PWM} = 3V$ (Note 10)	30			mA
STR0 to STR5 current matching	$V_{STRn} = 1V, R5 = 100k\Omega, V_{PWM} = 3V$ (Note 11)			1.5	%
STR0 to STR5 leakage current	$V_{EN} = 0V, V_{STRn} = 40V$		0.1	1	μA
	$V_{EN} = 3V, V_{STRn} = 40V, V_{PWM} = 3V$		0.1	1	μA
STR0 to STR5 short circuit detection threshold		4	4.4	4.8	V
STR0 to STR5 open circuit detection threshold			0.1		V

PARAMETER	CONDITIONS AND NOTES	MIN	TYP	MAX	UNIT
DC ELECTRICAL CHARACTERISTICS - LOGIC I/Os					
EN logic high input voltage		2.3			V
EN logic low input voltage				0.8	V
EN logic input current	$V_{EN} = 3V$			20	μA



PARAMETER	CONDITIONS AND NOTES	MIN	TYP	MAX	UNIT
EN logic input series resistance	Between EN input package pin and internal Zener clamp		10.5		kΩ
EN logic input Zener clamp			5.8		V
SCL, SDA, AD0, PWM logic high input voltage		2			V
SCL, SDA, AD0, PWM logic low input voltage				0.9	V
SDA, SCL, AD0 input capacitance			10		pF
SDA output low voltage	Sinking 6mA			0.4	V
FLT output low voltage	Sinking 1mA		0.1	0.2	V
IADJ, FLT, PWM, SCL, SDA, AD0 leakage current				10	μA

PARAMETER	CONDITIONS AND NOTES	MIN	TYP	MAX	UNIT
DC ELECTRICAL CHARACTERISTICS - BOOST REGULATOR					
SW on resistance	$I_{SW} = 100\text{mA}$		0.4	0.6	Ω
SW current limit			2		A
OSC regulation voltage	$R4 = 115\text{k}\Omega \pm 1\%$	1.195	1.22	1.245	V
STR0-STR5 boost regulation voltage	$R5 = 100\text{k}\Omega$, PWM=100% (Note 12)		600		mV
OVP threshold	V_{OVP} rising	1.25	1.28	1.31	V
OVP hysteresis			60		mV
OVP leakage current	$V_{OVP} = 3.6\text{V}$			1	μA

PARAMETER	CONDITIONS AND NOTES	MIN	TYP	MAX	UNIT
AC ELECTRICAL CHARACTERISTICS					
PWM input frequency	INTPWM bit D3=0 in control register to select external PWM input to be used for direct LED string dimming control	0		50	kHz
PWM input duty ratio		0		100	%
PWM input minimum string on time			14		μs
PWM input minimum string off time			3.2		μs
PWM input frequency, external PWM clock mode	INTPWM bit D3=1, EXTCLK bit D2=1 in control register to select external PWM input to be used as clock for internal PWM dimming control	0		12	MHz
PWM input duty ratio, external PWM clock mode		30		70	%
PWM frequency (internal oscillator)	$R4 = 115\text{k}\Omega \pm 1\%$, INTPWM bit D3=1, EXTCLK bit D2=0 in control register to select internal oscillator to be used as clock for internal PWM dimming control	9	11	12	MHz
Boost regulator switching frequency	$R4 = 115\text{k}\Omega \pm 1\%$	0.99	1.1	1.21	MHz
Boost regulator maximum duty ratio	$R4 = 115\text{k}\Omega \pm 1\%$	89	92		%
Boost regulator startup time			100	120	ms

Atmel LED Drivers-MSL 1061/MSL 1064

6-string PWM LED Driver with Digitally Compensated, 1.1MHz, 48V Boost Regulator, $\pm 1.5\%$ Current Balance, I²C Interface

PARAMETER	SYMBOL	CONDITIONS AND NOTES	MIN	TYP	MAX	UNIT
I²C SWITCHING CHARACTERISTICS						
SCL clock frequency	$1/t_{SCL}$	TOEN bit D1=0 in control register to disable bus timeout	0		1000	kHz
		TOEN bit D1=1 in control register to enable bus timeout	0.066			
Bus time-out period	$t_{TIMEOUT}$		15	25		ms
STOP to START condition bus free time	t_{BUF}		0.5			μ s
Repeated START condition hold time	$t_{HD:STA}$		0.26			μ s
Repeated START condition set-up time	$t_{SU:STA}$		0.26			μ s
STOP condition set-up time	$t_{SU:STOP}$		0.26			μ s
SDA data hold time	$t_{HD:DAT}$		5			ns
SDA data valid acknowledge time	$t_{VD:ACK}$	(Note 3)	0.05		0.55	μ s
SDA data valid time	$t_{VD:DAT}$	(Note 4)	0.05		0.55	μ s
SDA data set-up time	$t_{SU:DAT}$		100			ns
SCL clock low period	t_{LOW}		0.5			μ s
SCL clock high period	t_{HIGH}		0.26			μ s
SDA, SCL fall time	t_F	(Note 5, Note 6)			120	ns
SDA, SCL rise time	t_R				120	ns
SDA, SCL input suppression filter period	t_{SP}	(Note 7, Note 10)		50		ns

Note 1. All parameters are tested at $T_A=25^\circ\text{C}$, unless otherwise noted. Specifications at temperature are guaranteed by design

Note 2. Minimum SCL clock frequency is limited by the bus timeout feature, which resets the serial bus interface if either SDA or SCL is held low for $t_{timeout}$. Disable the bus timeout feature for DC operation

Note 3. $t_{VD:ACK}$ = SCL LOW to SDA (out) low acknowledge time

Note 4. $t_{VD:DAT}$ = minimum SDA output data-valid time following SCL low transition

Note 5. A master device must internally provide an SDA hold time of at least 300ns to ensure an SCL low state

Note 6. The maximum SDA and SCL rise times is 300ns. The maximum SDA fall time is 250ns. This allows series protection resistors to be connected between SDA and SCL inputs and the SDA/SCL bus lines without exceeding the maximum allowable rise time

Note 7. MSL1061/64 includes input filters on SDA, SCL, and AD0 inputs that suppress noise less than 50ns

Note 8. Subject to thermal dissipation characteristics of the device

Note 9. When mounted according to JEDEC JEP149 and JESD51-12 for a two-layer PCB, $\theta_{JA} = 24.1^\circ\text{C/W}$, and $\theta_{JC} = 2.7^\circ\text{C/W}$

Note 10. Guaranteed by design and characterization. Not production tested

Note 11. STR0 to STR5 current matching is the difference of any one string current and the average of all string currents divided by the average of all string currents

Note 12. The MSL1061/64 selects the string (STR0 through STR5) with the lowest voltage to control the boost regulator voltage



Block Diagram

The block diagram for the 28-pin MSL 1061 is shown in Figure 5. The differences for the 24-pin MSL 1064 are that the MSL 1064 provides only two pins for SW instead of four pins on the MSL 1061, and the ADO pin is not pinned out but is instead bonded internally to SCL. The MSL 1061 I²C slave address is selected using ADO from one of the four address pairs, 0xC0/0xC1 - 0xC6/0xC7, whereas the MSL 1064 I²C slave address is fixed at 0xC4/0xC5.

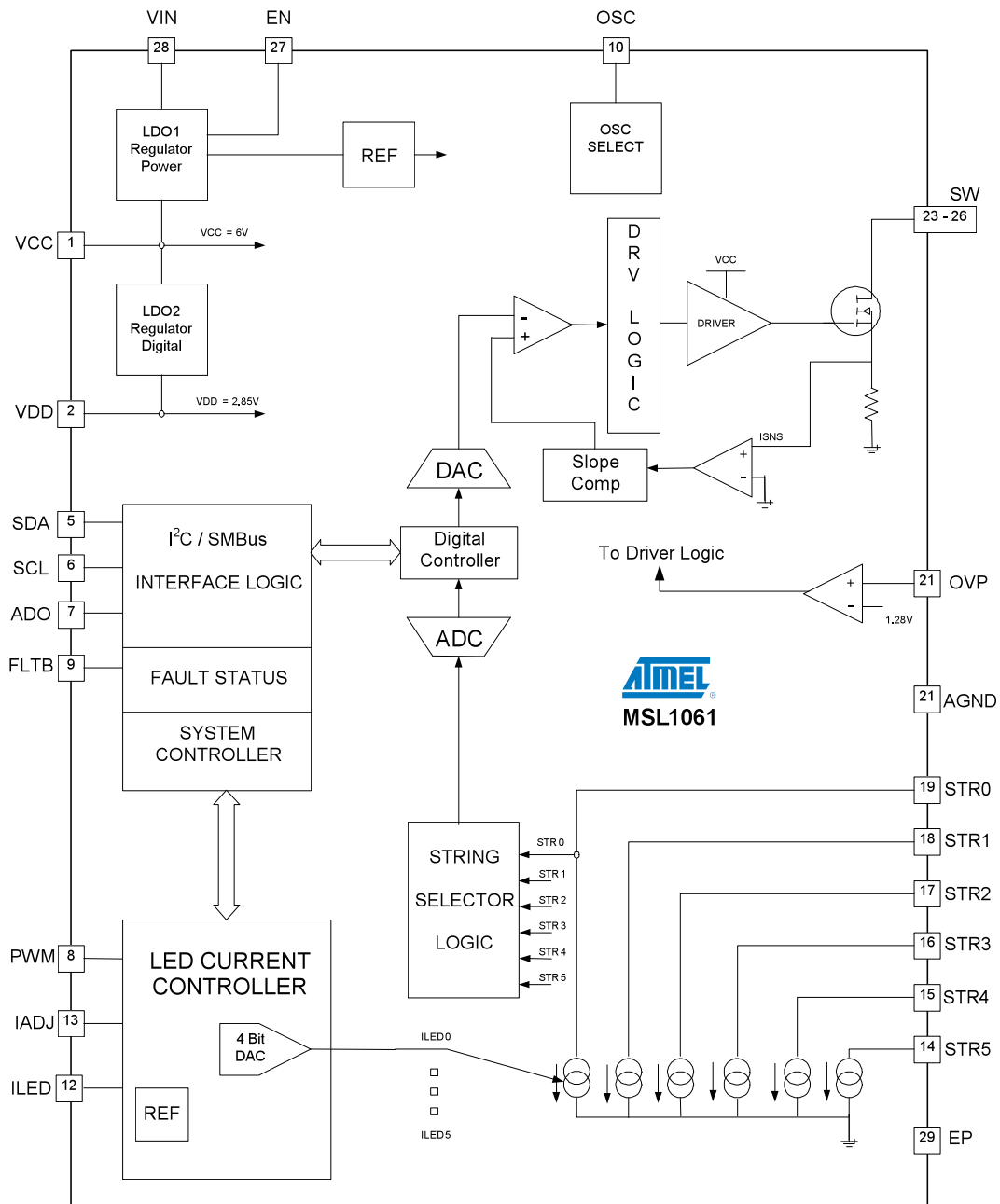

Figure 5. Atmel LED Driver-MSL1061 Block Diagram

Typical Application Circuit

Figure 6. Backlight Example Driving 60 White LEDs

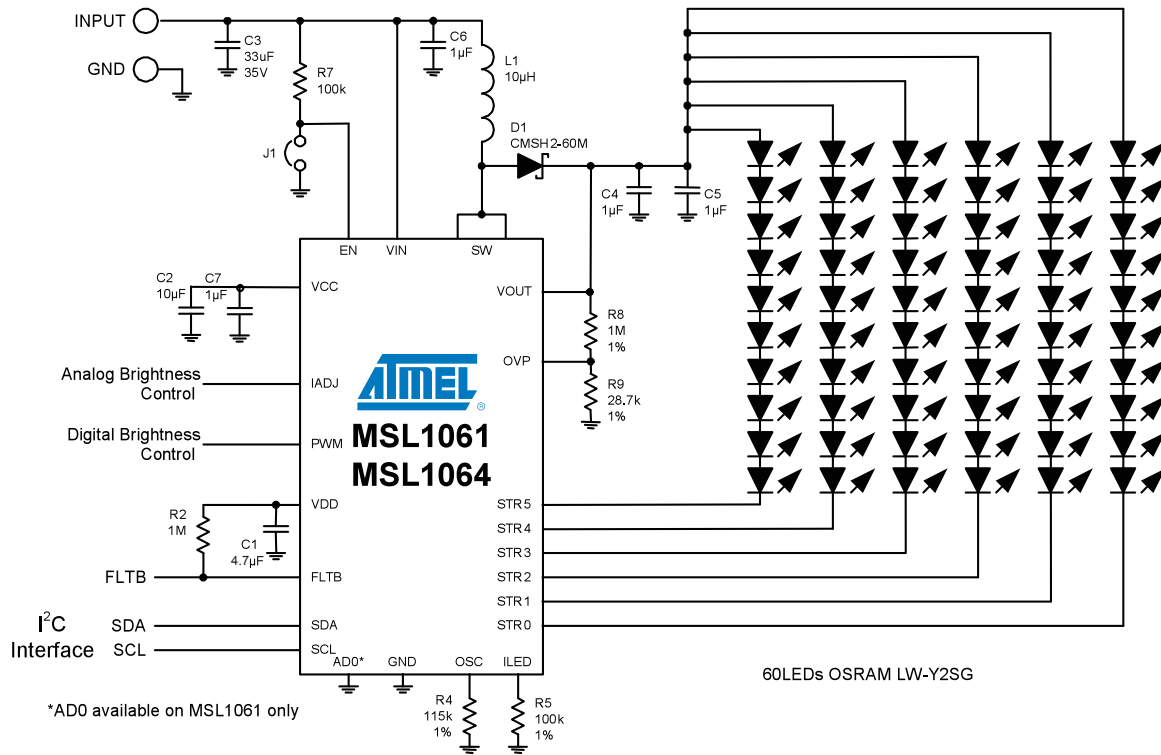

Table 4. Typ. Application Circuit Parameters

PARAMETER	VALUE
Minimum input voltage	4.75V
Maximum input voltage (set by minimum LEDs string voltage)	30V
Number of LEDs	60
Number of LED strings	6
Number of LED per string	10
LED forward current (set by R5)	20mA
White LED	Osram LW-Y3SG
Minimum LED forward voltage	2.9V
Typical LED forward voltage	3.3V
Maximum LED forward voltage	3.6V
Minimum LED string voltage	29V
Maximum LED string voltage	36V
Oscillator frequency (set by R4)	1.1MHz
Overvoltage protection (OVP) trip point (set by R8 and R9)	45.9V

Table 5. Typ. Application Circuit Bill of Materials

COMPONENT	DESCRIPTION	VENDOR PART NUMBER
C4, C5, C6, C7*	1µF, 50V, X7R	
C2	10µF, 10V, X7R or tantalum (see note)	
C3	33µF, 35V, X7R	
C1	4.7µF, 6.3V, X7R	
R8	1MΩ, 1%	
R9	28.7kΩ, 1%	
R4	115kΩ, 1%	
R5	100kΩ, 1%	
R7	100kΩ, 5%	
R2	1MΩ, 5%	
L1	10µH, 1.7A	Sumida CDRH6D28-100
D1	60V, 2A Schottky	Central Semi CMSH2-60M
LEDs	60 x 30mA LED	Osram LW-Y2SG
LED driver	MSL1060	MSL1060

* Note: C7 is only required if tantalum capacitor is used for C2



Detailed Description

The MSL 106 1/64 is an LED driver with integrated boost regulator for driving an array of LEDs with up to 8W of power. The I²C/SMB serial interface, logic controls, and fault management make the MSL 106 1/64 especially suited to drive up to 72 white LEDs for portable device backlighting. It is also ideal for industrial lighting and signage applications, and can, for example, drive a 6 string x 18 series LED array totaling 108 red LEDs (2.5V LED forward voltage drop).

The MSL 106 1/64 includes six current sinks (STR0 through STR5) that each control the LED current of series-connected LEDs. A built-in step-up (boost) regulator supplies power to the LEDs. The MSL 106 1/64 controls the output voltage of the boost regulator such that all LED strings have sufficient voltage to maintain regulated LED current. This control loop operates automatically without any user interaction or set-up.

Application Information

VCC and VDD Regulators

The MSL 106 1/64 includes two linear voltage regulators to generate the internal voltage rails, VDD and VCC. The regulators allow the MSL 106 1/64 to operate directly from the same higher voltage supply, VIN, which supplies the LED boost regulator. Use the VDD and VCC regulators only to power the MSL 106 1/64's internal circuitry, therefore do not draw any external current from them.

The VCC regulator generates a nominally 6V rail from VIN. VCC powers the boost regulator's power switch and the VDD regulator. Bypass VCC to GND either with a 10μF or greater ceramic capacitor or with a 10μF or greater tantalum capacitor in parallel with a 1μF ceramic capacitor.

In applications where there is a local 4.75V to 6.5V supply available, power VCC and VIN directly from this supply. In this case use this supply or a separate higher voltage supply to power the LED boost regulator. When using a higher voltage supply connect it to the inductor, L1 (Figure 6), and not to the MSL 106 1/64.

The VDD regulator generates a nominally 2.9V rail from VCC. VDD operates the internal low-voltage circuits. Bypass VDD to GND with a 4.7μF or greater capacitor.

Internal Oscillator - R4

The MSL 106 1/64 uses an internal oscillator with frequency set by resistor R4 from OSC to GND (Figure 6). Use 115kΩ ±1% resistance value for R4. This sets the internal LED dimming PWM frequency to 11MHz and the boost regulator PWM frequency to 1.1MHz. When using different values for R4 the MSL 106 1/64 performance is not guaranteed.

Setting the Full-scale LED String Current - R5

R5 sets the full-scale static LED current for all enabled strings (Figure 6) from ILED to GND. The maximum full-scale LED current is 30mA. The equation for calculating external resistor R5 (Figure 6) to set the full-scale LED string current I_{ILED} is:

$$I_{ILED} = \frac{2000}{R5}$$

where R5 is in kilohms and ILED is in milliamperes.

A value of 100kΩ for resistor R5 sets 20mA full-scale LED current. The minimum allowed value for R5 is 66.7kΩ, which sets 30mA full-scale LED current.

Reduce the static LED current from full-scale using the LED string current register. This register reduces LED current proportional to the 4-bit IDAC register.

Atmel LED Drivers-MSL 1061/MSL 1064

6-string PWM LED Driver with Digitally Compensated, 1.1MHz, 48V Boost Regulator, $\pm 1.5\%$ Current Balance, I²C Interface

Boost Regulator Components

The boost regulator is internally compensated, includes an internal high voltage power switch, and requires only an inductor, rectifier, and bypass capacitors. The current-mode boost regulator operates in either continuous conduction mode (CCM) or discontinuous conduction mode (DCM). In CCM, the inductor current does not fall to zero when operating at full power, keeping inductor ripple current low and switching noise at a minimum. The boost regulator switching frequency is 1.1MHz set by the 115k Ω resistor R4 from OSC pin to GND (Figure 6). Select the inductor, rectifier diode, and output capacitors per the following guidelines.

To minimize losses in the rectifier, choose one with fast switching and low forward voltage drop. Ensure that the rectifier can withstand a reverse voltage equal to the regulator output voltage. The average forward current is equal to the total LED string current (for example 6 strings \times 30mA = 180mA), while the peak current is equal to the inductor peak current (2A).

The boost output capacitor holds the voltage at the output of the boost regulator while the internal power switch is on and the rectifier is not conducting. Use ceramic capacitors for small size and high ripple current capacity, and derate them for operating voltage because of the voltage coefficient of capacitance which decreases the effective capacitance with increased operating voltage. Use two parallel-connected 1 μ F 100V X7R ceramic capacitors and a 10 μ H inductor with a 1.7A peak current rating.

Boost Supply Over-voltage Protection (OVP) - R8 and R9

The OVP input sets the boost regulator's output voltage upper limit, and protects the boost regulator from an open-circuit LED fault. Set the OVP voltage V_{TRIP} by resistors R8 and R9 (Figure 6):

$$V_{TRIP} = V_{OVP} \frac{(R8 + R9)}{R9}$$

where V_{OVP} = 1.28V, nominal.



Register Map Summary

Control the MSL1061/64 through an I²C interface using nine registers (Table 6). The power-up defaults (Table 7) are such that an MSL1061/64 operates as a standalone LED driver if the I²C interface is not used.

The Internal register addressing auto-increments through the register map allowing sequential reads or writes without needing to write separate addresses for each byte.

Table 6. Atmel LED Drivers-MSL1061/64 Register Map

REGISTER	FUNCTION	ADDRESS	REGISTER DATA							
			D7	D6	D5	D4	D3	D2	D1	D0
MSTRCNTRL	Run/sleep mode	0x00	-	-	-	-	-	-	-	SLEEP
CNTRL	PWM source, I ² C/SMB bus timeout, fault pin enable	0x01	-	-	-	-	INTPWM	EXTCLK	TOEN	FLTEN
-	UNUSED	0x02	WRITES TO THIS REGISTER ADDRESS ARE IGNORED, AND READS RETURN THE VALUE 0x00							
STATUS	Fault status summary	0x03	-	OTDET	SCDET	OCDET	-	-	-	FLTDET
OCSTATUS	Open circuit fault status	0x04	-	-	OC5	OC4	OC3	OC2	OC1	OC0
SCSTATUS	Short circuit fault status	0x05	-	-	SC5	SC4	SC3	SC2	SC1	SC0
PWMFREQ	PWM frequency prescaler	0x06	D7	D6	D5	D4	D3	D2	D1	D0
PWMDUTY	PWM duty ratio	0x07	D7	D6	D5	D4	D3	D2	D1	D0
-	UNUSED	0x08	WRITES TO THIS REGISTER ADDRESS ARE IGNORED, AND READS RETURN THE VALUE 0x00							
STREN	String enables	0x09	-	-	STR5EN	STR4EN	STR3EN	STR2EN	STR1EN	STR0EN
-	unused	0x0A	writes to this register address are ignored, and reads return the value 0x00							
-	unused	0x0B	writes to this register address are ignored, and reads return the value 0x00							
-	unused	0x0C	writes to this register address are ignored, and reads return the value 0x00							
-	unused	0x0D	writes to this register address are ignored, and reads return the value 0x00							
-	unused	0x0E	writes to this register address are ignored, and reads return the value 0x00							
-	unused	0x0F	writes to this register address are ignored, and reads return the value 0x00							
IDAC	LED string current	0x10	-	-	-	-	DAC3	DAC2	DAC1	DAC0

Atmel LED Drivers-MSL 1061/MSL 1064

6-string PWM LED Driver with Digitally Compensated, 1.1MHz, 48V Boost Regulator, $\pm 1.5\%$ Current Balance, I²C Interface

Register Map Power-up Defaults

Table 7. Atmel LED Drivers-MSL 1061/64 Register Power-up Defaults

REGISTER	POWER-UP CONDITION	ADDRESS	REGISTER DATA							
			D7	D6	D5	D4	D3	D2	D1	D0
MSTRCNTRL	Run mode	0x00	0	0	0	0	0	0	0	0
CNTRL	Fault detection is enabled I ² C bus timeout is disabled PWM internal 11MHz clock is used, prescaled by PWMFREQ PWM control is by PWM pin. PWMDUTY register is ignored	0x01	0	0	0	0	0	0	0	1
STATUS	No faults (open, short, or temperature) are detected	0x03	0	0	0	0	0	0	0	0
OCSTATUS	None of the six LED outputs STR0 to STR5 has an open circuit fault	0x04	0	0	0	0	0	0	0	0
SCSTATUS	None of the six LED outputs STR0 to STR5 has a short circuit fault	0x05	0	0	0	0	0	0	0	0
PWMFREQ	Internal PWM frequency is the maximum 43kHz	0x06	0	0	0	0	0	0	0	0
PWMDUTY	Internal PWM duty ratio is 0.39%	0x07	0	0	0	0	0	0	0	0
STREN	All of the six LED outputs STR0 to STR5 are enabled	0x09	0	0	1	1	1	1	1	1
IDAC	LED string current is 100% of the value programmed by resistor R5	0x10	0	0	0	0	1	1	1	1

**Atmel Corporation**

2325 Orchard Parkway
San Jose, CA 95131
USA

Tel: (+1)(408) 441-0311

Fax: (+1)(408) 487-2600

www.atmel.com

Atmel Asia Limited

Unit 01-5 & 16, 19F
BEA Tower, Millennium City 5
418 Kwun Tong Road
Kwun Tong, Kowloon
HONG KONG

Tel: (+852) 2245-6100

Fax: (+852) 2722-1369

Atmel Munich GmbH

Business Campus
Parking 4
D-85748 Garching b. Munich
GERMANY

Tel: (+49) 89-31970-0

Fax: (+49) 89-3194621

Atmel Japan

9F, Tonetsu Shinkawa Bldg.
1-24-8 Shinkawa
Chuo-ku, Tokyo 104-0033
JAPAN

Tel: (+81)(3) 3523-3551

Fax: (+81)(3) 3523-7581

© 2011 Atmel Corporation. All rights reserved. / Rev.: MEM-MSL 1061/64DB1-E-US_06-11

Atmel®, logo and combinations thereof, and others are registered trademarks or trademarks of Atmel Corporation or its subsidiaries. Other terms and product names may be trademarks of others.

Disclaimer: The information in this document is provided in connection with Atmel products. No license, express or implied, by estoppel or otherwise, to any intellectual property right is granted by this document or in connection with the sale of Atmel products. EXCEPT AS SET FORTH IN THE ATMEL TERMS AND CONDITIONS OF SALES LOCATED ON THE ATMEL WEBSITE, ATMEL ASSUMES NO LIABILITY WHATSOEVER AND DISCLAIMS ANY EXPRESS, IMPLIED OR STATUTORY WARRANTY RELATING TO ITS PRODUCTS INCLUDING, BUT NOT LIMITED TO, THE IMPLIED WARRANTY OF MERCHANTABILITY, FITNESS FOR A PARTICULAR PURPOSE, OR NON-INFRINGEMENT. IN NO EVENT SHALL ATMEL BE LIABLE FOR ANY DIRECT, INDIRECT, CONSEQUENTIAL, PUNITIVE, SPECIAL OR INCIDENTAL DAMAGES (INCLUDING, WITHOUT LIMITATION, DAMAGES FOR LOSS AND PROFITS, BUSINESS INTERRUPTION, OR LOSS OF INFORMATION) ARISING OUT OF THE USE OR INABILITY TO USE THIS DOCUMENT, EVEN IF ATMEL HAS BEEN ADVISED OF THE POSSIBILITY OF SUCH DAMAGES. Atmel makes no representations or warranties with respect to the accuracy or completeness of the contents of this document and reserves the right to make changes to specifications and products descriptions at any time without notice. Atmel does not make any commitment to update the information contained herein. Unless specifically provided otherwise, Atmel products are not suitable for, and shall not be used in, automotive applications. Atmel products are not intended, authorized, or warranted for use as components in applications intended to support or sustain life.