

STRAIGHT PLUG CRIMP OR SOLDER TYPE

R125.078.001

CABLE 5/50 D

Series : SMA

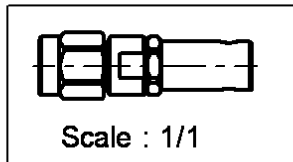
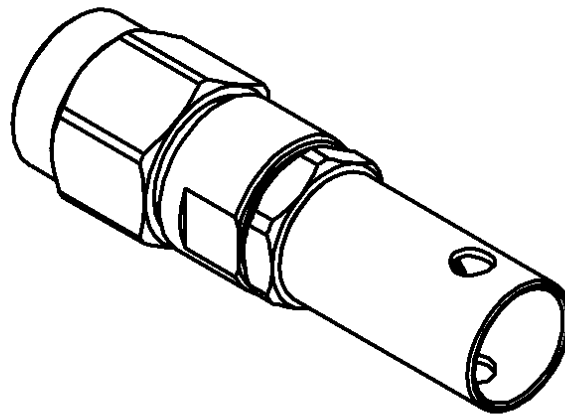
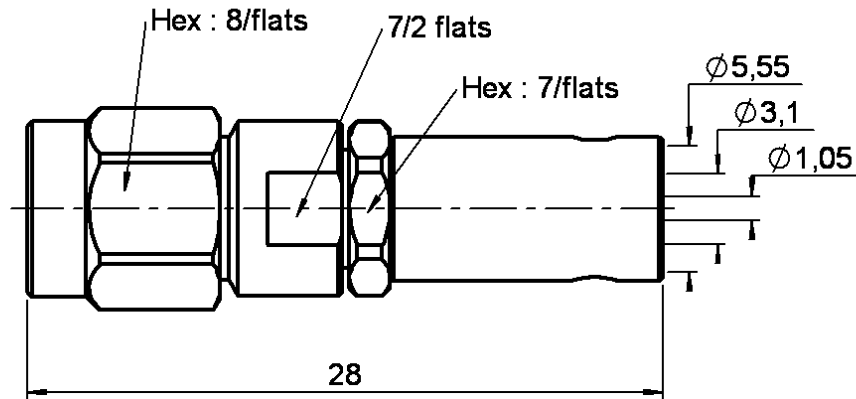

All dimensions are in mm.



COMPONENTS	MATERIALS	PLATINGS (µm)
BODY	STAINLESS STEEL	PASSIVATED .
CENTER CONTACT	BRASS	GOLD 1.3 OVER NICKEL 2
OUTER CONTACT	-	-
INSULATOR	PTFE	-
GASKET	SILICONE RUBBER	-
OTHERS PARTS	STAINLESS STEEL	PASSIVATED .
-	-	-
-	-	-

Issue : 0220 C

In the effort to improve our products, we reserve the right to make changes judged to be necessary.



STRAIGHT PLUG CRIMP OR SOLDER TYPE

R125.078.001

CABLE 5/50 D

Series : SMA

PACKAGING

Standard	Unit	Other
100	'W' option	Contact us

SPECIFICATION

ELECTRICAL CHARACTERISTICS

Impedance		50 Ω
Frequency		0-12.4 GHz
VSWR	1.15 +	0.010 x F(GHz) Maxi
Insertion loss		0.06 √F(GHz) dB Maxi
RF leakage	- (60 - F(GHz)) dB Maxi
Voltage rating		335 Veff Maxi
Dielectric withstanding voltage		1000 Veff mini
Insulation resistance		5000 MΩ mini

CABLE ASSEMBLY

Stripping	a	b	c	d	e	f
mm	3.50	7.00	13.5	0.00	10.0	0.00

Assembly instruction : **Crimp 10**

Recommended cable(s)

RG 223
RG 142
RG 400
KX 23
RG 142 FTX

Cable retention

- pull off **204** N mini
- torque **NA** N.cm

MECHANICAL CHARACTERISTICS

Center contact retention		
Axial force – Mating end		27 N mini
Axial force – Opposite end		27 N mini
Torque		NA N.cm mini

TOOLING

Part Number	Description	Hexagon
.	.	.
R282.235.011	CRIMPING DIES	5.41
R282.293.000	CRIMPING TOOL	-
R282.223.000	CRIMPING TOOL	5.41

Recommended torque		
Mating		100 N.cm
Panel nut		NA N.cm
Clamp nut		100 N.cm
A/F clamp nut		7.000 mm

Mating life		500 Cycles mini
Weight		5.243 g

OTHERS CHARACTERISTICS

-

ENVIRONMENTAL

Operating temperature		-65/+165 °C
Hermetic seal		NA Atm.cm3/s
Panel leakage		NA

Issue : 0220 C

In the effort to improve our products, we reserve the right to make changes judged to be necessary.

