

REVISION Y

DO NOT SCALE FROM THIS PRINT

NOTES:

1. $\text{\textcircled{C}}$ REPRESENTS A CRITICAL DIMENSION.
2. MINIMUM PUSHOUT FORCE: 1 LB[4.45N].
3. MAXIMUM ALLOWABLE BOW: .002[0.05] INCH/INCH AFTER ASSEMBLY.
4. POST HEIGHT VARIATION BETWEEN ANY TWO PINS: .005[0.13].
5. FOR ALL PINS: NO BAND MARKS ALLOWED IN POST AREA.
6. MINIMUM RETENTION FOR LOCKING CLIPS: .75LB[3.336N]
7. MEASURE AT BEND.
8. MAXIMUM PIN ROTATION IN BODY TO BE 2°.
9. ORDERS WILL BE PACKAGED ACCORDING TO THE SAMTEC PACKAGING EFFICIENCY STANDARDS (SPES) FOUND ON WWW.SAMTEC.COM.
10. ATTACH LABEL-4X2 TO EACH REEL.
11. TUBES ARE STANDARD PACKAGING.

SHF-1XX-01-X-D-XX-XX-XX

No OF POSITIONS
-02 THRU -25

LEAD STYLE
-01:

PLATING SPECIFICATION
-L: 10 μ " LIGHT SELECTIVE IN CONTACT AREA, MATTE TIN ON TAIL
-F: 3 μ " FLASH SELECTIVE GOLD IN CONTACT AREA, MATTE TIN ON TAIL
-S: 30 μ " SELECTIVE GOLD IN CONTACT AREA, MATTE TIN ON TAIL

PACKAGING
BLANK: TUBES (SEE NOTE 11)
-TR: TAPE & REEL (SEE NOTES 9 & 10)
-FR: FULL REEL QTY TAPE & REEL (SEE NOTES 9 & 10)

OPTION
-LC: LOCKING CLIP (NOT AVAILABLE WITH -RA)
-K: POLYIMIDE FILM (-SM ONLY) (AVAILABLE IN TAPE & REEL ONLY) (USE K-DOT-.256-.375-.005)

BODY HEIGHT
-TH: THROUGH HOLE (SEE FIG 1, SHT. 1)
-RA: RIGHT ANGLE (SEE FIG 2, SHT. 2)
-SM: SURFACE MOUNT (SEE FIG 3, SHT. 3)

ROW SPECIFICATION
-D: DOUBLE

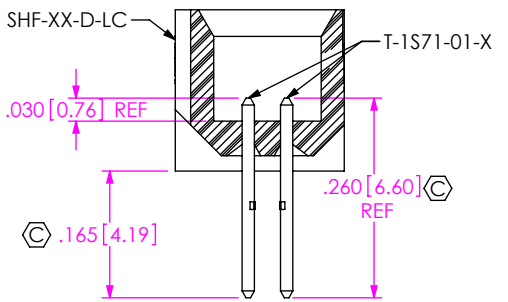
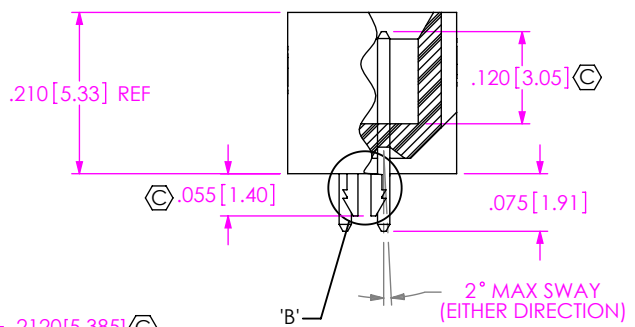
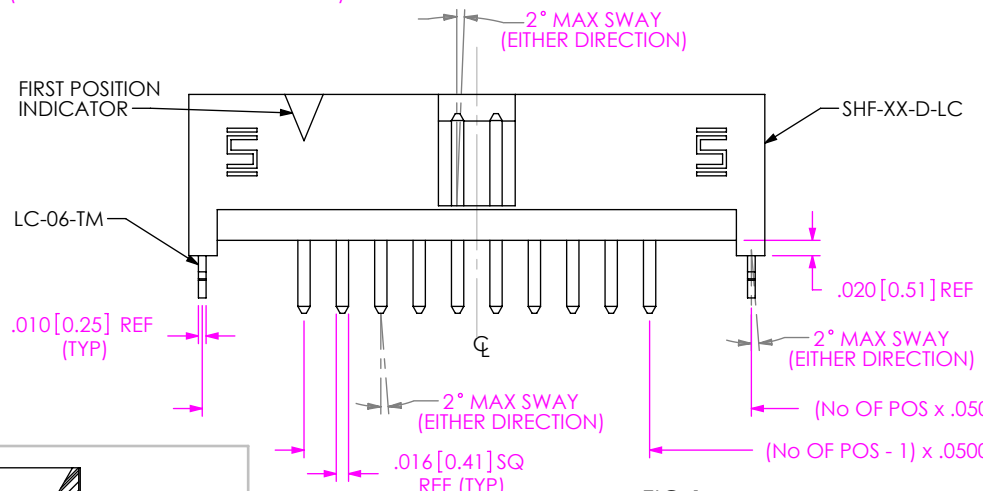
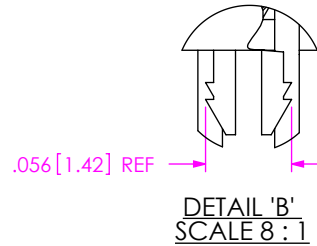
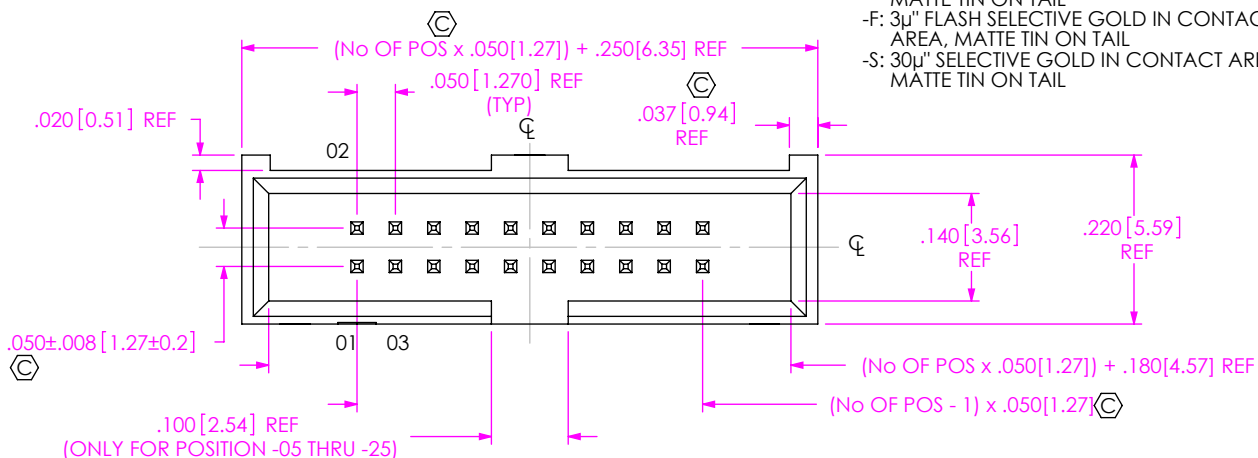

FIG 1 (SHF-110-01-X-D-TH-LC SHOWN)

F:\DWG\MISC\MKTG\SHF-1XX-01-X-D-XX-XX-XX-MKT.SLDDRW

UNLESS OTHERWISE SPECIFIED, DIMENSIONS ARE IN INCHES.
TOLERANCES ARE:
DECIMALS ANGLES
.XX: ±.01 [0.3] 2°
.XXX: ±.005 [0.13]
.XXXX: ±.0020 [0.051]

PROPRIETARY NOTE
THIS DOCUMENT CONTAINS CONFIDENTIAL AND PROPRIETARY INFORMATION AND ALL DESIGN, MANUFACTURING, REPRODUCTION, USE, PATENT RIGHTS AND SALES RIGHTS ARE EXPRESSLY RESERVED BY SAMTEC, INC. THIS DOCUMENT SHALL NOT BE DISCLOSED, IN WHOLE OR PART, TO ANY UNAUTHORIZED PERSON OR ENTITY NOR REPRODUCED, TRANSFERRED OR INCORPORATED IN ANY OTHER PROJECT IN ANY MANNER WITHOUT THE EXPRESS WRITTEN CONSENT OF SAMTEC, INC.



520 PARK EAST BLVD. NEW ALBANY, IN 47150
PHONE: 812-944-6733 FAX: 812-948-5047
e-Mail info@SAMTEC.com code 55322

MATERIAL: DO NOT SCALE DRAWING SHEET SCALE: 4:1
INSULATOR: SUMIKA E6810LHF, UL 94 VO, COLOR: BLACK
TERMINAL: PHOS BRONZE

DESCRIPTION:
.050 x .050 SHROUDED TERMINAL STRIP
DWG. NO.
SHF-1XX-01-X-D-XX-XX-XX
BY: T NEWTON 1/10/2008 SHEET 1 OF 4

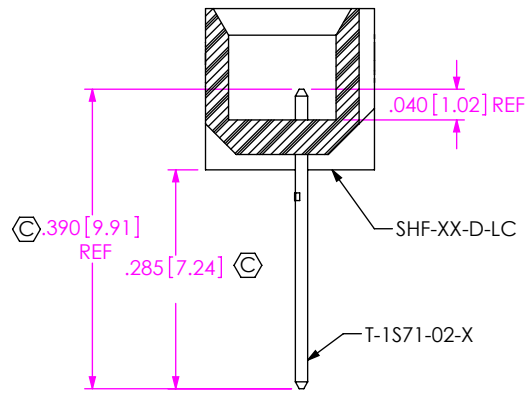

IN-PROCESS 1
(FOR -RA ONLY)

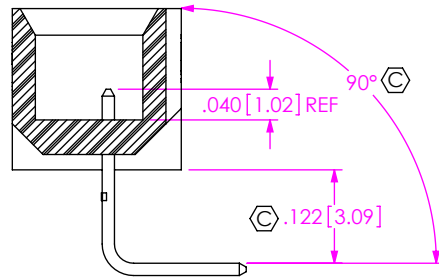

IN-PROCESS 2
(FOR -RA ONLY)

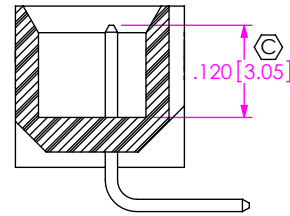

IN-PROCESS 3
(FOR -RA ONLY)

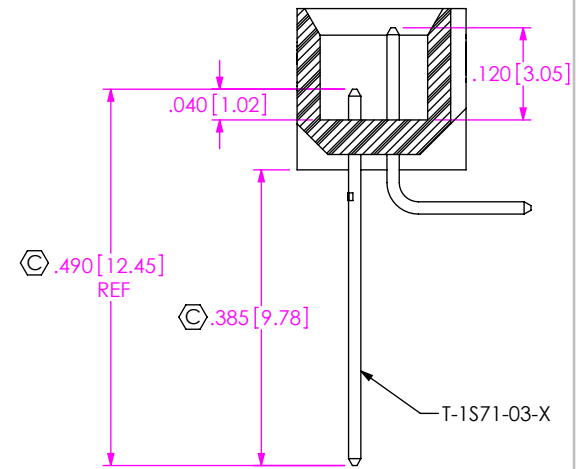

IN-PROCESS 4
(FOR -RA ONLY)

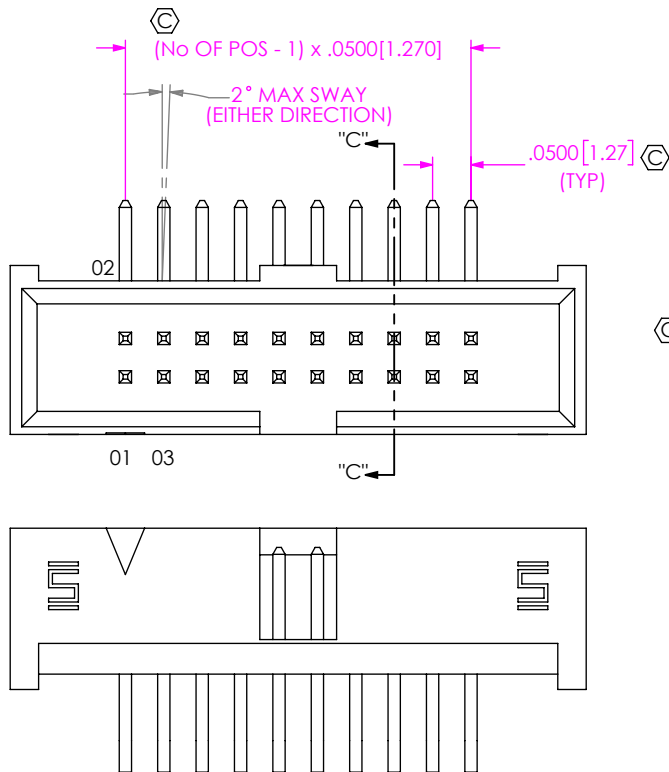
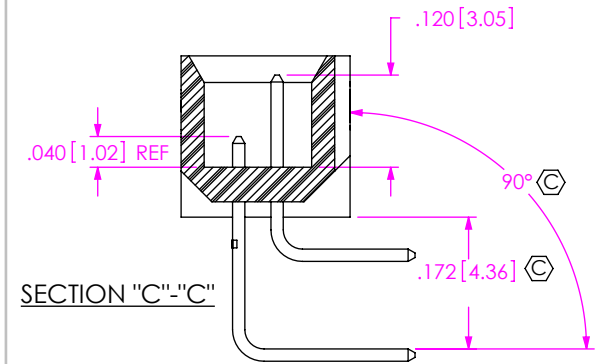
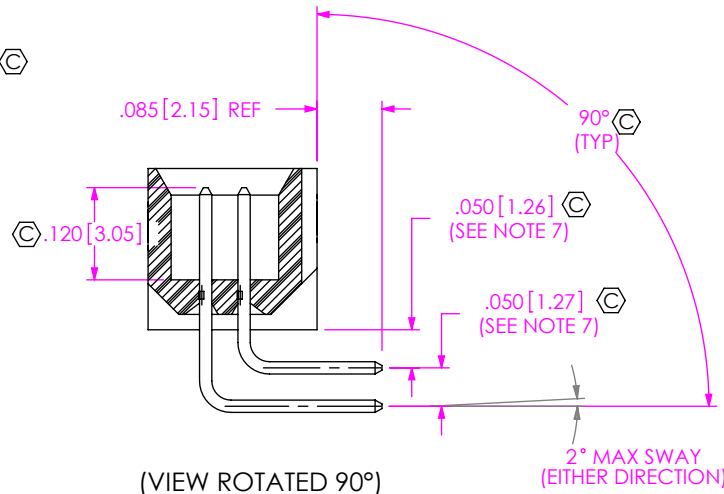

FIG 2
(SHF-110-01-X-D-RA SHOWN)
(SAME AS FIG 1, DIFFERENT AS SHOWN)



IN-PROCESS 5
(FOR -RA ONLY)

F:\DWG\MISC\MKTG\SHF-1XX-01-X-D-XX-XX-XX-MKT.SLDDRW

PROPRIETARY NOTE
THIS DOCUMENT CONTAINS CONFIDENTIAL AND PROPRIETARY INFORMATION AND ALL DESIGN, MANUFACTURING, REPRODUCTION, USE, PATENT RIGHTS AND SALES RIGHTS ARE EXPRESSLY RESERVED BY SAMTEC, INC. THIS DOCUMENT SHALL NOT BE DISCLOSED, IN WHOLE OR PART, TO ANY UNAUTHORIZED PERSON OR ENTITY NOR REPRODUCED, TRANSFERRED OR INCORPORATED IN ANY OTHER PROJECT IN ANY MANNER WITHOUT THE EXPRESS WRITTEN CONSENT OF SAMTEC, INC.

DO NOT SCALE DRAWING

SHEET SCALE: 4:1



520 PARK EAST BLVD, NEW ALBANY, IN 47150
PHONE: 812-944-6733 FAX: 812-948-5047
e-Mail info@SAMTEC.com code 55322

DESCRIPTION:
.050 x .050 SHROUDED TERMINAL STRIP

DWG. NO.
SHF-1XX-01-X-D-XX-XX-XX

BY: T NEWTON 1/10/2008 SHEET 2 OF 4

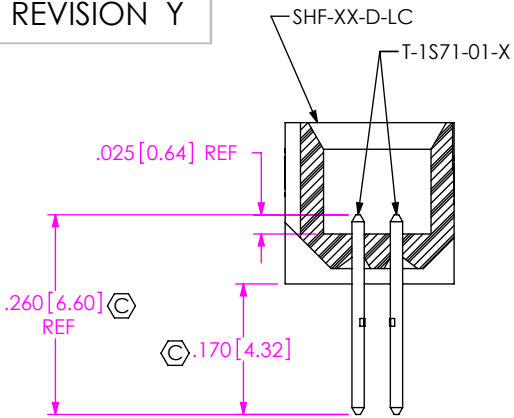

IN-PROCESS 1
(FOR -SM ONLY)

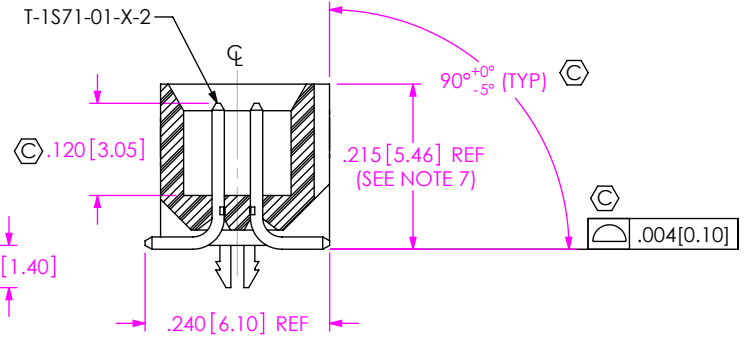
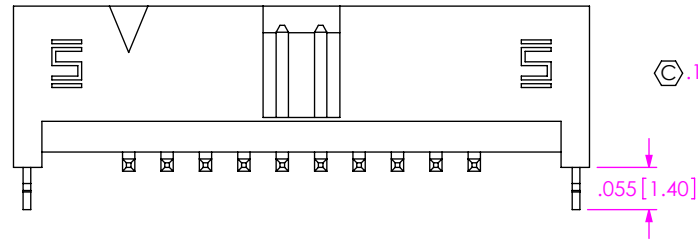
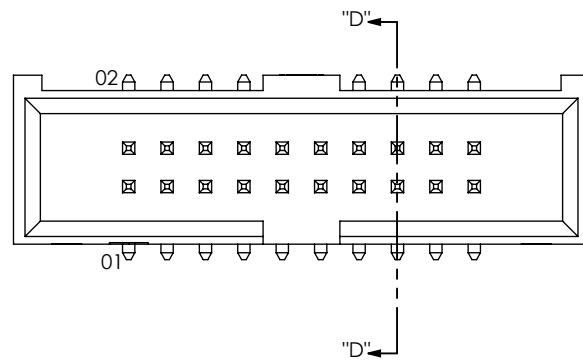

(VIEW ROTATED 90°)

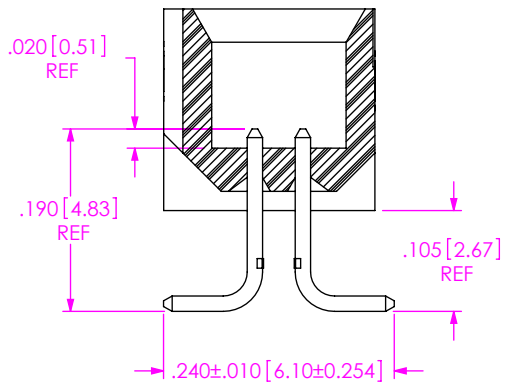

IN-PROCESS 2
(FOR -SM ONLY)

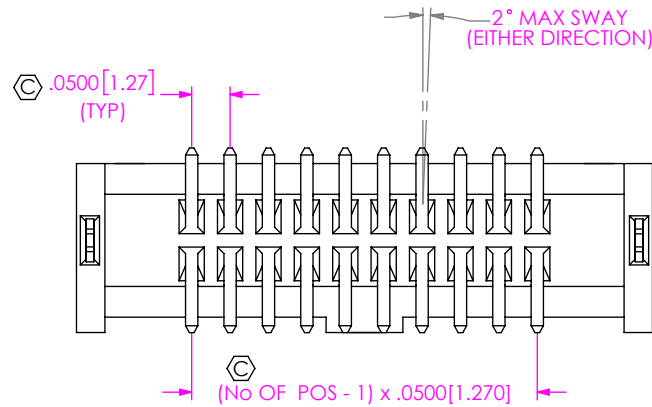

FIG 3
(SHF-110-01-X-D-SM-LC SHOWN)
(SAME AS FIG 1, DIFFERENT AS SHOWN)

F:\DWG\MISC\MKTG\SHF-1XX-01-X-D-XX-XX-MKT.SLDDRW

PROPRIETARY NOTE
THIS DOCUMENT CONTAINS CONFIDENTIAL AND PROPRIETARY INFORMATION AND ALL DESIGN, MANUFACTURING, REPRODUCTION, USE, PATENT RIGHTS AND SALES RIGHTS ARE EXPRESSLY RESERVED BY SAMTEC, INC. THIS DOCUMENT SHALL NOT BE DISCLOSED, IN WHOLE OR PART, TO ANY UNAUTHORIZED PERSON OR ENTITY NOR REPRODUCED, TRANSFERRED OR INCORPORATED IN ANY OTHER PROJECT IN ANY MANNER WITHOUT THE EXPRESS WRITTEN CONSENT OF SAMTEC, INC.

DO NOT SCALE DRAWING

SHEET SCALE: 4:1



520 PARK EAST BLVD, NEW ALBANY, IN 47150
PHONE: 812-944-6733 FAX: 812-948-5047
e-Mail info@SAMTEC.com code 55322

DESCRIPTION:
.050 x .050 SHROUDED TERMINAL STRIP

DWG. NO.
SHF-1XX-01-X-D-XX-XX-XX

BY: T NEWTON 1/10/2008 SHEET 3 OF 4

∅ .256 [6.50] REF

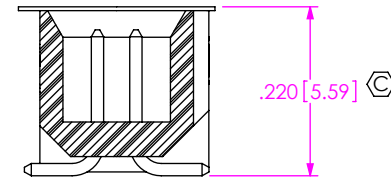
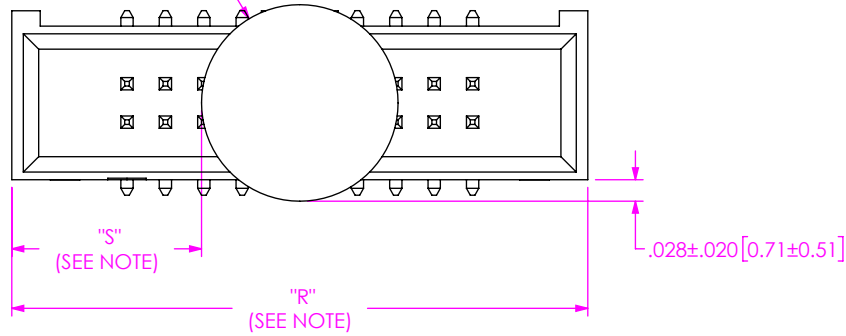

(VIEW ROTATED 90°)

NOTE: "R" = USED MEASURED DIMENSION (REF)
 "S" = $\{("R" - .256[6.50])/2\} \pm 0.020[0.51]$

FIG 4
 (SHF-110-01-X-D-SM-K SHOWN)
 (SAME AS FIG 1, DIFFERENT AS SHOWN)

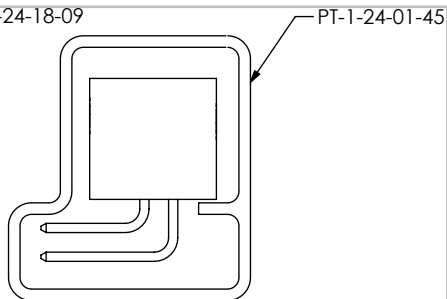
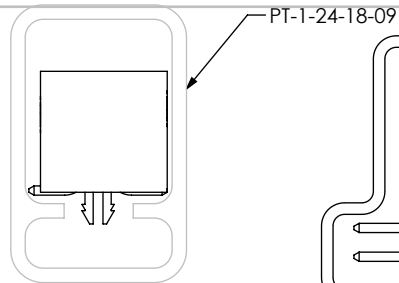
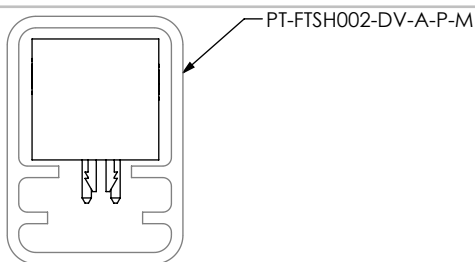

TUBE PACKAGING VIEW
 ALL PARTS ARE LOADED WITH POSITION 1
 TOWARD THE ARROW "EXCEPT -RA"

TABLE 1		
OPTIONS	PACKAGING TUBE	PLUG
-TH, -TH-LC	PT-FTSH002-DV-A-P-M	TP-03
-SM-LC	PT-1-24-18-09	TP-03
-RA	PT-1-24-01-45	TP-07
-SM	PT-1-24-18-09	TP-03

NOTE: ALL POSITIONS ARE TO BE TUBED

CRITICAL DIMENSION INSPECTION INSTRUCTION TABLE	
ASSEMBLY OPERATION	IN-PROCESS INSPECTION
(-TH) FILL T-1S71-01-X	C3, C6, C7, C8, C30, C31
(-TH) REPRESS T-1S71-01-X	C11
(-RA) FILL T-1S71-02-X	C3, C7, C8, C12, C13
(-RA) RA T-1S71-02-X	C32, C33,
(-RA) REPRESS T-1S71-02-X	C34
(-RA) FILL T-1S71-03-X	C6, C7, C14, C15
(-RA) RA T-1S71-03-X	C35, C36
(-RA) REPRESS T-1S71-03-X	C16, C17, C18, C19, C20, C37
(-SM) FILL T-1S71-01-X	C3, C6, C7, C21, C22
(-SM) REPRESS T-1S71-01-X	C23, C24, C26, C38
INSTALL KAPTON	C27, C28
INSTALL LC-06-TM	C9, C29
GPC'S INTENTIONALLY DELETED: C4, C5	

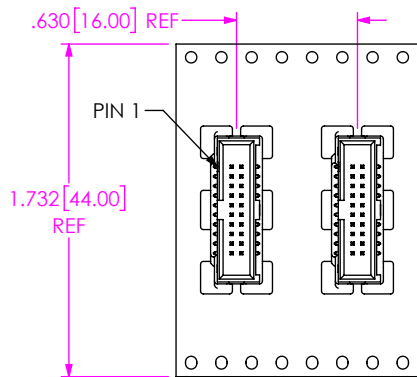

TAPE & REEL PACKAGING VIEW

USER DIRECTION OF UN-REELING
 POCKET NOT DETAILED

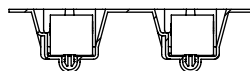

PROPRIETARY NOTE
 THIS DOCUMENT CONTAINS CONFIDENTIAL AND PROPRIETARY INFORMATION AND ALL DESIGN, MANUFACTURING, REPRODUCTION, USE, PATENT RIGHTS AND SALES RIGHTS ARE EXPRESSLY RESERVED BY SAMTEC, INC. THIS DOCUMENT SHALL NOT BE DISCLOSED, IN WHOLE OR PART, TO ANY UNAUTHORIZED PERSON OR ENTITY NOR REPRODUCED, TRANSFERRED OR INCORPORATED IN ANY OTHER PROJECT IN ANY MANNER WITHOUT THE EXPRESS WRITTEN CONSENT OF SAMTEC, INC.

DO NOT SCALE DRAWING

SHEET SCALE: 4:1



520 PARK EAST BLVD, NEW ALBANY, IN 47150
 PHONE: 812-944-6733 FAX: 812-948-5047
 e-Mail info@SAMTEC.com code 55322

DESCRIPTION:
 .050 x .050 SHROUDED TERMINAL STRIP

DWG. NO.
SHF-1XX-01-X-D-XX-XX-XX

BY: T NEWTON 1/10/2008 SHEET 4 OF 4