

**NOT RECOMMENDED FOR NEW DESIGN**  
USE [PAM8902H](#)

**PAM8902**

**30-V<sub>PP</sub> MONO CLASS-D AUDIO AMPLIFIER FOR PIEZO/CERAMIC SPEAKERS**

## Description

The PAM8902 is a mono, Class-D audio amplifier with integrated boost converter designed for piezo and ceramic speakers. The PAM8902 is capable of driving a ceramic/piezo speaker with 30V<sub>PP</sub>(10.6Vrms) from a 3.6V power supply. The PAM8902's Boost converter operates at a fixed frequency of 1.5MHz, and provides a 17.5V supply with a minimum number of external components. PAM8902 features an integrated audio low pass filter that rejects high frequency noise thus improving audio fidelity. And three gain modes of 18dB, 22dB and 26dB for ease of use. PAM8902 also provides thermal, short, under- and over-voltage protection.

The PAM8902 is available in a 16-ball 1.95mm x 1.95mm CSP package and 16-pin QFN4x4 package.

## Features

- Supply Voltage Range From 2.5V to 5.5V
- 30 V<sub>PP</sub> Output Load Voltage From a 2.5V Supply
- Integrated Boost Converter Generates 17.5V Supply
- Programmable Soft-Start
- Small Boost Converter Inductor
- Selectable Gain of 18dB, 22dB, and 26dB
- Selectable Boost Output Voltage of 8V, 12V and 17.5V
- Low Shutdown Current: < 1μA
- Built-in Thermal, OCP, OVP, Short Protection
- Available in Space Saving Packages:
  - 16-ball 1.95mmx1.95mm CSP Package
  - 16-pin QFN4x4 Package

## Applications

- Wireless or Cellular Handsets
- Portable DVD Player
- Personal Digital Assistants (PDAs )
- Electronic Dictionaries
- Digital Still Cameras

## Pin Assignments

16 Ball CSP  
Top View

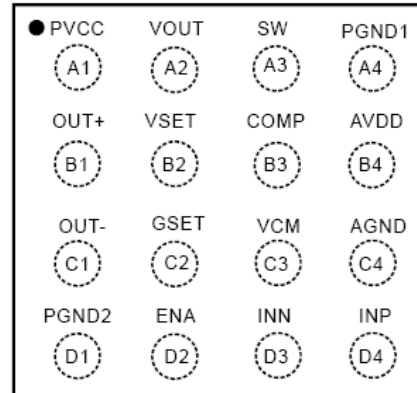

Top View  
QFN 4X4 16L

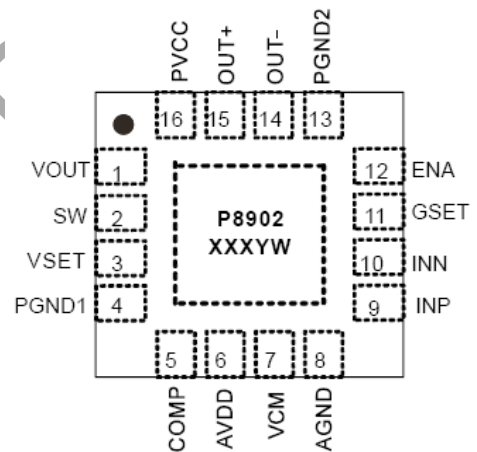

● : Pin 1 Indicator

NOT RECOMMENDED FOR NEW DESIGN

## Typical Applications Circuit

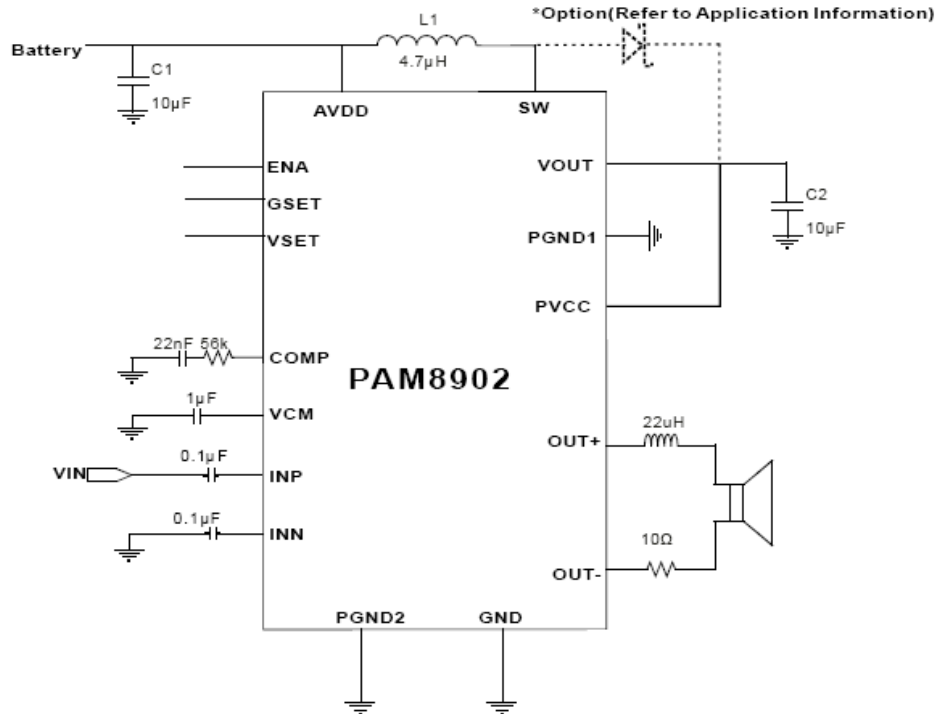

## Pin Descriptions

Pin Name	Bump (CSP)	Pin Number QFN4x4	Function
PVCC	A1	16	Audio Amplifier Power Supply
VOUT	A2	1	Boost Converter Output
SW	A3	2	Boost Converter Switching Node
PGND1	A4	4	Boost Converter Power Ground
OUT+	B1	15	Positive Differential Audio Output
VSET	B2	3	Boost Converter Output Voltage Setting(8V,12V,17.5V)
COMP	B3	5	Boost Converter Compensation
AVDD	B4	6	Power Supply
OUT-	C1	14	Negative Differential Audio Output
GSET	C2	11	Amplifier Gain Setting ( 18dB , 22dB , 26dB)
VCM	C3	7	Common Mode Bypass Cap
AGND	C4	8	Analog Ground
PGND2	D1	13	ClassD Power Ground
ENA	D2	12	Whole Chip Enable
INN	D3	10	Negative Differential Audio Input
INP	D4	9	Positive Differential Audio Input

**Functional Block Diagram**

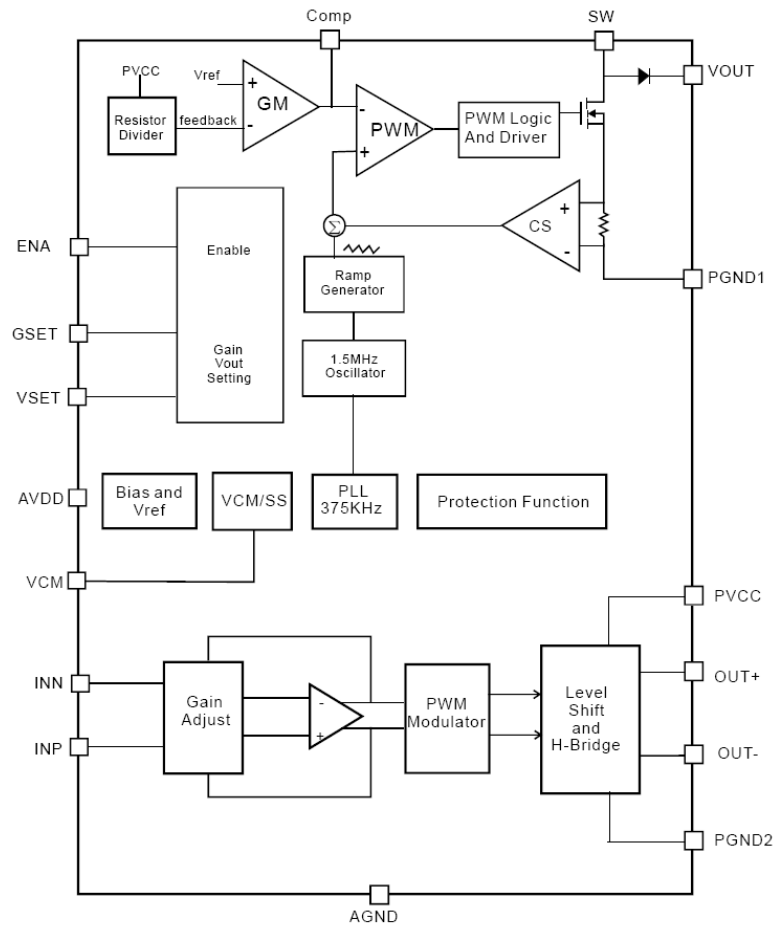

**Absolute Maximum Ratings** (@T<sub>A</sub> = +25°C, unless otherwise specified.)

These are stress ratings only and functional operation is not implied. Exposure to absolute maximum ratings for prolonged time periods may affect device reliability. All voltages are with respect to ground.

Parameter	Rating	Unit
Supply Voltage	6.0	V
Input Voltage	-0.3 to V <sub>DD</sub> +0.3	
Maximum Junction Temperature	+150	°C
Storage Temperature	-65 to +150	
Soldering Temperature	350, 10sec	

**Recommended Operating Conditions** (@T<sub>A</sub> = +25°C, unless otherwise specified.)

Parameter	Rating	Unit
Supply Voltage Range	2.5 to 5.5	V
Ambient Temperature Range	-40 to +85	°C
Junction Temperature Range	-40 to +125	°C

## Thermal Information

Parameter	Package	Symbol	Max	Unit
Thermal Resistance (Junction to Ambient)	CSP	$\theta_{JA}$	90	°C/W
	QFN4x4-16		52	
Thermal Resistance (Junction to Case)	CSP	$\theta_{JC}$	75	
	QFN4x4-16		30	

## Electrical Characteristics (@ $T_A = +25^\circ\text{C}$ , $V_{DD} = 3.6\text{V}$ , $C_L = 1\mu\text{F}$ , $V_{SET}$ Float, unless otherwise specified.)

Parameter	Symbol	Test Conditions	Min	Typ	Max	Units
Input Voltage	$V_{DD}$		2.5		5.5	V
Quiescent Current	$I_Q$	EN > 1.2V, $V_{SET} = \text{High}$		30	48	mA
		EN > 1.2V, $V_{SET} = \text{Floating}$		10	18	
		EN > 1.2V, $V_{SET} = \text{GND}$		5	12	
Shutdown Current	$I_{SD}$	EN = 0V		0.1	1	$\mu\text{A}$
Wake-Up Time	$T_{WU}$	EN from Low to High		40		mS
Chip Enable	$V_{EH}$		1.2			V
Chip Disable	$V_{EL}$				0.4	
GSET/ VSET High	$V_H$		$V_{DD} - 0.5$		$V_{DD}$	V
GSET/ VSET Floating	$V_F$		1		$V_{DD} - 1$	
GSET/ VSET Low	$V_L$		0		0.5	
Under Voltage Lockout Threshold	UVLO	$V_{DD}$ from High to Low		2.2		V
Under Voltage Lockout Hysteresis	UVLO(H)	$V_{DD}$ from Low to High		0.2		
Thermal Shutdown Threshold	OTP			150		°C
Thermal Shutdown Lockout Hysteresis	OTP(H)			30		°C
<b>Boost Converter</b>						
Output Voltage	$V_{O1}$	$V_{SET} = \text{GND}$ , No Load	7.2	8	8.8	V
	$V_{O2}$	$V_{SET} = \text{NC}$ , No Load	10.8	12	13.2	V
	$V_{O3}$	$V_{SET} = \text{AVDD}$ , No Load	16	17.5	19	V
Current Limit	$C_L$	Average Input Current		0.8		A
Lowside MOSFET $R_{DS(ON)}$	$R_{LS}$	$I_O = 50\text{mA}$		0.5		$\Omega$
Boost Switching Frequency	$f_{OSCB}$		1.1	1.5	1.9	MHz
<b>Class D</b>						
Class D Amplifier Switching Frequency	$f_{OSCD}$	Input AC-GND	225	375	475	KHz
Common Mode Reject Ratio	CMRR	$V_{IN} = + -100\text{mV}$ , $V_{DD} = 3.6\text{V}$		60		dB
Output Offset Voltage	$V_{OS}$	Output Offset Voltage		5	50	mV
$R_{DS(ON)}$	RP	High Side		1.5		$\Omega$
		Low Side		0.6		$\Omega$
Closed-Loop Voltage Gain	$A_{V1}$	$G_{SET} = \text{AVDD}$ , $V_O = 1V_{RMS}$	25	26	27	
	$A_{V2}$	$G_{SET} = \text{NC}$ , $V_O = 1V_{RMS}$	21	22	23	
	$A_{V3}$	$G_{SET} = \text{GND}$ , $V_O = 1V_{RMS}$	17	18	19	
Power Supply Reject Ratio	PSRR	200m $V_{PP}$ Supply Ripple @ 217Hz		70		dB
Total Harmonic Distortion Plus Noise	THD+N	$V_O = 5V_{RMS}$		0.3		%
Signal to Noise Ratio	SNR	Input AC Ground, A-Weighting		90		dB

**Typical Performance Characteristics**

(@T<sub>A</sub> = +25°C, V<sub>DD</sub> = 4.2V, Gain = 26dB, C<sub>IN</sub> = 1μF, C<sub>LOAD</sub> = 1μF, unless otherwise specified.)

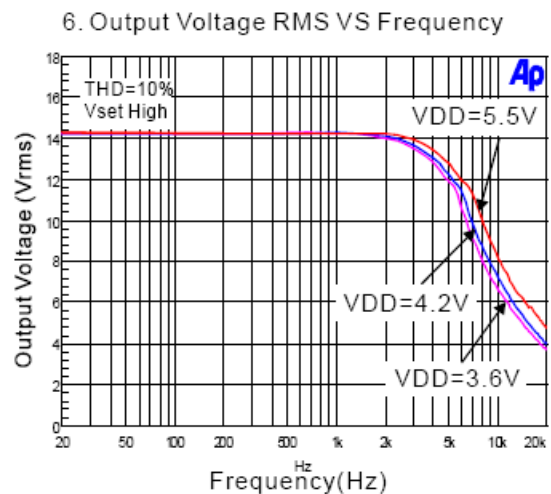
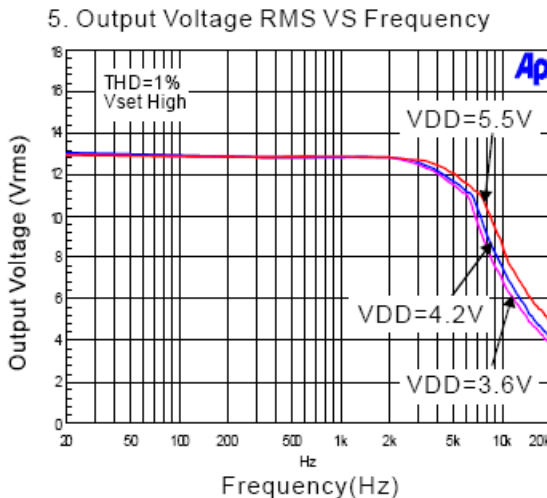
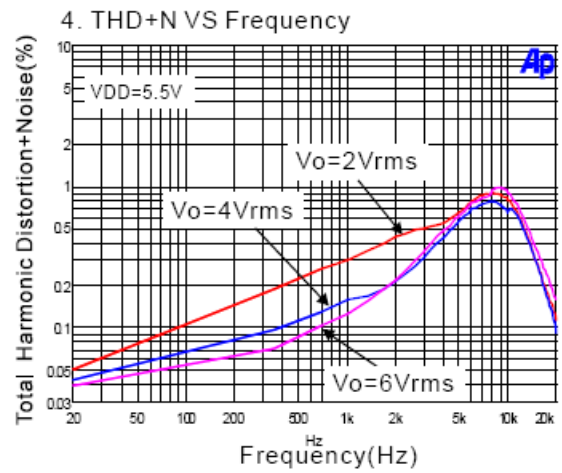
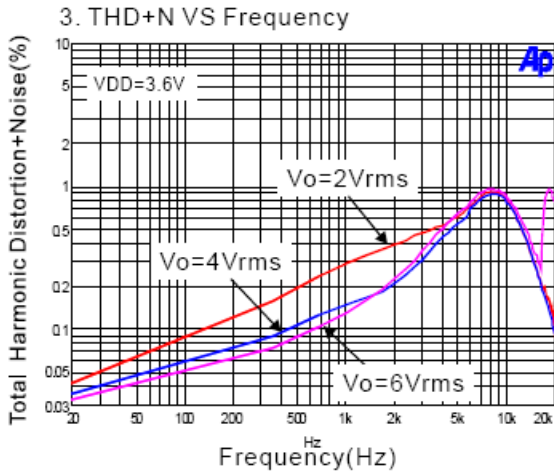
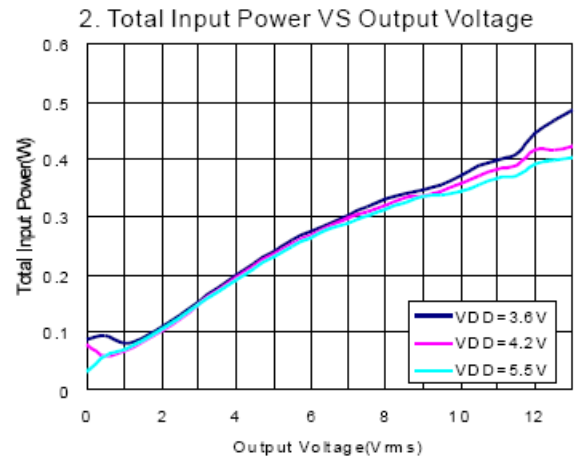
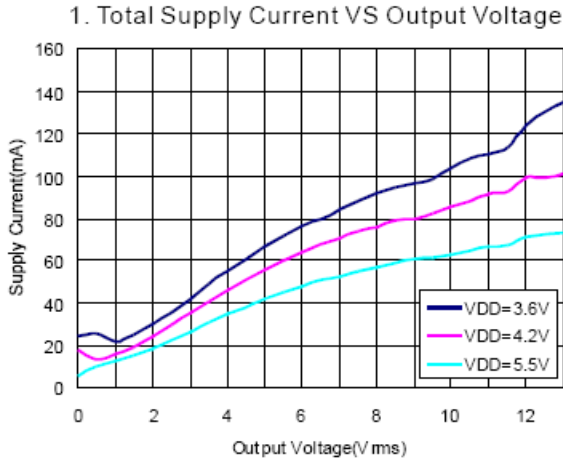

**Typical Performance Characteristics** (cont.) (@ $T_A = +25^\circ\text{C}$ ,  $V_{DD} = 5\text{V}$ , Gain = 18dB, unless otherwise specified.)

7. Output Voltage RMS VS Frequency

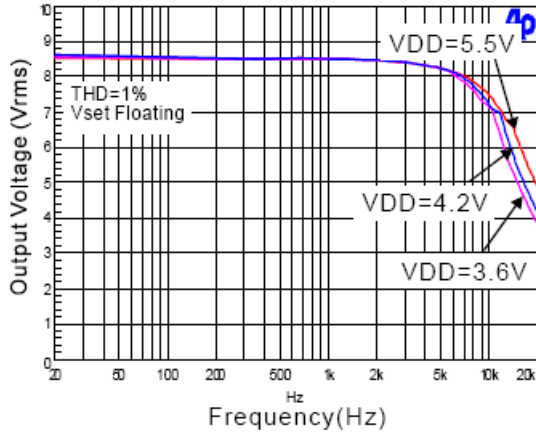

8. Output Voltage RMS VS Frequency

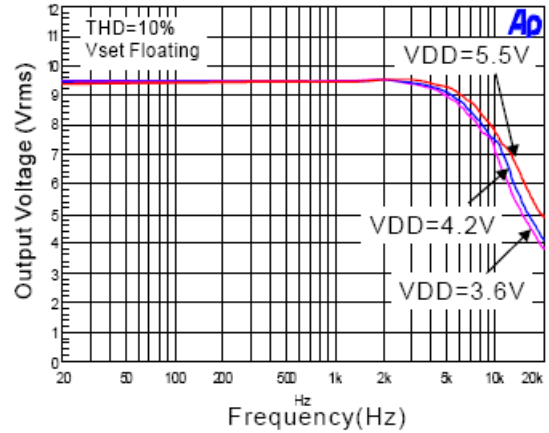

9. Output Voltage RMS VS Frequency

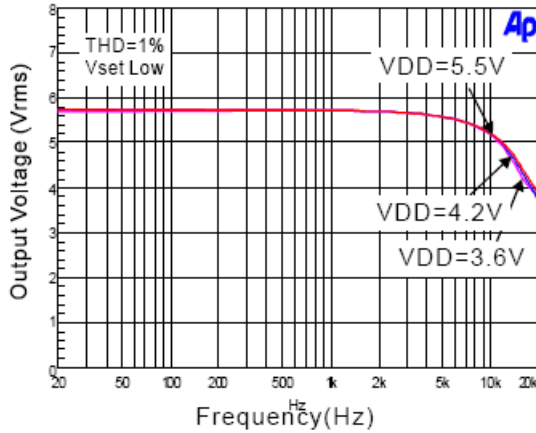

10. Output Voltage RMS VS Frequency

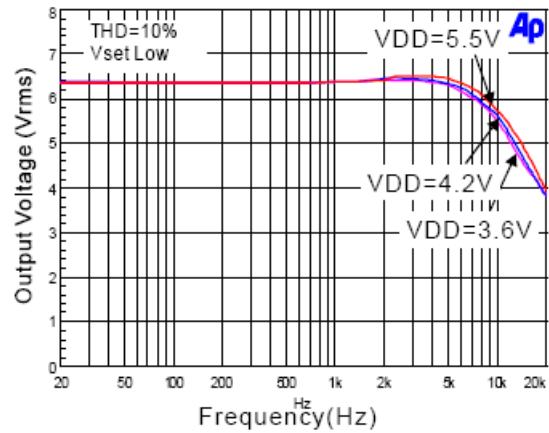

11. Output Voltage RMS VS THD+N

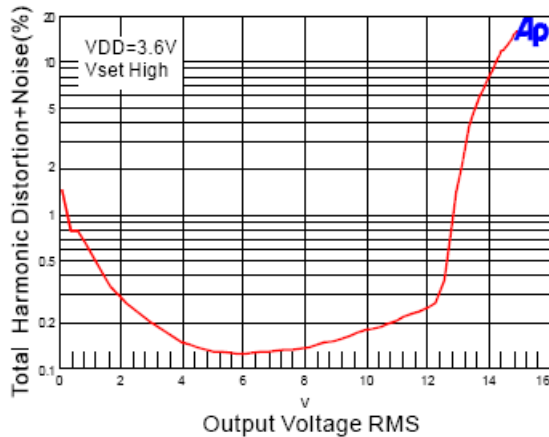

12. Output Voltage RMS VS THD+N

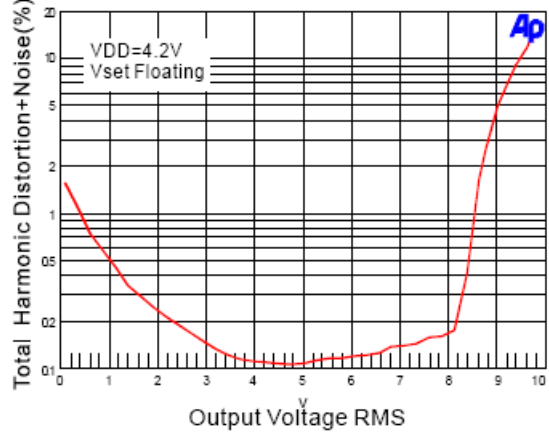

## Application Information

### Select Boost Converter Output Voltage

Customer can use V<sub>SET</sub> pin to set boost converter output voltage between 8V, 12V and 17.5V. V<sub>SET</sub> pin configuration table as below:

V <sub>SET</sub> Pin Configuration	Min	Max	PVCC Voltage	Audio Amplifier Maximum Output Voltage
Connect to AVDD	AVDD – 0.5	AVDD	17.5V	11 V <sub>RMS</sub> (V <sub>PP</sub> = 31.1V)
Floating	1V	AVDD – 1V	12V	8 V <sub>RMS</sub> (V <sub>PP</sub> = 22.6V)
Connect to GND	GND	0.5V	8V	5 V <sub>RMS</sub> (V <sub>PP</sub> = 14.1V)

### Input Resistance (R<sub>i</sub>)

The input resistors (R<sub>i</sub> = R<sub>IN</sub> + R<sub>EX</sub>) set the gain of the amplifier according to Equation 1 when anti-saturation is inactive.

$$G = 20 \text{ Log} [12.8 * R_F / (R_{IN} + R_{EX})] \text{ (dB)}$$

G <sub>SET</sub>	R <sub>IN</sub>	R <sub>FB</sub>
G <sub>SET</sub> = V <sub>DD</sub>	77.4kΩ	122.6kΩ
G <sub>SET</sub> = Floating	100kΩ	100kΩ
G <sub>SET</sub> = GND	122.6kΩ	77.4kΩ

Where R<sub>IN</sub> is a 77.4kΩ internal resistor, R<sub>EX</sub> is the external input resistor, R<sub>F</sub> is a 122.6kΩ internal resistor. Resistor matching is very important in fully differential amplifiers. The balance of the output on the reference voltage depends on matched ratios of the resistors. CMRR, PSRR, and cancellation of the second harmonic distortion diminish if resistor mismatch occurs. Therefore, it is recommended to use 1% tolerance resistors or better to keep the performance optimized. Matching is more important than overall tolerance. Resistor arrays with 1% matching can be used with a tolerance greater than 1%. Place the input resistors very close to the PAM8902 to limit noise injection on the high-impedance nodes. For optimal performance the gain should be set to lower. Lower gain allows the PAM8902 to operate at its best, and keeps a high voltage at the input making the inputs less susceptible to noise. In addition to these features, higher value of R<sub>i</sub> minimizes pop noise.

### Input Capacitors (C<sub>i</sub>)

In the typical application, an input capacitor, C<sub>i</sub>, is required to allow the amplifier to bias the input signal to the proper DC level for optimum operation. In this case, C<sub>i</sub> and the minimum input impedance R<sub>i</sub> form a high-pass filter with the corner frequency determined in the following equation:

$$F_C = \frac{1}{2\pi R_i C_i}$$

It is important to consider the value of C<sub>i</sub> as it directly affects the low frequency performance of the circuit.

For example, when R<sub>i</sub> is 150k and the specification calls for a flat bass response are down to 150Hz.

Equation is reconfigured as followed:

$$C_i = \frac{1}{2\pi R_i F_C}$$

When input resistance variation is considered, the C<sub>i</sub> is 7nF, so one would likely choose a value of 10nF. A further consideration for this capacitor is the leakage path from the input source through the input network (C<sub>i</sub>, R<sub>i</sub> + R<sub>F</sub>) to the load. This leakage current creates a DC offset voltage at the input to the amplifier that reduces useful headroom, especially in high gain applications. For this reason, a low-leakage tantalum or ceramic capacitor is the best choice. When polarized capacitors are used, the positive side of the capacitor should face the amplifier input in most applications as the DC level is held at V<sub>DD</sub> / 2, which is likely higher than the source DC level. Please note that it is important to confirm the capacitor polarity in the application.

---

## Application Information

---

### Decoupling Capacitor

The PAM8902 is a high-performance CMOS audio amplifier that requires adequate power supply decoupling to ensure the output total harmonic distortion (THD) as low as possible. The optimum decoupling is achieved by using two different types of capacitors that target on different types of noise on the power supply leads. For higher frequency transients, spikes, or digital hash on the line, a good low equivalent series-resistance (ESR) ceramic capacitor, typically 1 $\mu$ F is placed as close as possible to the device AVDD pin for the best operation. For filtering lower frequency noise signals, a large ceramic capacitor of 10 $\mu$ F or greater placed near the AVDD supply trace is recommended.

### External Schottky Diode

Use external schottky diode can get the best driving capability and efficiency.

Since internal power diode has limited driving capability, only in following conditions customer can remove the external schottky diode to reduce the cost.

1. VSET = GND or Floating and  $C_L$  less than 1 $\mu$ F.
2. The signal frequency less than 4KHz.
3. Haptic application (50-500Hz)

### Shutdown Operation

In order to reduce power consumption while not in use, the PAM8902 contains shutdown circuitry amplifier off when a logic low is placed on the ENA pin. By switching the ENA pin connected to GND, the PAM8902 supply current draw will be minimized in idle mode.

### Under-Voltage Lock-Out (UVLO)

The PAM8902 incorporates circuitry designed to detect supply voltage. When the supply voltage drops to 2.2V or below, the PAM8902 goes into a state of shutdown, and the device comes out of its shutdown state and restore to normal function only when reset the power supply or ENA pin.

### Short-Circuit Protection (SCP)

The PAM8902 has short circuit protection circuitry on the outputs to prevent the device from damage when output-to-output shorted or output-to-GND shorted occurs. When a short circuit occurs, the device goes into a latch state and must be reset by cycling the voltage on the ENA pin to a logic low and then back to the logic high state for normal operation. This will clear the short-circuit flag and allow for normal operation if the short was removed. If the short was not removed, the protection circuitry will again activate.

### Over-Temperature Protection (OTP)

Thermal protection on the PAM8902 prevents the device from damage when the internal die temperature exceeds +150°C. There is a +15°C tolerance on this trip point from device to device. Once the die temperature exceeds the set point, the device will enter the shutdown state and the outputs are disabled in this condition both OUT+ and OUT- will become high impedance. This is not a latched fault. The thermal fault is cleared once the temperature of the die decreased by +30°C. This large hysteresis will prevent motor boating sound well and the device begins normal operation at this point with no external system interaction.



**Ordering Information**

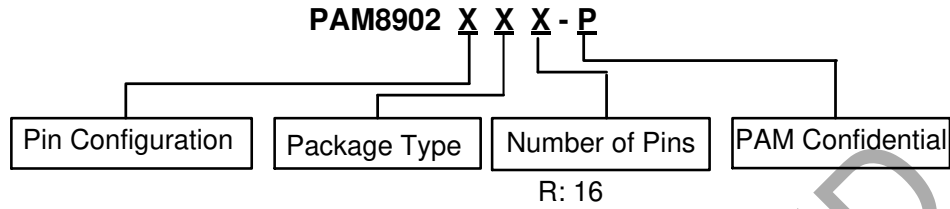

Part Number	Part Marking	Package Type	Standard Package
PAM8902ZER-P	BG YW	CSP-16L	3000Units/Tape&Reel
PAM8902KER-P	P8902 XXXYW	QFN4x4-16L	3000Units/Tape&Reel

**Marking Information**

**Y: Last Digital of Manufacturing Year**

- 6: 2006
- 7: 2007
- 8: 2008
- 9: 2009
- 0: 2010
- 1: 2011

**W: Week Code**

Item	Week Code	Item	Week Code	Item	Week Code	Item	Week Code
1	A	14	N	27	A	40	N
2	B	15	O	28	B	41	O
3	C	16	P	29	C	42	P
4	D	17	Q	30	D	43	Q
5	E	18	R	31	E	44	R
6	F	19	S	32	F	45	S
7	G	20	T	33	G	46	T
8	H	21	U	34	H	47	U
9	I	22	V	35	I	48	V
10	J	23	W	36	J	49	W
11	K	24	X	37	K	50	X
12	L	25	Y	38	L	51	Y
13	M	26	Z	39	M	52	Z

**Marking Information** (cont.)

16 Ball CSP  
Top View

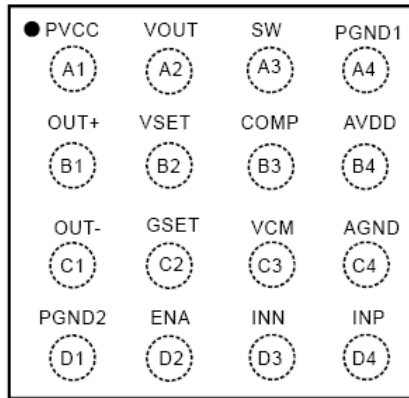

**Marking**

BG  
YW

BG: Product Code of PAM8902  
Y: Year  
W: Week

Top View  
QFN 4X4 16L

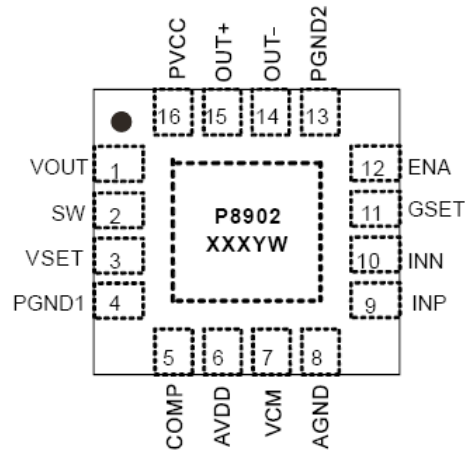

Y: Year  
W: Week  
X: Internal Code

●: Pin 1 Indicator

NOT FOR

**Package Outline Dimensions** (All dimensions in mm.)

CSP-16

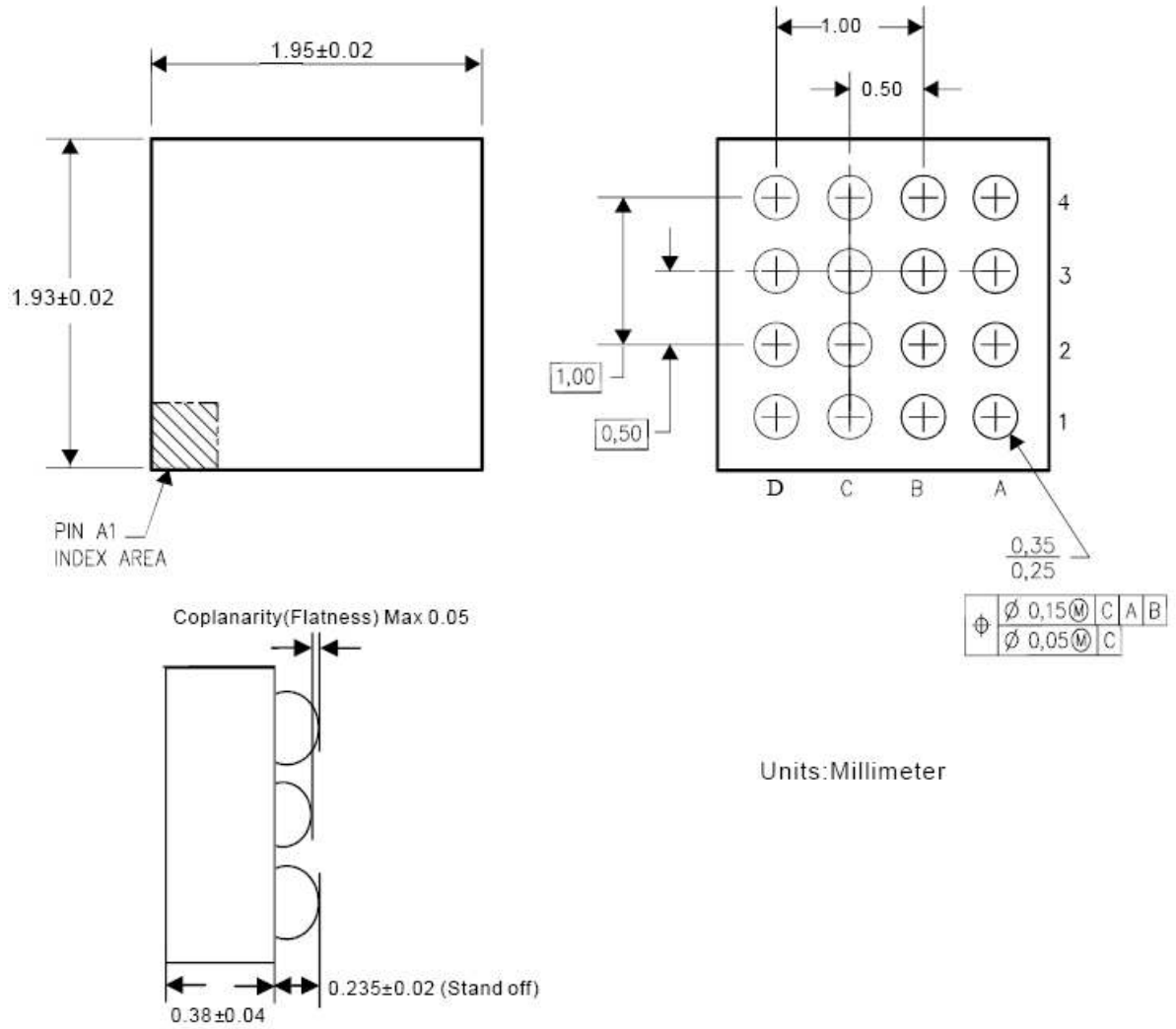

NC FOR

**Package Outline Dimensions** (cont.) (All dimensions in mm.)

QFN4x4-16

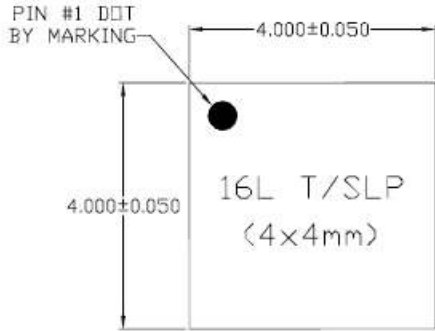

TOP VIEW

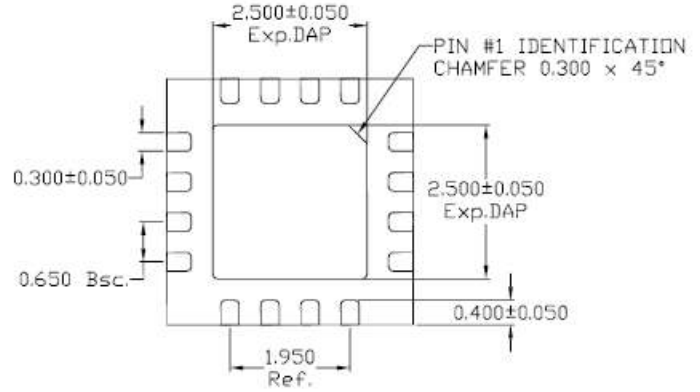

BOTTOM VIEW

NOTE:

1) TSLP AND SLP SHARE THE SAME EXPOSE OUTLINE BUT WITH DIFFERENT THICKNESS:

		TSLP	SLP
A	MAX.	0.800	0.900
	NOM.	0.750	0.850
	MIN.	0.700	0.800

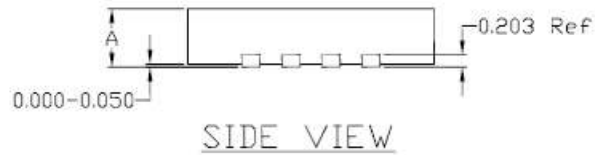

SIDE VIEW

NOT RECOMMENDED FOR NEW DESIGN

**IMPORTANT NOTICE**

DIODES INCORPORATED MAKES NO WARRANTY OF ANY KIND, EXPRESS OR IMPLIED, WITH REGARDS TO THIS DOCUMENT, INCLUDING, BUT NOT LIMITED TO, THE IMPLIED WARRANTIES OF MERCHANTABILITY AND FITNESS FOR A PARTICULAR PURPOSE (AND THEIR EQUIVALENTS UNDER THE LAWS OF ANY JURISDICTION).

Diodes Incorporated and its subsidiaries reserve the right to make modifications, enhancements, improvements, corrections or other changes without further notice to this document and any product described herein. Diodes Incorporated does not assume any liability arising out of the application or use of this document or any product described herein; neither does Diodes Incorporated convey any license under its patent or trademark rights, nor the rights of others. Any Customer or user of this document or products described herein in such applications shall assume all risks of such use and will agree to hold Diodes Incorporated and all the companies whose products are represented on Diodes Incorporated website, harmless against all damages.

Diodes Incorporated does not warrant or accept any liability whatsoever in respect of any products purchased through unauthorized sales channel. Should Customers purchase or use Diodes Incorporated products for any unintended or unauthorized application, Customers shall indemnify and hold Diodes Incorporated and its representatives harmless against all claims, damages, expenses, and attorney fees arising out of, directly or indirectly, any claim of personal injury or death associated with such unintended or unauthorized application.

Products described herein may be covered by one or more United States, international or foreign patents pending. Product names and markings noted herein may also be covered by one or more United States, international or foreign trademarks.

This document is written in English but may be translated into multiple languages for reference. Only the English version of this document is the final and determinative format released by Diodes Incorporated.

**LIFE SUPPORT**

Diodes Incorporated products are specifically not authorized for use as critical components in life support devices or systems without the express written approval of the Chief Executive Officer of Diodes Incorporated. As used herein:

- A. Life support devices or systems are devices or systems which:
1. are intended to implant into the body, or
  2. support or sustain life and whose failure to perform when properly used in accordance with instructions for use provided in the labeling can be reasonably expected to result in significant injury to the user.
- B. A critical component is any component in a life support device or system whose failure to perform can be reasonably expected to cause the failure of the life support device or to affect its safety or effectiveness.

Customers represent that they have all necessary expertise in the safety and regulatory ramifications of their life support devices or systems, and acknowledge and agree that they are solely responsible for all legal, regulatory and safety-related requirements concerning their products and any use of Diodes Incorporated products in such safety-critical, life support devices or systems, notwithstanding any devices- or systems-related information or support that may be provided by Diodes Incorporated. Further, Customers must fully indemnify Diodes Incorporated and its representatives against any damages arising out of the use of Diodes Incorporated products in such safety-critical, life support devices or systems.

Copyright © 2012, Diodes Incorporated

[www.diodes.com](http://www.diodes.com)