

STRAIGHT PLUG CRIMP OR SOLDER TYPE

R125.069.000

CABLE 2/50 S

Series : SMA

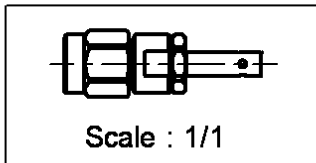
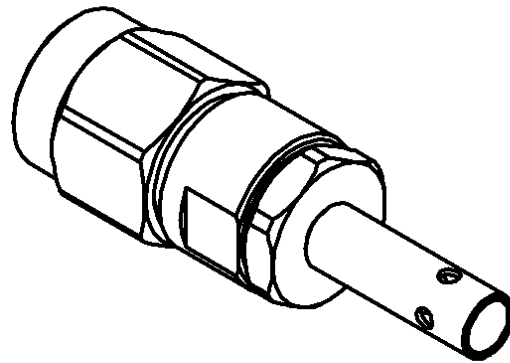
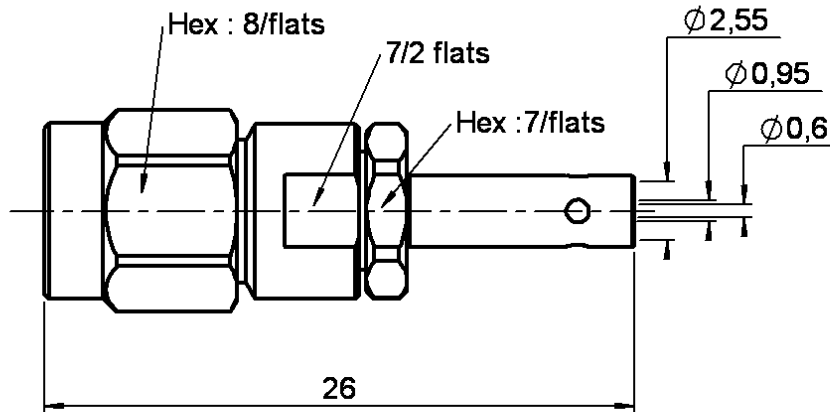

All dimensions are in mm.



COMPONENTS	MATERIALS	PLATINGS (µm)
BODY	STAINLESS STEEL	GOLD 0.5 OVER NICKEL 2
CENTER CONTACT	BRASS	GOLD 1.3 OVER NICKEL 2
OUTER CONTACT	-	-
INSULATOR	PTFE	-
GASKET	SILICONE RUBBER	-
OTHERS PARTS	STAINLESS STEEL	GOLD 0.5 OVER NICKEL 2
-	-	-
-	-	-

Issue : 0210 B

In the effort to improve our products, we reserve the right to make changes judged to be necessary.



STRAIGHT PLUG CRIMP OR SOLDER TYPE

R125.069.000

CABLE 2/50 S

Series : SMA

PACKAGING

Standard	Unit	Other
100	'W' option	Contact us

SPECIFICATION

ELECTRICAL CHARACTERISTICS

Impedance		50 Ω
Frequency		0-12.4 GHz
VSWR	1.20 +	0.025 x F(GHz) Maxi
Insertion loss		0.06 √F(GHz) dB Maxi
RF leakage	- (60 - F(GHz)) dB Maxi
Voltage rating		170 Veff Maxi
Dielectric withstanding voltage		500 Veff mini
Insulation resistance		5000 MΩ mini

CABLE ASSEMBLY

Stripping	a	b	c	d	e	f
mm	3.50	7.00	13.5	0.00	10.0	0.00

Assembly instruction : **Crimp 10**

Recommended cable(s)
 RG 178
 KX 21
 RG 196
 RG 178 LC

Cable retention
 - pull off **45** N mini
 - torque **NA** N.cm

MECHANICAL CHARACTERISTICS

Center contact retention		
Axial force – Mating end	27	N mini
Axial force – Opposite end	27	N mini
Torque	NA	N.cm mini

TOOLING

Part Number	Description	Hexagon
.	.	.
R282.235.003	CRIMPING DIES	2.67
R282.211.000	CRIMPING TOOL	2.67
R282.293.000	CRIMPING TOOL	-

Recommended torque		
Mating	100	N.cm
Panel nut	NA	N.cm
Clamp nut	120	N.cm
A/F clamp nut	7.000	mm

Mating life	500	Cycles mini
Weight	0.000	g

OTHERS CHARACTERISTICS

ENVIRONMENTAL

Operating temperature	-65/+165	° C
Hermetic seal	NA	Atm.cm3/s
Panel leakage	NA	

Issue : 0210 B

In the effort to improve our products, we reserve the right to make changes judged to be necessary.

