

© COPYRIGHT 1981 BY AMP INCORPORATED, HARRISBURG, PA. ALL INTERNATIONAL RIGHTS RESERVED, AMP INCORPORATED PRODUCTS COVERED BY U.S. AND FOREIGN PATENTS AND /OR PATENTS PENDING.

REVISIONS				
LTR	DESCRIPTION	DATE	APPROVED	P/F
0	RELEASED	2-10-81	SD <i>MJ</i>	

1. ALL DIMENSIONS SHOWN ARE FOR REFERENCE ONLY UNLESS OTHERWISE SPECIFIED.

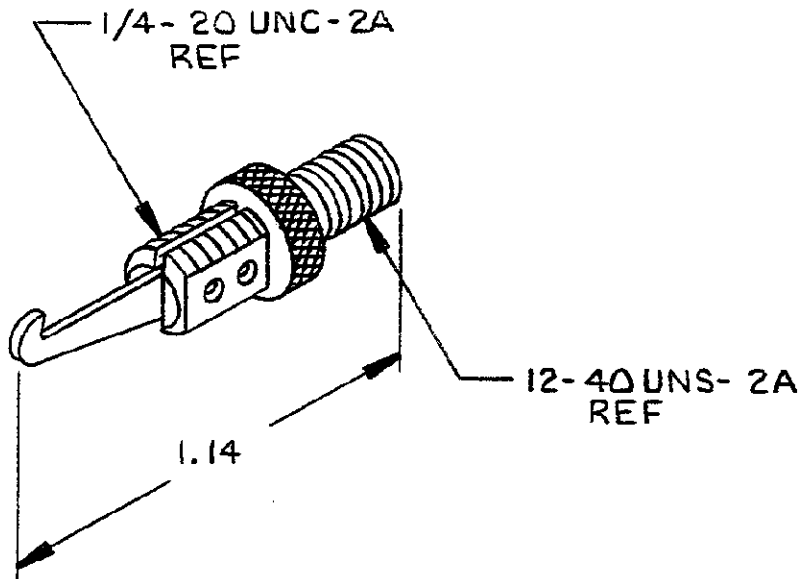

231106-1 AS SHOWN

PART NO

UNLESS OTHERWISE SPECIFIED DIMENSIONS ARE IN INCHES. TOLERANCES ON: DECIMALS ± # ANGLES ± #	CONTRACT NO	 AMP INCORPORATED Harrisburg, Pa.		
	DR <i>Stephen Doss</i> 2-10-81			
MATERIAL	CHK <i>MD Friel</i> 2-12-81	NAME		
APPD <i>A de Bot</i> 2/12/81	APPD <i>C. Coe</i> 2/12/81	ASSEMBLY, HOOK, EXTRACTOR		
FINISH	DSGN APPD	SIZE	CODE IDENT NO	NUMBER
	OTHER APPD	A	00779	231106
		SCALE	SHEET	
		2/1	1 OF 1	