

Important notice

Dear Customer,

On 7 February 2017 the former NXP Standard Product business became a new company with the tradename **Nexperia**. Nexperia is an industry leading supplier of Discrete, Logic and PowerMOS semiconductors with its focus on the automotive, industrial, computing, consumer and wearable application markets

In data sheets and application notes which still contain NXP or Philips Semiconductors references, use the references to Nexperia, as shown below.

Instead of <http://www.nxp.com>, <http://www.philips.com/> or <http://www.semiconductors.philips.com/>, use <http://www.nexperia.com>

Instead of sales.addresses@www.nxp.com or sales.addresses@www.semiconductors.philips.com, use salesaddresses@nexperia.com (email)

Replace the copyright notice at the bottom of each page or elsewhere in the document, depending on the version, as shown below:

- © NXP N.V. (year). All rights reserved or © Koninklijke Philips Electronics N.V. (year). All rights reserved

Should be replaced with:

- © **Nexperia B.V. (year). All rights reserved.**

If you have any questions related to the data sheet, please contact our nearest sales office via e-mail or telephone (details via salesaddresses@nexperia.com). Thank you for your cooperation and understanding,

Kind regards,

Team Nexperia

IP3348CX5; IP3348CX10; IP3348CX15; IP3348CX20

Integrated multi channel LC-filter network for high-speed data interfaces with ESD protection to IEC 61000-4-2 level 4

Rev. 1.1 — 4 April 2011

Product data sheet

1. Product profile

1.1 General description

IP3348CX5, IP3348CX10, IP3348CX15 and IP3348CX20 is a 2, 4, 6 and 8-channel LC low-pass filter network for high-speed data interfaces. It is designed to provide filtering of undesired RF signals in the 800 MHz to 3 GHz frequency band while supporting data rates up to 400 Mbit/s. In addition, IP3348CX5, IP3348CX10, IP3348CX15 and IP3348CX20 incorporates diodes to provide protection to downstream components from ElectroStatic Discharge (ESD) voltages as high as ± 20 kV contact discharge according the IEC 61000-4-2 model, far exceeding standard level 4.

The devices are fabricated using monolithic silicon technology and integrate up to 8 inductors and up to 8 pairs of back-to-back diodes in a 0.4 mm pitch Wafer-Level Chip-Scale Package (WLCSP). These features make the IP3348CX5; IP3348CX10; IP3348CX15; IP3348CX20 ideal for use in applications requiring the utmost in miniaturization such as mobile phone handsets, cordless telephones and other portable electronic devices.

1.2 Features and benefits

- Pb-free, RoHS compliant and free of halogen and antimony (Dark Green compliant)
- Supports data rates up to 400 Mbit/s
- Integrated ESD protection withstanding ± 20 kV contact discharge, far exceeding IEC 61000-4-2 level 4
- WLCSP with 0.4 mm pitch

1.3 Applications

- ElectroMagnetic Interference (EMI) filtering and ESD protection for high-speed data interfaces like Mobile Industry Processor Interface (MIPI) and Mobile Display Digital Interface (MDDI)
- Camera imager interface
- High resolution color Liquid Crystal Display (LCD) interfaces



2. Pinning information

2.1 Pinning

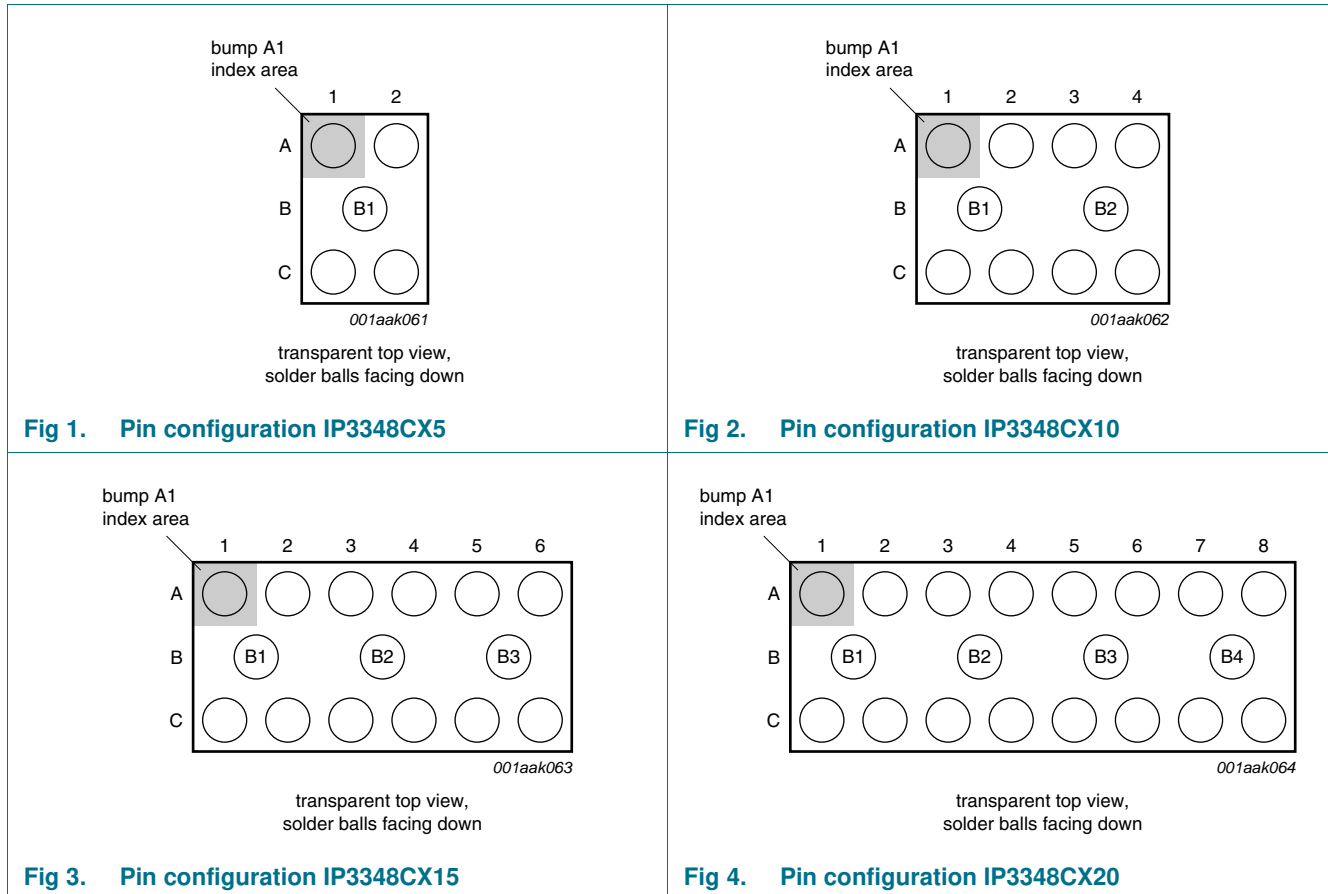

2.2 Pin description

Table 1. Pinning

Pin	IP3348CX5	IP3348CX10	IP3348CX15	IP3348CX20	Description
A1 and C1	A1 and C1	A1 and C1	A1 and C1	A1 and C1	filter channel 1
A2 and C2	A2 and C2	A2 and C2	A2 and C2	A2 and C2	filter channel 2
-	A3 and C3	A3 and C3	A3 and C3	A3 and C3	filter channel 3
-	A4 and C4	A4 and C4	A4 and C4	A4 and C4	filter channel 4
-	-	A5 and C5	A5 and C5	A5 and C5	filter channel 5
-	-	A6 and C6	A6 and C6	A6 and C6	filter channel 6
-	-	-	A7 and C7	A7 and C7	filter channel 7
-	-	-	A8 and C8	A8 and C8	filter channel 8
B1	B1 and B2	B1, B2 and B3	B1, B2, B3 and B4	B1, B2, B3 and B4	ground

3. Ordering information

Table 2. Ordering information

Type number	Package		Version
	Name	Description	
IP3348CX5	WLCSP5	wafer level chip-size package; 5 bumps (2-1-2)	IP3348CX5
IP3348CX10	WLCSP10	wafer level chip-size package; 10 bumps (4-2-4)	IP3348CX10
IP3348CX15	WLCSP15	wafer level chip-size package; 15 bumps (6-3-6)	IP3348CX15
IP3348CX20	WLCSP20	wafer level chip-size package; 20 bumps (8-4-8)	IP3348CX20

4. Functional diagram

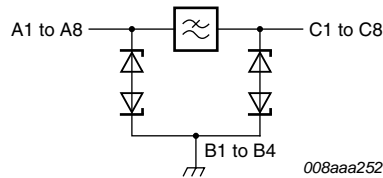

Fig 5. Schematic diagram of IP3348CX5; IP3348CX10; IP3348CX15; IP3348CX20

5. Limiting values

Table 3. Limiting values

In accordance with the Absolute Maximum Rating System (IEC 60134).

Symbol	Parameter	Conditions	Min	Max	Unit
V_I	input voltage		-4	+4	V
I_{ch}	channel current (DC)	$T_{amb} = 85\text{ °C}$	-	20	mA
V_{ESD}	electrostatic discharge voltage	all pins to ground			
		contact discharge; 10 pulses [1]	-20	+20	kV
		air discharge	-20	+20	kV
		IEC 61000-4-2 level 4; all pins to ground			
		contact discharge	-8	+8	kV
	air discharge	-15	+15	kV	
P_{ch}	channel power dissipation	continuous; $T_{amb} = 85\text{ °C}$	-	10	mW
T_{stg}	storage temperature		-55	+150	°C
$T_{reflow(peak)}$	peak reflow temperature	10 s maximum	-	260	°C
T_{amb}	ambient temperature		-40	+85	°C

[1] Device is qualified with 1000 pulses of $\pm 15\text{ kV}$ contact discharges each, according to the IEC 61000-4-2 model and far exceeds the specified level 4 (8 kV contact discharge).

6. Characteristics

Table 4. Channel characteristics

$T_{amb} = 25\text{ }^{\circ}\text{C}$; unless otherwise specified.

Symbol	Parameter	Conditions	Min	Typ	Max	Unit
$R_{s(ch)}$	channel series resistance		-	10	-	Ω
$L_{s(ch)}$	channel series inductance		[1]	15	-	nH
C_{ch}	channel capacitance	$f = 100\text{ kHz}$	[1]			
		$V_{bias(DC)} = 0\text{ V}$	-	30	-	pF
		$V_{bias(DC)} = 2.5\text{ V}$	-	25	-	pF
V_{BR}	breakdown voltage	$I_{test} = 1\text{ mA}$	5	-	10	V
		$I_{test} = -1\text{ mA}$	-10	-	-5	V
I_{LR}	reverse leakage current	per channel; $V_I = 3\text{ V}$	-	10	100	nA
		per channel; $V_I = -3\text{ V}$	-100	-10	-	nA

[1] Guaranteed by design.

Table 5. Frequency characteristics

$T_{amb} = 25\text{ }^{\circ}\text{C}$; unless otherwise specified.

Symbol	Parameter	Conditions	Min	Typ	Max	Unit
α_{il}	insertion loss	$R_{gen} = 50\ \Omega$; $R_L = 50\ \Omega$				
		$800\text{ MHz} < f_i < 1\text{ GHz}$	25	-	-	dB
		$1\text{ GHz} < f_i < 3\text{ GHz}$	30	40	-	dB
		$f_i = 0\text{ Hz}$; $V_{bias(DC)} = 0\text{ V}$	-	-	1	dB
f_{-3dB}	cut-off frequency	$R_{gen} = 50\ \Omega$; $R_L = 50\ \Omega$	[1]	-	350	MHz
α_{ct}	crosstalk attenuation	$R_{gen} = 50\ \Omega$; $R_L = 50\ \Omega$; $800\text{ MHz} < f_i < 3\text{ GHz}$	35	-	-	dB

[1] Measured relative to insertion loss at DC.

7. Application information

7.1 Insertion loss

The setup for measuring insertion loss in a 50 Ω system is shown in [Figure 6](#).

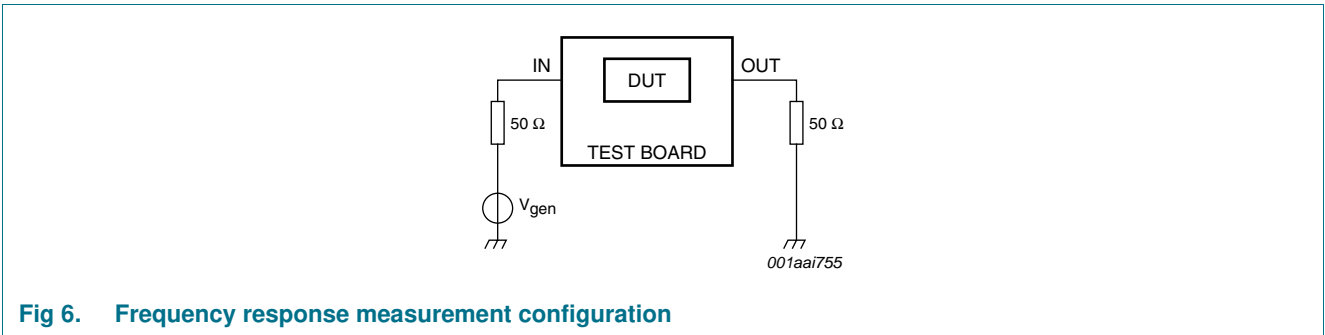

As an example, the insertion loss in a 50 Ω system for two channels of the IP3348CX15 are shown in [Figure 7](#). The insertion loss is measured directly on the wafer with coplanar probes. Unused pins are connected to ground with 50 Ω.

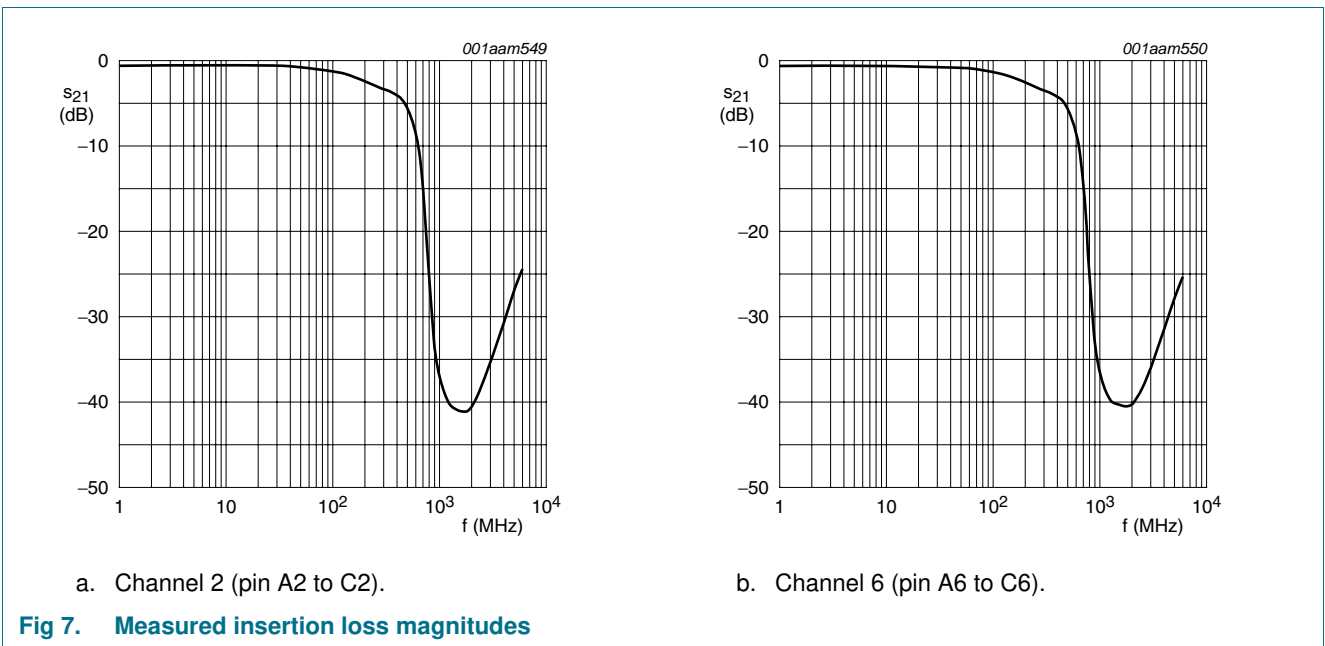

7.2 Crosstalk

The crosstalk measurement configuration of a typical 50 Ω NetWork Analyzer (NWA) system for evaluation of the IP3348CX5, IP3348CX10, IP3348CX15 and IP3348CX20 is shown in [Figure 8](#).

Four typical examples of crosstalk measurement results of IP3348CX15 are depicted. Unused channels are terminated with 50 Ω to ground.

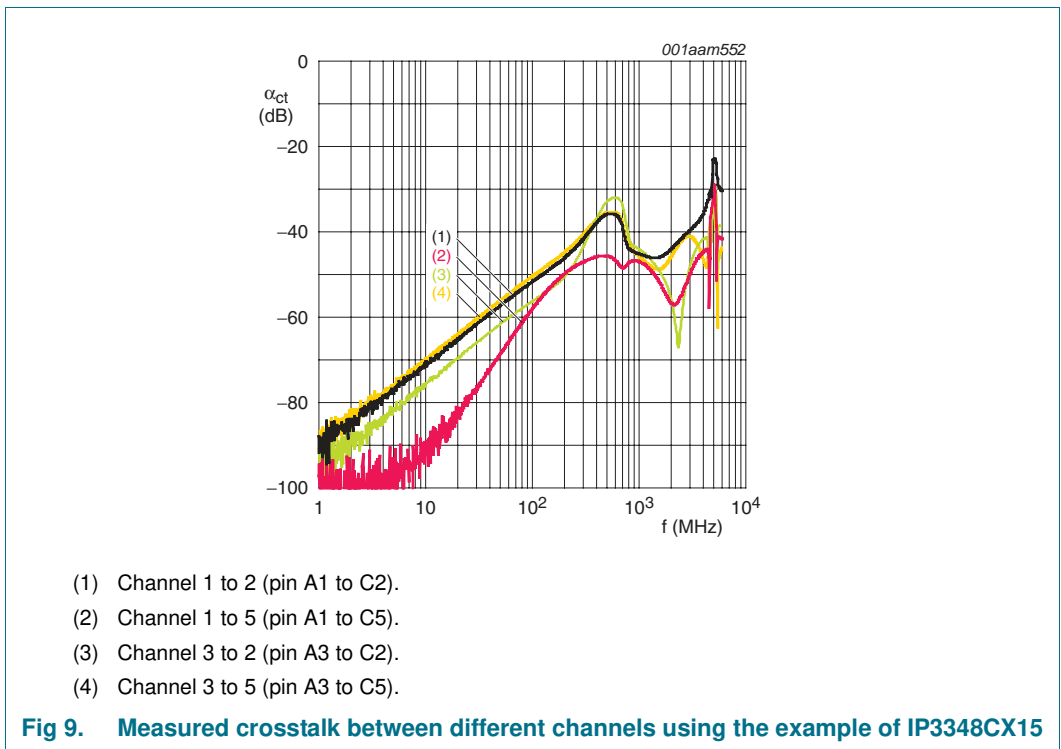
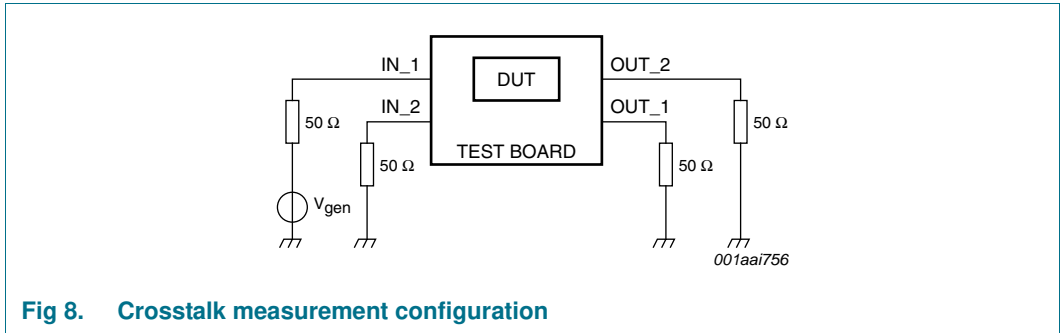

7.3 Eye diagram

The transient behavior of the IP3348CX5, IP3348CX10, IP3348CX15 and IP3348CX20 at a data rate of 400 Mbit/s is shown in [Figure 10](#) based on eye diagram measurements.

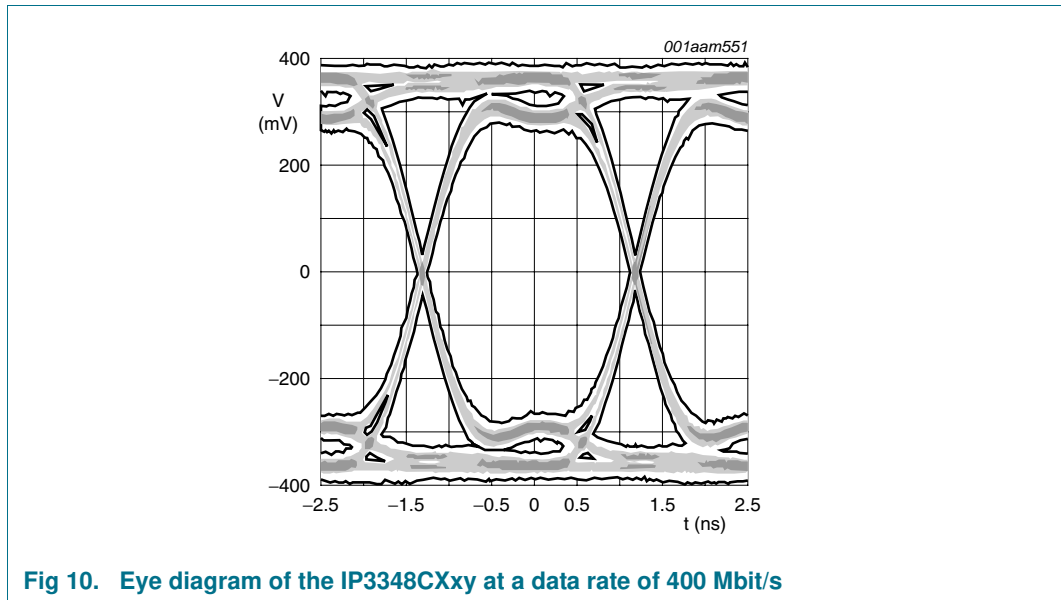

Fig 10. Eye diagram of the IP3348CXxy at a data rate of 400 Mbit/s

While [Figure 10](#) shows the eye diagram of the IP3348CXxy for a data rate of 400 Mbit/s the time characteristics for different data rates can be found in [Table 6](#).

Furthermore the percentage of time where the signal amplitude is above the MIPI receiver High-Speed (HS) mode threshold voltage of ± 70 mV is shown, too. This is a good indicator for the achievable data rate in an MIPI HS mode application.

E.g. the IP3348CXxy can be used up to a data rate of 600 Mbit/s if the receiver is able to detect bits whose amplitudes are 75 % of time above the threshold.

Table 6. Eye diagram time characteristics

T_{amb} = 25 °C; unless otherwise specified.

Data rate [Mbit/s]	Period time [ns]	Δt @ ± 70 mV [ns]	Time above MIPI HS mode threshold of ± 70 mV [%]
300	3.33	3.04	91.3
350	2.85	2.56	89.3
400	2.50	2.20	88.0
450	2.22	1.89	85.1
500	2.00	1.63	81.5
550	1.81	1.42	78.4
600	1.66	1.26	75.9

8. Package outline

WLCSP5: wafer level chip-size package; 5 bumps (2-1-2)

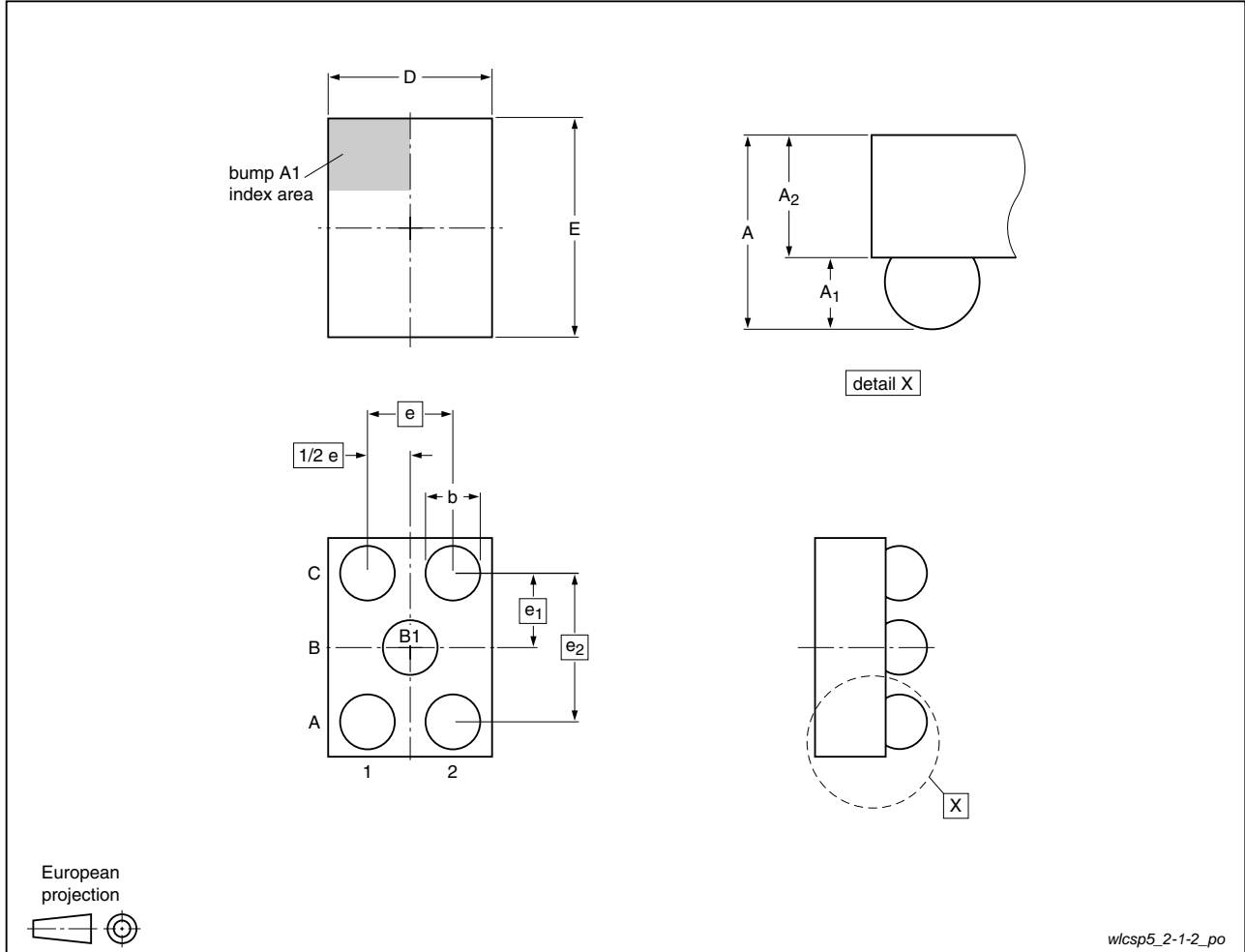

Fig 11. Package outline IP3348CX5 (WLCSP5)

Table 7. Dimensions for Figure 11

Symbol	Min	Typ	Max	Unit
A	0.57	0.61	0.65	mm
A ₁	0.18	0.20	0.22	mm
A ₂	0.39	0.41	0.43	mm
b	0.21	0.26	0.31	mm
D	0.71	0.76	0.81	mm
E	1.01	1.06	1.11	mm
e	-	0.4	-	mm
e ₁	-	0.346	-	mm
e ₂	-	0.692	-	mm

WLCSP10: wafer level chip-size package; 10 bumps (4-2-4)

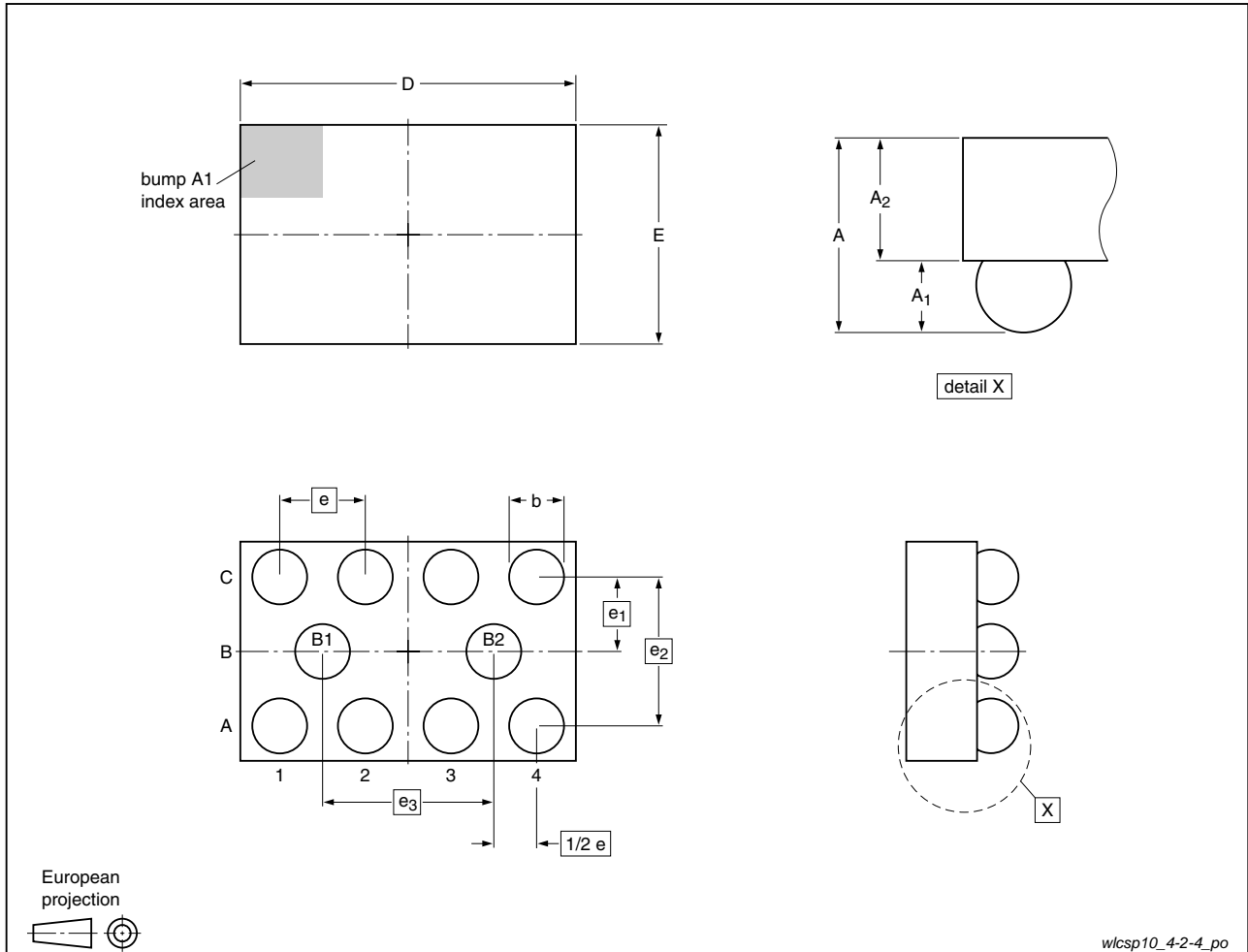

Fig 12. Package outline IP3348CX10 (WLCSP10)

Table 8. Dimensions for Figure 12

Symbol	Min	Typ	Max	Unit
A	0.57	0.61	0.65	mm
A ₁	0.18	0.20	0.22	mm
A ₂	0.39	0.41	0.43	mm
b	0.21	0.26	0.31	mm
D	1.51	1.56	1.61	mm
E	1.01	1.06	1.11	mm
e	-	0.4	-	mm
e ₁	-	0.346	-	mm
e ₂	-	0.692	-	mm
e ₃	-	0.8	-	mm

WLCSP15: wafer level chip-size package; 15 bumps (6-3-6)

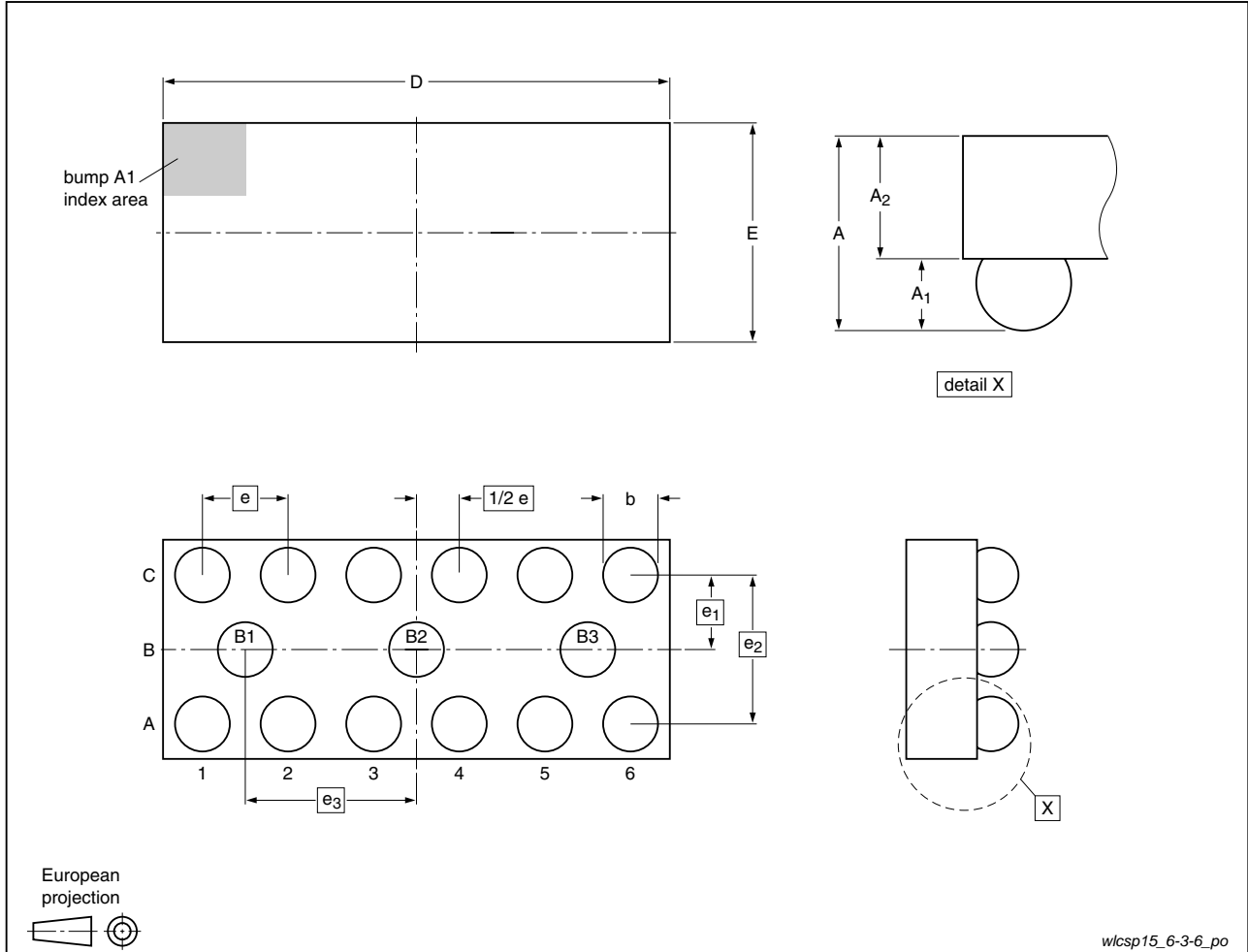

Fig 13. Package outline IP3348CX15 (WLCSP15)

Table 9. Dimensions for Figure 13

Symbol	Min	Typ	Max	Unit
A	0.57	0.61	0.65	mm
A ₁	0.18	0.20	0.22	mm
A ₂	0.39	0.41	0.43	mm
b	0.21	0.26	0.31	mm
D	2.31	2.36	2.41	mm
E	1.01	1.06	1.11	mm
e	-	0.4	-	mm
e ₁	-	0.346	-	mm
e ₂	-	0.692	-	mm
e ₃	-	0.8	-	mm

WLCSP20: wafer level chip-size package; 20 bumps (8-4-8)

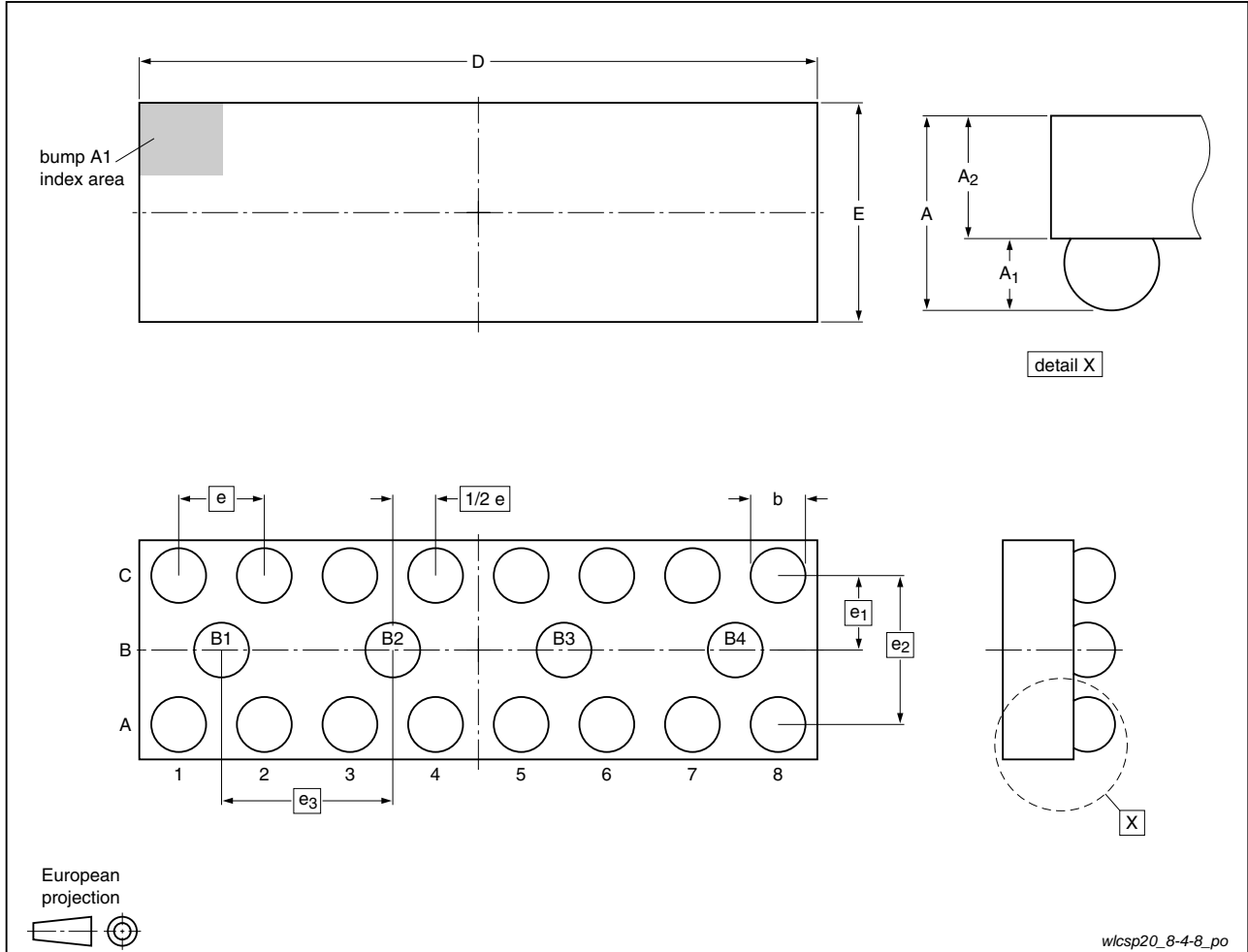

Fig 14. Package outline IP3348CX20 (WLCSP20)

Table 10. Dimensions for Figure 14

Symbol	Min	Typ	Max	Unit
A	0.57	0.61	0.65	mm
A ₁	0.18	0.20	0.22	mm
A ₂	0.39	0.41	0.43	mm
b	0.21	0.26	0.31	mm
D	3.11	3.16	3.21	mm
E	1.01	1.06	1.11	mm
e	-	0.4	-	mm
e ₁	-	0.346	-	mm
e ₂	-	0.692	-	mm
e ₃	-	0.8	-	mm

9. Design and assembly recommendations

9.1 PCB design guidelines

It is recommended, for optimum performance, to use a Non-Solder Mask Defined (NSMD), also known as a copper-defined design, incorporating laser-drilled micro-vias connecting the ground pads to a buried ground-plane layer. This results in the lowest possible ground inductance and provides the best high frequency and ESD performance. Refer to [Table 11](#) for the recommended PCB design parameters.

Table 11. Recommended PCB design parameters

Parameter	Value or specification
PCB pad diameter	250 μm
Micro-via diameter	100 μm (0.004 inch)
Solder mask aperture diameter	325 μm
Copper thickness	20 μm to 40 μm
Copper finish	AuNi
PCB material	FR4

9.2 PCB assembly guidelines for Pb-free soldering

Table 12. Assembly recommendations

Parameter	Value or specification
Solder screen aperture diameter	325 μm
Solder screen thickness	100 μm (0.004 inch)
Solder paste: Pb-free	SnAg (3 % to 4 %); Cu (0.5 % to 0.9 %)
Solder to flux ratio	50 : 50
Solder reflow profile	see Figure 15

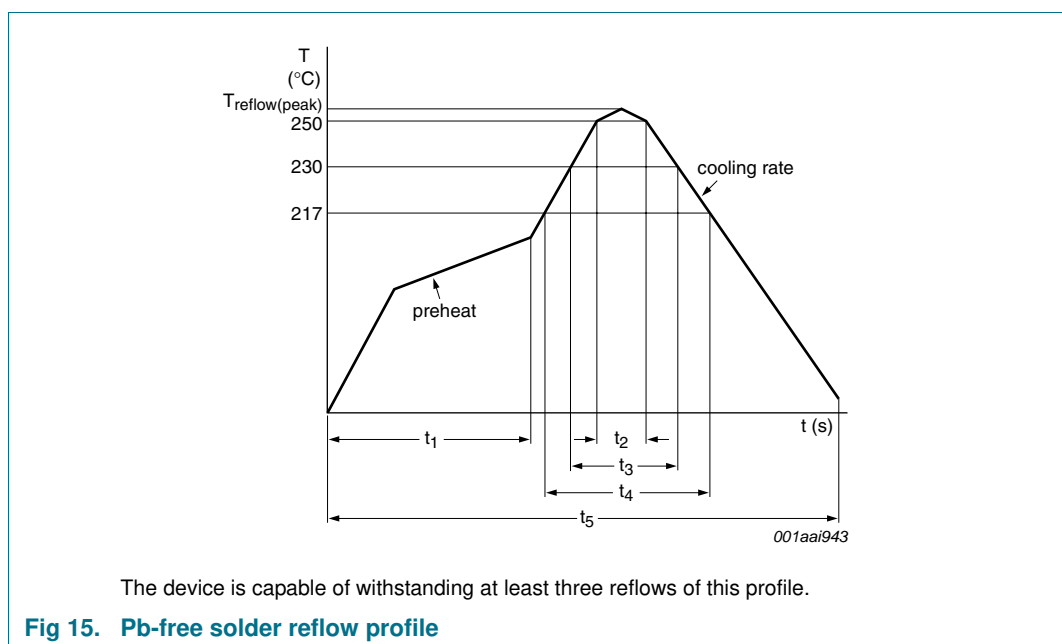

Table 13. Characteristics

Symbol	Parameter	Conditions	Min	Typ	Max	Unit
$T_{\text{reflow(peak)}}$	peak reflow temperature		230	-	260	°C
t_1	time 1	soak time	60	-	180	s
t_2	time 2	time during $T \geq 250$ °C	-	-	30	s
t_3	time 3	time during $T \geq 230$ °C	10	-	50	s
t_4	time 4	time during $T > 217$ °C	30	-	150	s
t_5	time 5		-	-	540	s
dT/dt	rate of change of temperature	cooling rate	-	-	-6	°C/s
		preheat	2.5	-	4.0	°C/s

10. Abbreviations

Table 14. Abbreviations

Acronym	Description
DUT	Device Under Test
EMI	ElectroMagnetic Interference
ESD	ElectroStatic Discharge
FR4	Flame Retard 4
HS	High-Speed
LCD	Liquid Crystal Display
MDDI	Mobile Display Digital Interface
MIPI	Mobile Industry Processor Interface
NSMD	Non-Solder Mask Defined
NWA	NetWork Analyzer
PCB	Printed-Circuit Board
RF	Radio Frequency
RoHS	Restriction of Hazardous Substances
WLCSP	Wafer-Level Chip-Scale Package

11. Revision history

Table 15. Revision history

Document ID	Release date	Data sheet status	Change notice	Supersedes
IP3348CX5_CX10_CX15_CX20 v.1.1	20110404	Product data sheet	-	IP3348CX5_CX10_CX15_CX20 v.1
Modifications:	<ul style="list-style-type: none"> • Section 1.3: Changed MIDI to MIPI 			
IP3348CX5_CX10_CX15_CX20 v.1	20101102	Product data sheet	-	-

12. Legal information

12.1 Data sheet status

Document status ^{[1][2]}	Product status ^[3]	Definition
Objective [short] data sheet	Development	This document contains data from the objective specification for product development.
Preliminary [short] data sheet	Qualification	This document contains data from the preliminary specification.
Product [short] data sheet	Production	This document contains the product specification.

[1] Please consult the most recently issued document before initiating or completing a design.

[2] The term 'short data sheet' is explained in section "Definitions".

[3] The product status of device(s) described in this document may have changed since this document was published and may differ in case of multiple devices. The latest product status information is available on the Internet at URL <http://www.nxp.com>.

12.2 Definitions

Draft — The document is a draft version only. The content is still under internal review and subject to formal approval, which may result in modifications or additions. NXP Semiconductors does not give any representations or warranties as to the accuracy or completeness of information included herein and shall have no liability for the consequences of use of such information.

Short data sheet — A short data sheet is an extract from a full data sheet with the same product type number(s) and title. A short data sheet is intended for quick reference only and should not be relied upon to contain detailed and full information. For detailed and full information see the relevant full data sheet, which is available on request via the local NXP Semiconductors sales office. In case of any inconsistency or conflict with the short data sheet, the full data sheet shall prevail.

Product specification — The information and data provided in a Product data sheet shall define the specification of the product as agreed between NXP Semiconductors and its customer, unless NXP Semiconductors and customer have explicitly agreed otherwise in writing. In no event however, shall an agreement be valid in which the NXP Semiconductors product is deemed to offer functions and qualities beyond those described in the Product data sheet.

12.3 Disclaimers

Limited warranty and liability — Information in this document is believed to be accurate and reliable. However, NXP Semiconductors does not give any representations or warranties, expressed or implied, as to the accuracy or completeness of such information and shall have no liability for the consequences of use of such information.

In no event shall NXP Semiconductors be liable for any indirect, incidental, punitive, special or consequential damages (including - without limitation - lost profits, lost savings, business interruption, costs related to the removal or replacement of any products or rework charges) whether or not such damages are based on tort (including negligence), warranty, breach of contract or any other legal theory.

Notwithstanding any damages that customer might incur for any reason whatsoever, NXP Semiconductors' aggregate and cumulative liability towards customer for the products described herein shall be limited in accordance with the *Terms and conditions of commercial sale* of NXP Semiconductors.

Right to make changes — NXP Semiconductors reserves the right to make changes to information published in this document, including without limitation specifications and product descriptions, at any time and without notice. This document supersedes and replaces all information supplied prior to the publication hereof.

Suitability for use — NXP Semiconductors products are not designed, authorized or warranted to be suitable for use in life support, life-critical or safety-critical systems or equipment, nor in applications where failure or

malfunction of an NXP Semiconductors product can reasonably be expected to result in personal injury, death or severe property or environmental damage. NXP Semiconductors accepts no liability for inclusion and/or use of NXP Semiconductors products in such equipment or applications and therefore such inclusion and/or use is at the customer's own risk.

Applications — Applications that are described herein for any of these products are for illustrative purposes only. NXP Semiconductors makes no representation or warranty that such applications will be suitable for the specified use without further testing or modification.

Customers are responsible for the design and operation of their applications and products using NXP Semiconductors products, and NXP Semiconductors accepts no liability for any assistance with applications or customer product design. It is customer's sole responsibility to determine whether the NXP Semiconductors product is suitable and fit for the customer's applications and products planned, as well as for the planned application and use of customer's third party customer(s). Customers should provide appropriate design and operating safeguards to minimize the risks associated with their applications and products.

NXP Semiconductors does not accept any liability related to any default, damage, costs or problem which is based on any weakness or default in the customer's applications or products, or the application or use by customer's third party customer(s). Customer is responsible for doing all necessary testing for the customer's applications and products using NXP Semiconductors products in order to avoid a default of the applications and the products or of the application or use by customer's third party customer(s). NXP does not accept any liability in this respect.

Limiting values — Stress above one or more limiting values (as defined in the Absolute Maximum Ratings System of IEC 60134) will cause permanent damage to the device. Limiting values are stress ratings only and (proper) operation of the device at these or any other conditions above those given in the Recommended operating conditions section (if present) or the Characteristics sections of this document is not warranted. Constant or repeated exposure to limiting values will permanently and irreversibly affect the quality and reliability of the device.

Terms and conditions of commercial sale — NXP Semiconductors products are sold subject to the general terms and conditions of commercial sale, as published at <http://www.nxp.com/profile/terms>, unless otherwise agreed in a valid written individual agreement. In case an individual agreement is concluded only the terms and conditions of the respective agreement shall apply. NXP Semiconductors hereby expressly objects to applying the customer's general terms and conditions with regard to the purchase of NXP Semiconductors products by customer.

No offer to sell or license — Nothing in this document may be interpreted or construed as an offer to sell products that is open for acceptance or the grant, conveyance or implication of any license under any copyrights, patents or other industrial or intellectual property rights.

Export control — This document as well as the item(s) described herein may be subject to export control regulations. Export might require a prior authorization from national authorities.

Non-automotive qualified products — Unless this data sheet expressly states that this specific NXP Semiconductors product is automotive qualified, the product is not suitable for automotive use. It is neither qualified nor tested in accordance with automotive testing or application requirements. NXP Semiconductors accepts no liability for inclusion and/or use of non-automotive qualified products in automotive equipment or applications.

In the event that customer uses the product for design-in and use in automotive applications to automotive specifications and standards, customer (a) shall use the product without NXP Semiconductors' warranty of the product for such automotive applications, use and specifications, and (b) whenever customer uses the product for automotive applications beyond

NXP Semiconductors' specifications such use shall be solely at customer's own risk, and (c) customer fully indemnifies NXP Semiconductors for any liability, damages or failed product claims resulting from customer design and use of the product for automotive applications beyond NXP Semiconductors' standard warranty and NXP Semiconductors' product specifications.

12.4 Trademarks

Notice: All referenced brands, product names, service names and trademarks are the property of their respective owners.

13. Contact information

For more information, please visit: <http://www.nxp.com>

For sales office addresses, please send an email to: salesaddresses@nxp.com

14. Contents

1 Product profile 1

1.1 General description 1

1.2 Features and benefits 1

1.3 Applications 1

2 Pinning information 2

2.1 Pinning 2

2.2 Pin description 2

3 Ordering information 3

4 Functional diagram 3

5 Limiting values 3

6 Characteristics 4

7 Application information 5

7.1 Insertion loss 5

7.2 Crosstalk 6

7.3 Eye diagram 7

8 Package outline 8

9 Design and assembly recommendations . . . 12

9.1 PCB design guidelines 12

9.2 PCB assembly guidelines for Pb-free soldering 12

10 Abbreviations 13

11 Revision history 13

12 Legal information 14

12.1 Data sheet status 14

12.2 Definitions 14

12.3 Disclaimers 14

12.4 Trademarks 15

13 Contact information 15

14 Contents 16

Please be aware that important notices concerning this document and the product(s) described herein, have been included in section 'Legal information'.

© NXP B.V. 2011. All rights reserved.

For more information, please visit: <http://www.nxp.com>
 For sales office addresses, please send an email to: salesaddresses@nxp.com

Date of release: 4 April 2011
 Document identifier: IP3348CX5_CX10_CX15_CX20