

THIS DRAWING IS UNPUBLISHED. RELEASED FOR PUBLICATION  
 © COPYRIGHT - By - ALL RIGHTS RESERVED.

LOC		DIST		REVISIONS			
P	LTR	DESCRIPTION	DATE	DWN	APVD		
AF	50	A2	ECR-13-016672	25OCT13	PKS	RRP	

- 1 SLOT ACCEPTS A 0.54-0.64mm [#23.5-#22] AWG COPPER MAGNET WIRE.
- 2 MATES WITH STANDARD MAG-MATE STYLED POKE-IN TAB TERMINAL.
- 3 WHEN FREE STATE IS COMPRESSED TO 3.23 [.127] DIMENSION GAP BETWEEN SPRING AND CARRIER IS TO BE 0.30 [.012] MAX.
- 4 TIN PLATE OVER NICKEL UNDERPLATE.

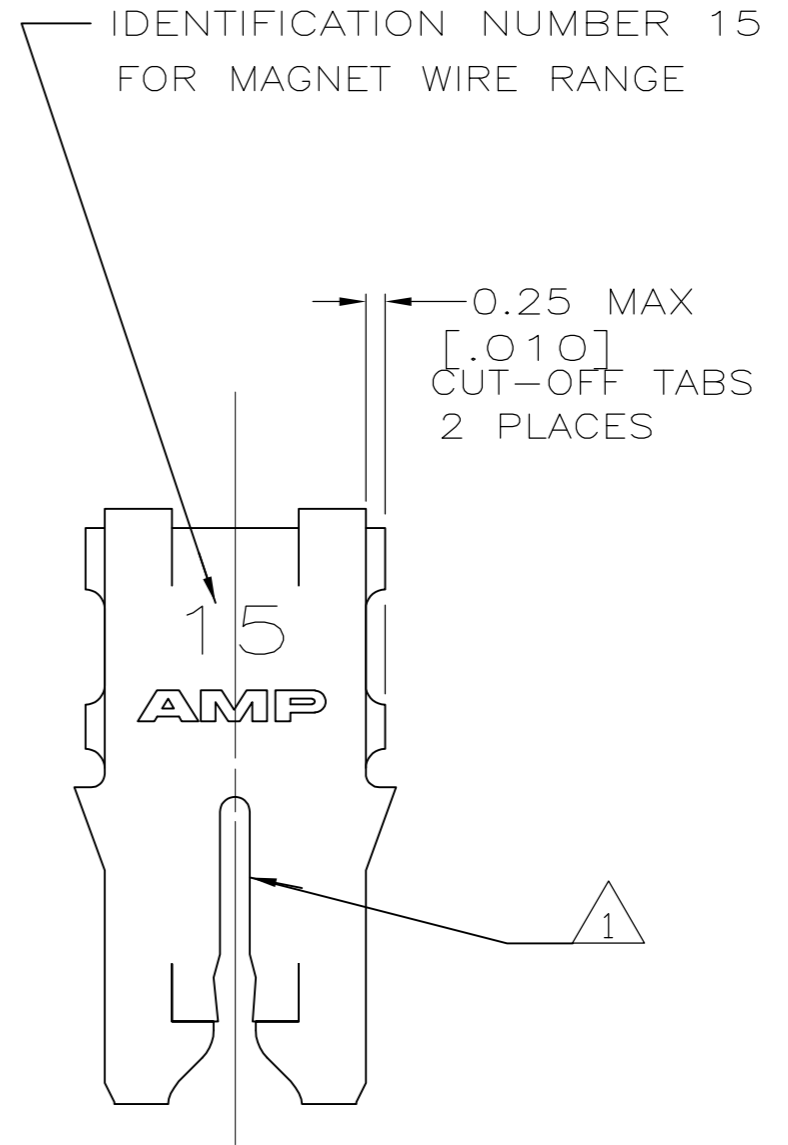
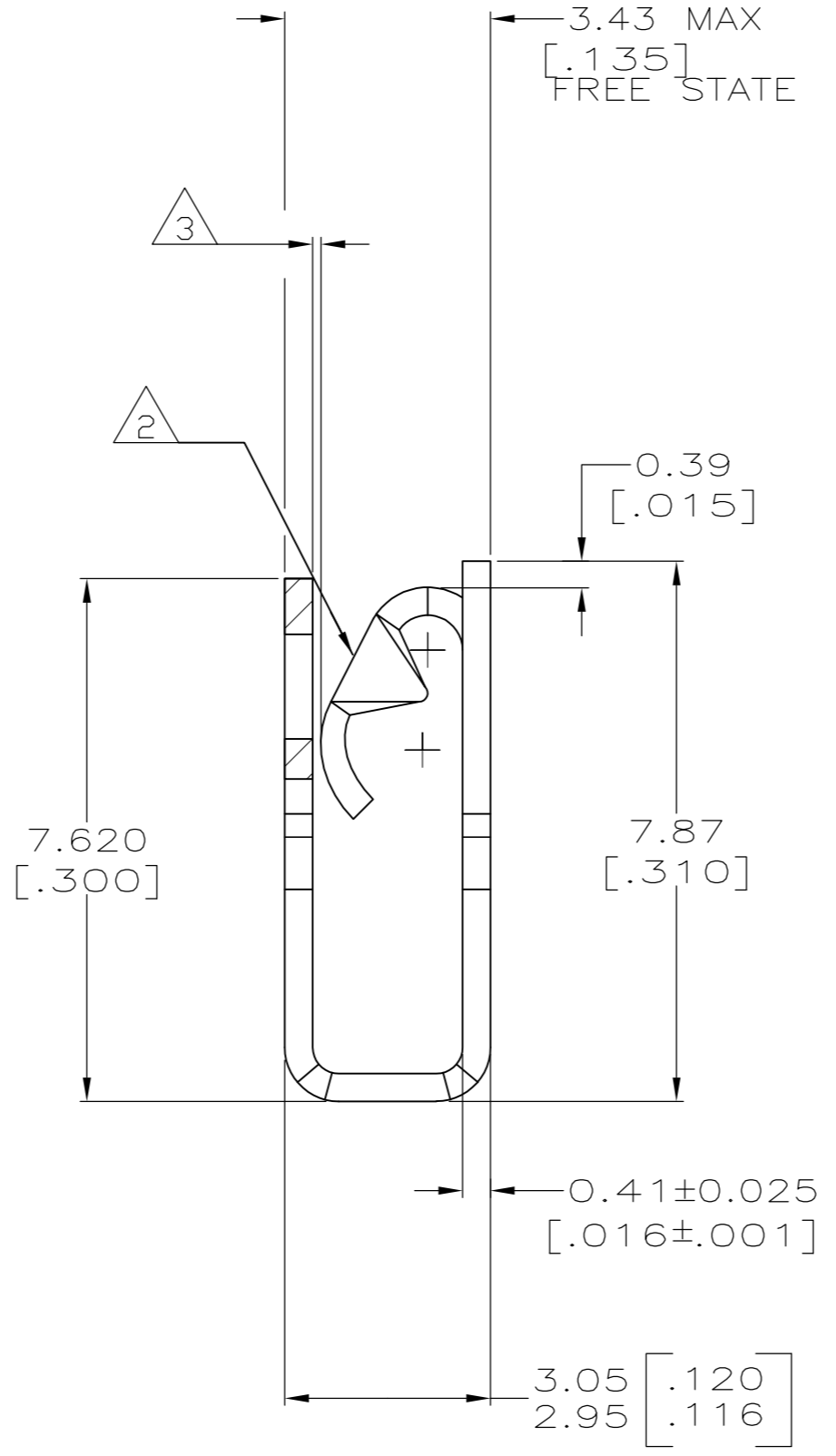
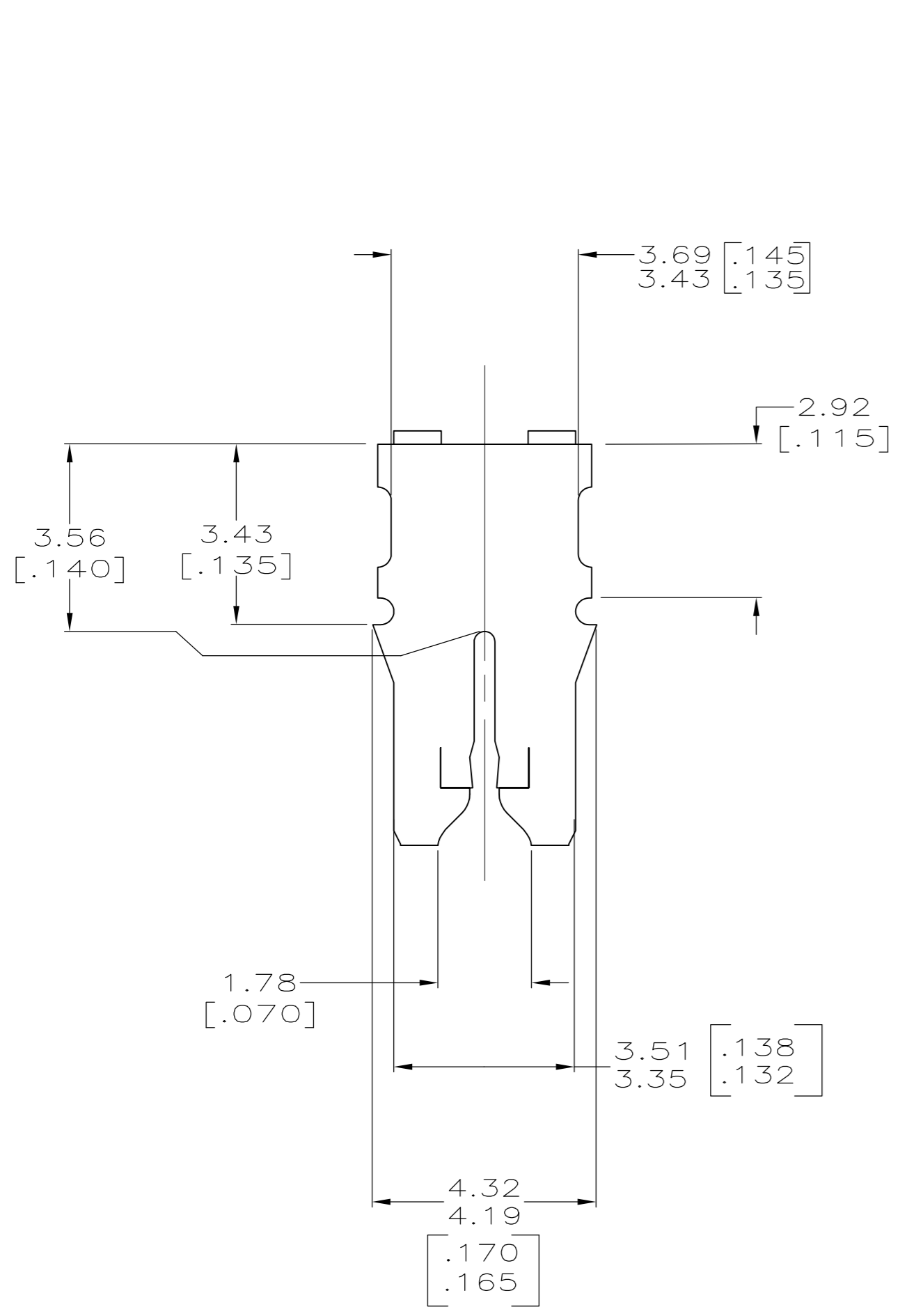
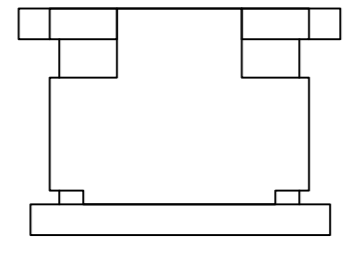

1742483-1  
 PART NUMBER

THIS DRAWING IS A CONTROLLED DOCUMENT.		DWN MICHAEL S. FEHER 09NOV2006	<b>TE</b> TE Connectivity	
DIMENSIONS: mm		CHK KURT A. RANDOLPH 09NOV2006		
TOLERANCES UNLESS OTHERWISE SPECIFIED:		APVD KURT A. RANDOLPH 09NOV2006	NAME SPECIAL LEAF CONTACT, LOOSE PIECE, 300 SERIES MAG-MATE	
0 PLC ± -		PRODUCT SPEC 108-2012	SIZE A2	CAGE CODE 00779
1 PLC ± -		APPLICATION SPEC 114-2046	DRAWING NO C=1742483	
2 PLC ± 0.25[.010]		WEIGHT -	RESTRICTED TO -	
3 PLC ± -		MATERIAL BRASS	SCALE 10:1	SHEET 1 of 1
4 PLC ± -		FINISH - 4	REV A2	
ANGLES ± -		CUSTOMER DRAWING		