

**B** MAJ-17-00

ITEM	PART NO.	QTY	DESCRIPTION
1	MAJ-10-32	1	O-RING, PANEL MOUNT
2	MAJ-10-33	1	NUT, PM-MAJ
3	MAJ-17-01	1	7 COND. REC. PM

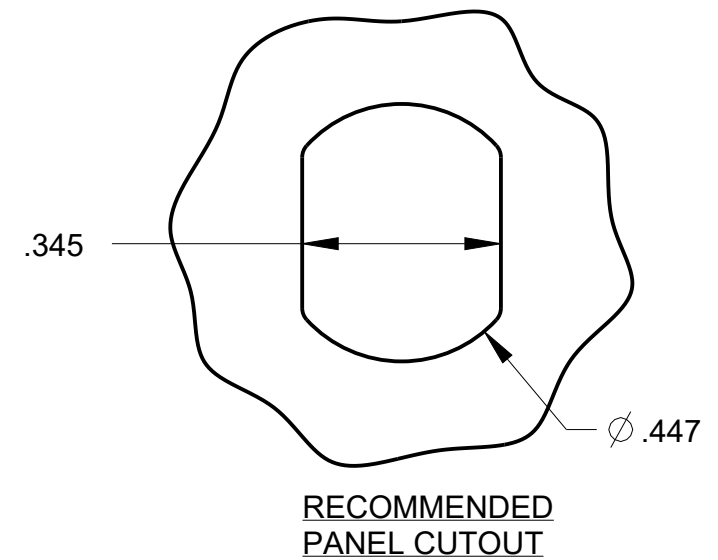

$\phi .034 \pm .005$   
PIN DIAMETER

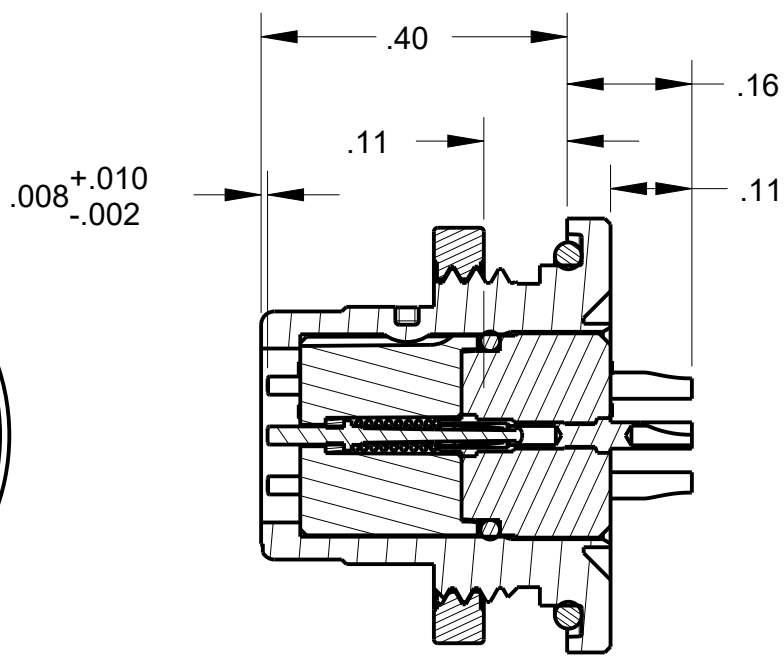
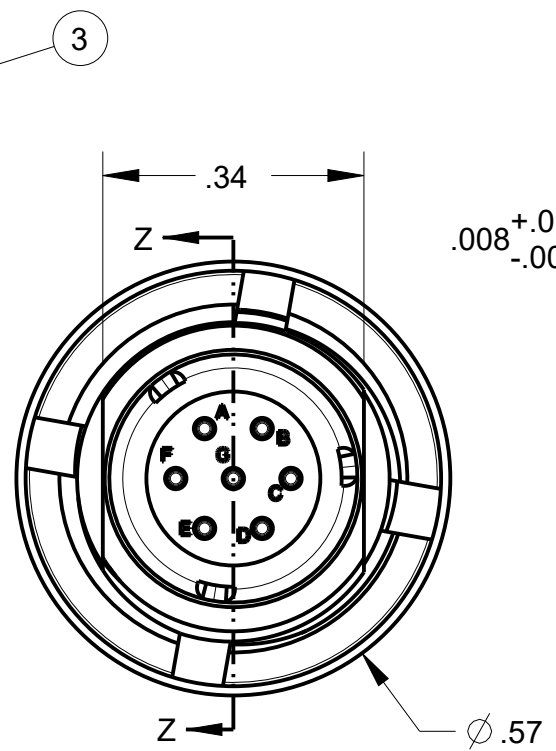
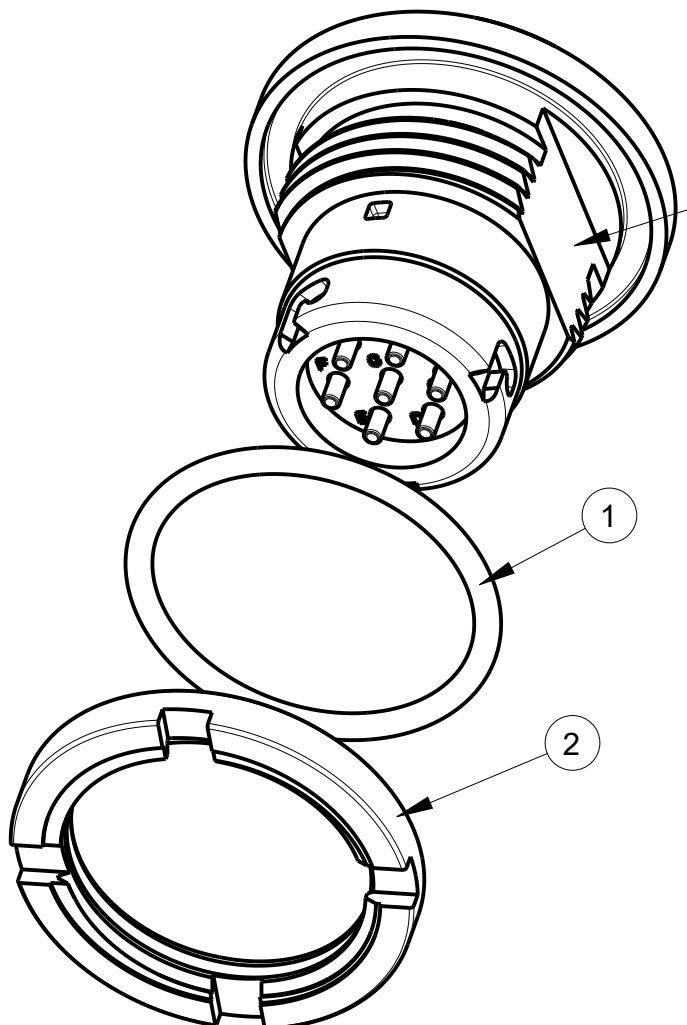
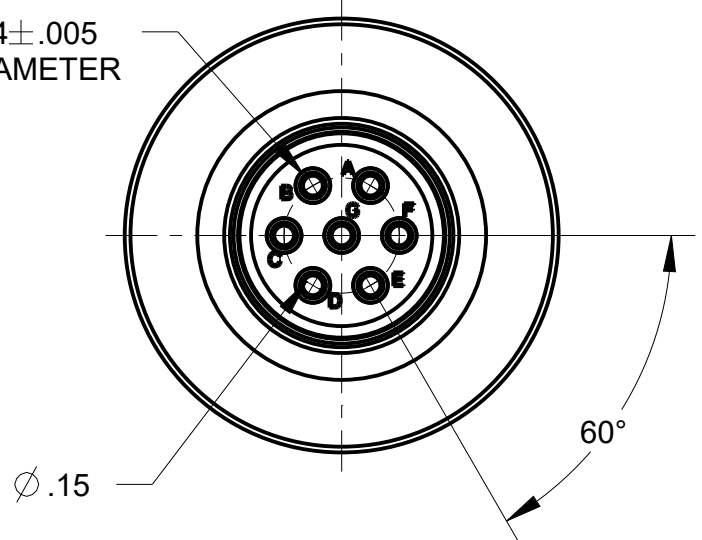

THIS DOCUMENT CONTAINS PROPRIETARY INFORMATION OF NEXUS, INCORPORATED AND SUCH INFORMATION MAY NOT BE DISCLOSED TO OTHERS FOR ANY PURPOSE OR USED FOR ANY PURPOSE WITHOUT THE WRITTEN CONSENT OF NEXUS.

LET.	REVISION	CN #	DATE	CHK.
H	ADD PIN HOLE LOCATIONS		6/5 2019	BAM
G	ADD: .008+.010/-.002		9/26 2017	HR
F	CHG BOM		9/6 2011	HR
E	ADD BALLOONS	096	1/31 2011	HR
D	ASSIGN LETTERS TO CONTACTS		09/10 2010	
C	ADD MAT'L		06/04 2010	

DWN.BY	LDE	DATE	5/10/10
CHECKED BY		DATE	
APPR.BY		DATE	
UNLESS OTHERWISE SPECIFIED: DIMENSIONS ARE IN INCHES &/OR (mm)			
TOLERANCES: DECIMAL: .XX[X.X] .XXX[X.XX] ±.01[0.3] ±.003[0.08]			
FRACTION: X/X ±1/64		ANGLES: X ±.5	

MATERIAL	
FINISH	
WEIGHT	SCALE = 4.00 : 1
TITLE 7 COND. REC. PANEL MOUNT	
DO NOT SCALE DWG.	SHEET 1 OF 1

**NEXUS**  
STAMFORD, CONN

SIZE **B** DWG. NO. MAJ-17-00