

PAGE 1/2

ISSUE 22-03-22

SERIE : SPnT

PART NUMBER : R574103300

RF CHARACTERISTICS

Number of ways : **3**
 Frequency range : **0 - 12.4 GHz**
 Impedance : **50 Ohms**

Frequency (GHz)	DC - 3	3 - 8	8 - 12.4
VSWR max	1.20	1.35	1.50
Insertion loss max	0.20 dB	0.35 dB	0.50 dB
Isolation min	80 dB	70 dB	60 dB
Average power (*)	400 W	250 W	200 W

TERMINATION IMPEDANCE : **50 Ohms**
 TERM. AVG. POWER AT 25° C : **1 W per termination / 3 W total power**

ELECTRICAL CHARACTERISTICS

Actuator : **NORMALLY OPEN**
 Nominal current ** : **102 mA**
 Actuator voltage (Vcc) : **28V (24 to 30V) / NEGATIVE COMMON**
 Terminals : **solder pins (250°C max. / 30 sec.)**

MECHANICAL CHARACTERISTICS

Connectors : **N female per MIL-C 39012**
 Life : **2 million cycles per position**
 Switching Time*** : **< 15 ms**
 Construction : **Splashproof**
 Weight : **< 460 g**

ENVIRONMENTAL CHARACTERISTICS

Operating temperature range : **-40°C to +85°C**
 Storage temperature range : **-55°C to +85°C**

(* Average power at 25°C per RF Path)
 (** At 25° C ±10%)
 (***) Nominal voltage ; 25° C)



PAGE 2/2

ISSUE 22-03-22

SERIE : SPnT

PART NUMBER : R574103300

DRAWING

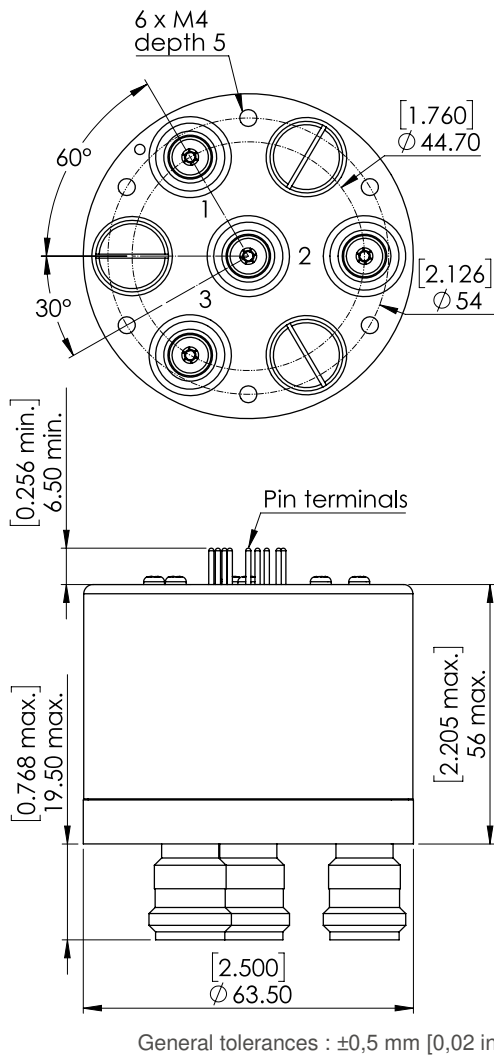

Voltage	RF Continuity
-C +1	IN ↔ 1
-C +2	IN ↔ 2
-C +3	IN ↔ 3

LABEL

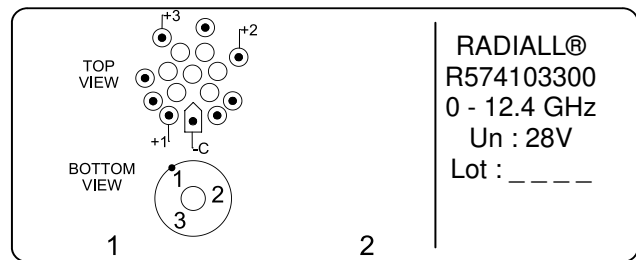

SCHEMATIC DIAGRAM

