

U92 - A 410 - 1X01 - XX

OPTIONAL DUST COVER

- 0 - NO DUST COVER
- D - WITH DUST COVER (SHIPPED BULK IN SAME BOX WITH CAGE & CONNECTOR ASSEMBLY)

MOUNTING SCREWS

- 0 - NO MOUNTING SCREWS SHIPPED
- 1 - WITH MOUNTING SCREWS M2 X 04 - 4.3 MM LONG SHIPPED BULK IN SAME TRAY WITH CAGE ASSEMBLIES

CONTACT PLATING

- 1 - MATING AREA PLATING: 0.76 µm GOLD OVER 2.54 µm OF NICKEL
PRESS FIT TAIL AREA PLATING: 0.76 µm TIN LEAD OVER 2.54 µm OF NICKEL
- 2 - MATING AREA PLATING: 0.38 µm GOLD OVER 2.54 µm OF NICKEL
PRESS FIT TAIL AREA PLATING: 0.76 µm TIN LEAD OVER 2.54 µm OF NICKEL
- 3 - MATING AREA PLATING: 0.76 µm GOLD OVER 1.27 µm TO 3.81 µm OF NICKEL
PRESS FIT TAIL AREA PLATING: 0.381 µm TO 1.52 µm OF MATTE TIN OVER 1.27 µm TO 3.81µm OF NICKEL

REVISIONS			
REV.	DESCRIPTION	DATE	APPROVED
C	SCREW LENGTH REMOVED	MAR 19/10	ZLJ
D	MODIFIED DIMENSION	SEPT 20/10	ZLJ
E	UPDATED DRAWING NUMBER	OCT 28/10	ZLJ
F	LEAD FREE CONTACT PLATING OPTION ADDED	JUL 04/11	ZLJ
G	23X 0.57 HOLE CHANGED TO 18X	JUL 29/11	ADRIAN G
H	NOTES ADDED AND VIEWS UPDATED	SEP 15/11	
J	TOLERANCES ADDED TO PCB HOLES	OCT 20/11	
K	DRAWING TITLES REVISED	OCT 21/11	
L	AHSI DESIGNATION ADDED	MAY 15/12	ZLJ

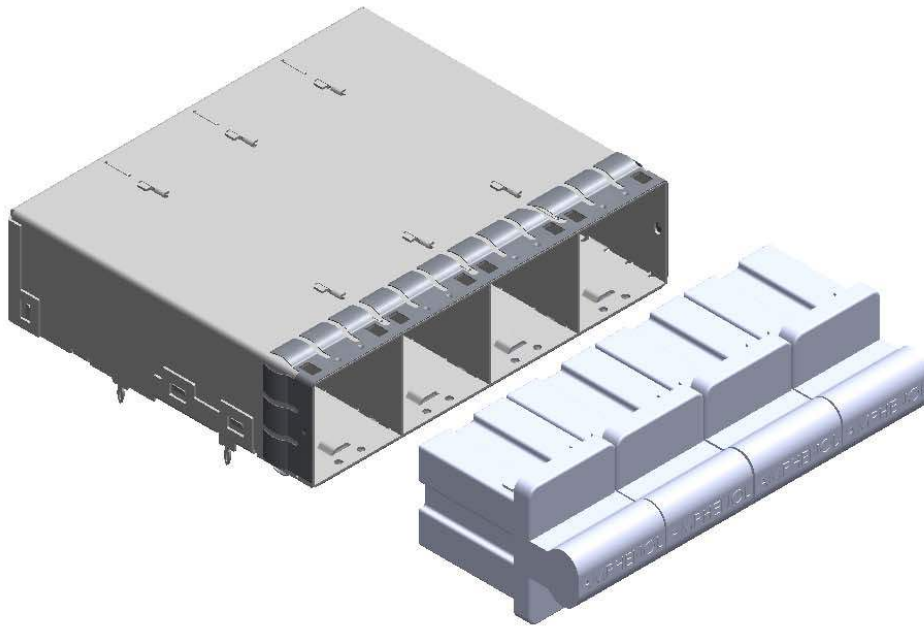

PART # U92-A410-1D01-10 SHOWN
(CAGE & CONNECTOR ASSEMBLY WITH NO SCREWS AND DUST COVER SHIPPED BULK)

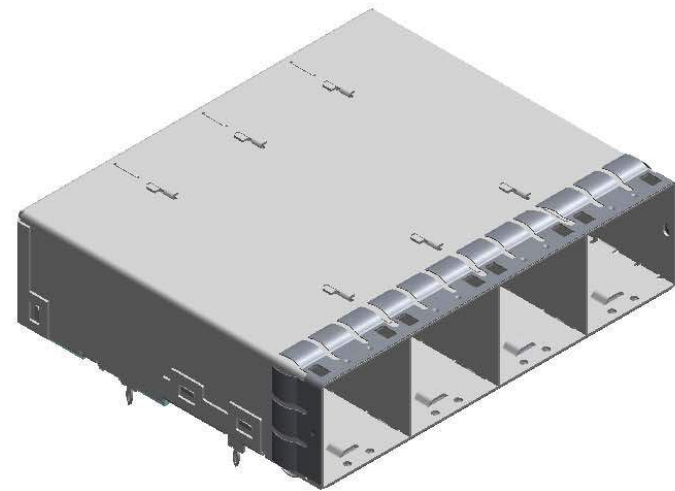

PART # U92-A410-1001-10 SHOWN
(CAGE & CONNECTOR ASSEMBLY WITH NO SCREWS AND NO DUST COVER SHIPPED)



UNLESS OTHERWISE SPECIFIED: DIMENSIONS ARE IN MILLIMETERS TOLERANCES ARE:		APPROVAL	DATE
DECIMALS	ANGLES	DRAWN: K.SOBEL	FEB 09/10
.X ±0.2	X° ±1°	CHECKED: ZLJ	FEB 09/10
.XX ±0.1	X.X° ±0.5°	QA APPR:	
		ME APPR:	
		DWG APPR: A.G.	FEB 09/10
 DO NOT SCALE DRAWING		ENG. REL. NO.	SIZE
		NSCM:	DWG. NO.

Amphenol High Speed Interconnects A Division of Amphenol Corp. www.amphenol-highspeed.com			
16X MINI SAS HD CAGE AND CONNECTOR 4 PORT ASSEMBLY			
SCALE: 1:1	PROJECT: HD	PART NO: P-U92-A410-1X01-XX	REV: L
SHEET 1 OF 4			

8 7 6 5 4 3 2 1

REVISIONS			
REV.	DESCRIPTION	DATE	APPROVED
L	SEE SHEET ONE	MAY 15/12	ZLJ

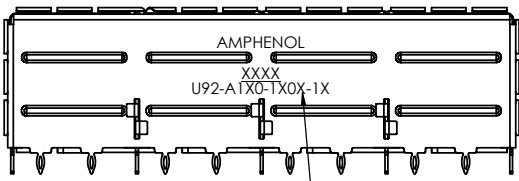
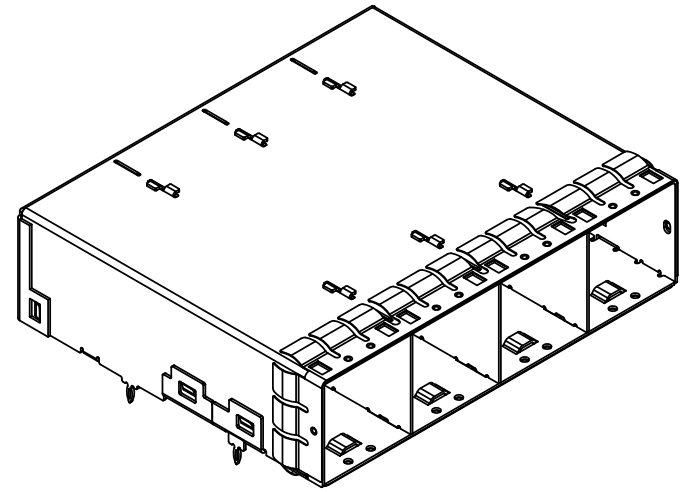
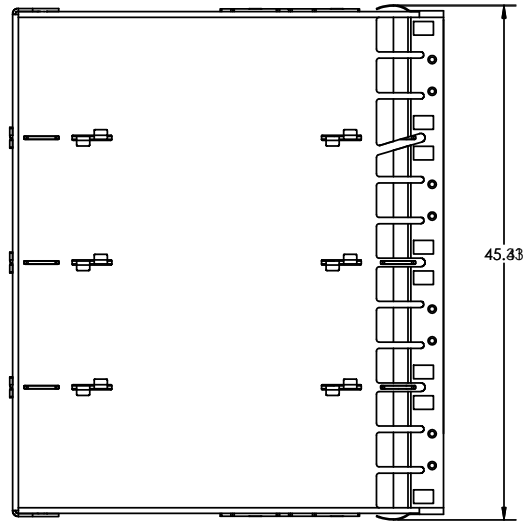

INK MARKING INFO:
FOUR (4) DIGIT DATE CODE AND PART NUMBER

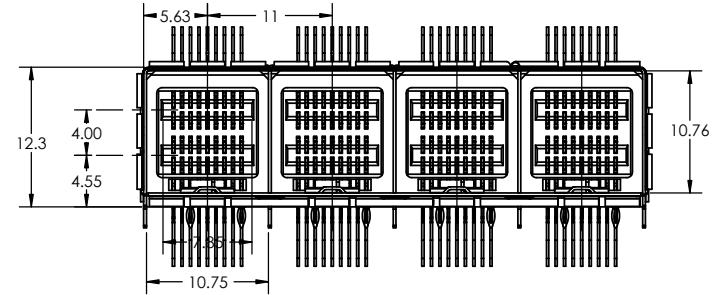
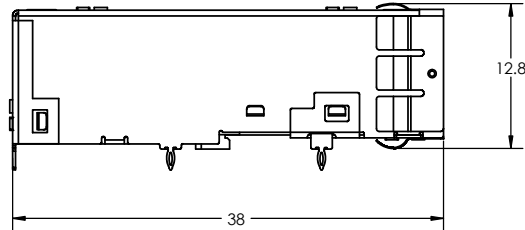

UNLESS OTHERWISE SPECIFIED: DIMENSIONS ARE IN MILLIMETERS TOLERANCES ARE:		APPROVAL	DATE	Amphenol High Speed Interconnects A Division of Amphenol Corp. www.amphenol-highspeed.com	
DECIMALS	ANGLES	DRAWN K.SOBEL	FEB 09/10		
.X ±0.2	X° ±1°	CHECKED ZLJ	FEB 09/10	16X MINI SAS HD CAGE AND CONNECTOR 4 PORT ASSEMBLY	
.XX ±0.1	X.X° ±0.5°	ME APPR.			
		DWG APPR. A.G.	FEB 09/10		
 DO NOT SCALE DRAWING		ENG. REL. NO.		SIZE	DWG. NO.
		NSCM:			P-U92-A410-1X01-XX
				SCALE: 2:1	PROJECT: HD
				SHEET 2 OF 4	

THIS DOCUMENT CONTAINS PROPRIETARY INFORMATION AND SUCH INFORMATION MAY NOT BE DISCLOSED TO OTHERS FOR ANY PURPOSE OR USED FOR MANUFACTURING PURPOSES WITHOUT WRITTEN PERMISSION FROM AMPHENOL CANADA CORP.

8 7 6 5 4 3 2 1

REVISIONS			
REV.	DESCRIPTION	DATE	APPROVED
L	SEE SHEET ONE	MAY 15/12	ZLJ

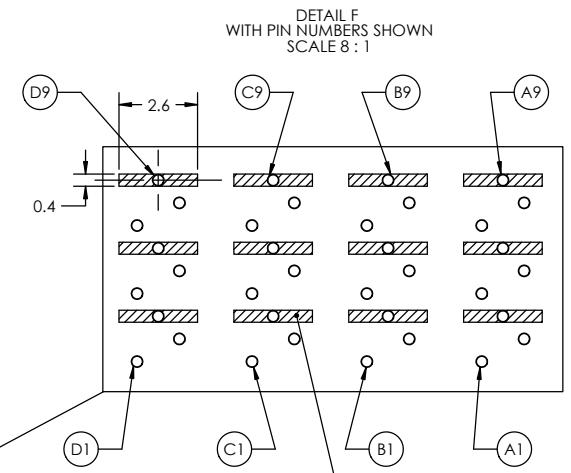
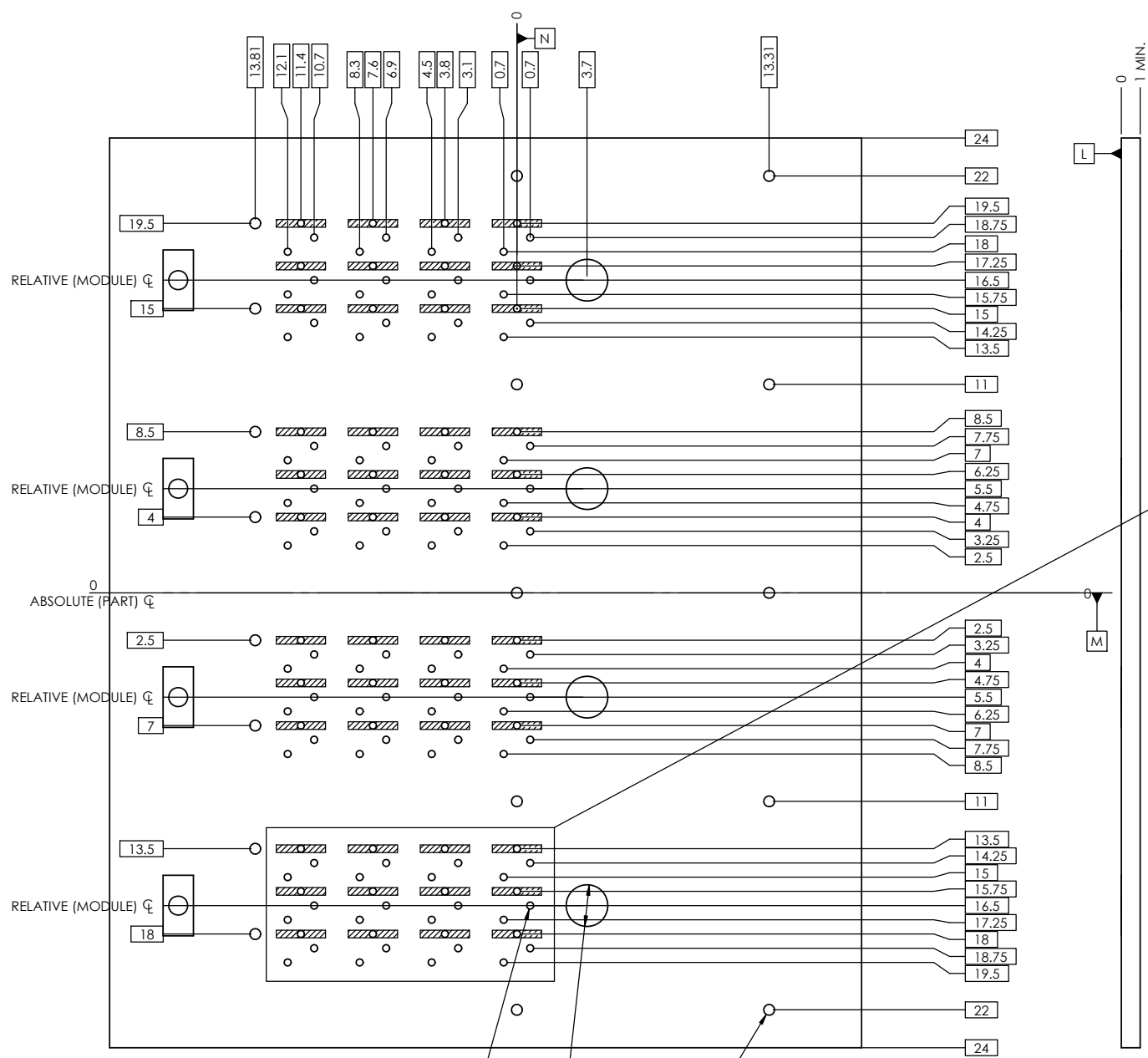

CROSS-HATCHED AREA DENOTES COMPONENT AND TRACE KEEP-OUT

NOTES:

1. ALL HOLES MUST FALL WITHIN POSITIONAL TOLERANCES RELATIVE TO INDIVIDUAL CONNECTOR ASSEMBLY AS WELL AS COMPLETED CAGE ASSEMBLY.
2. DATUM M AND N ESTABLISHED BY CUSTOMER'S FUDICIAL.
3. ALL HOLE DIMENSIONS DENOTE FINISHED HOLE SIZES.



144 X $\phi 0.37 \pm 0.05$
 $\oplus 0.05$ L | M
 $\oplus 0.05$ REL. ϕ (SEE NOTE 1)

4 X $\phi 2.2$
 $\oplus 0.05$ L | M | N

18 X $\phi 0.57 \pm 0.05$
 $\oplus 0.05$ L | M | N
 $\oplus 0.05$ REL. ϕ (SEE NOTE 1)

RECOMMENDED 4 PORT MOUNT
 PCB LAYOUT
 COMPONENT SIDE SHOWN

UNLESS OTHERWISE SPECIFIED:
 DIMENSIONS ARE IN MILLIMETERS
 TOLERANCES ARE:

DECIMALS	ANGLES
.X ± 0.2	X° $\pm 1^\circ$
.XX ± 0.1	X.X° $\pm 0.5^\circ$

APPROVAL	DATE
DRAWN: K.SOBEL	FEB 09/10
CHECKED: ZLJ	FEB 09/10
GA APPR:	
ME APPR:	
DWG APPR: A.G.	FEB 09/10
ENG. REL. NO.	
NSCM:	

Amphenol High Speed Interconnects
 A Division of Amphenol Corp. www.amphenol-highspeed.com

16X MINI SAS HD
 CAGE AND CONNECTOR
 4 PORT ASSEMBLY

SIZE	DWG. NO.	P-U92-A410-1X01-XX	REV	L
SCALE: 2:1	PROJECT: HD	SHEET 3 OF 4		

REVISIONS			
REV.	DESCRIPTION	DATE	APPROVED
L	SEE SHEET ONE	MAY 15/12	ZLJ

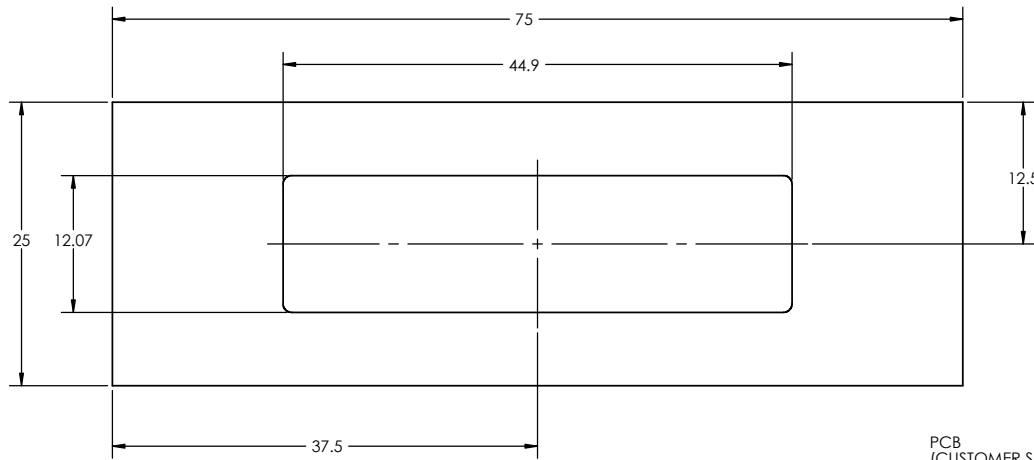

RECOMMENDED PANEL CUTOUT FOR SINGLE LEVEL MOUNTING

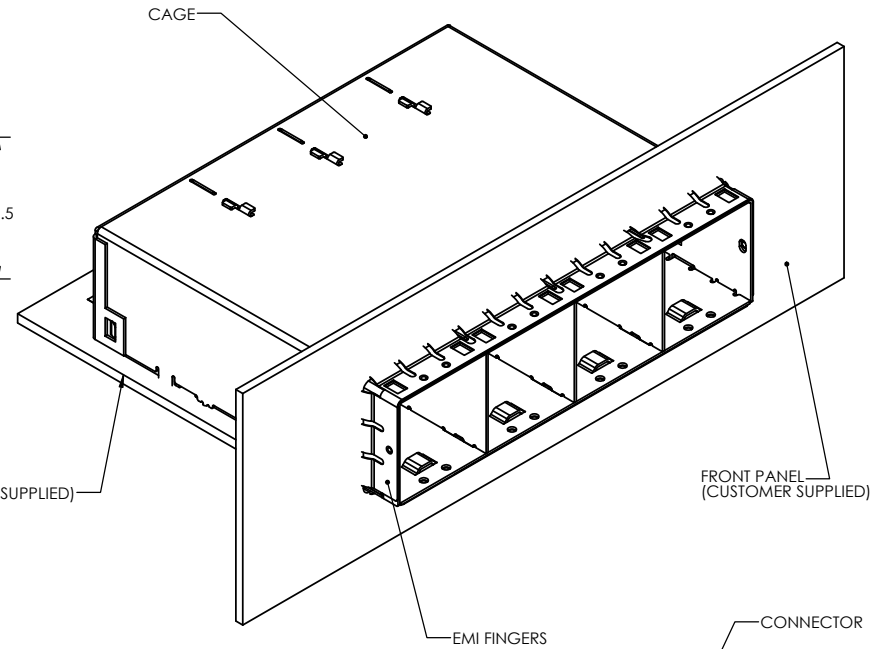

PCB (CUSTOMER SUPPLIED)

FRONT PANEL (CUSTOMER SUPPLIED)

EMI FINGERS

CONNECTOR

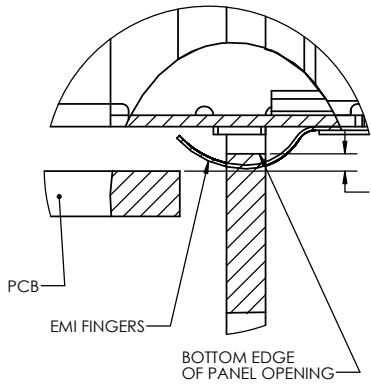

DETAIL G SCALE 12:1

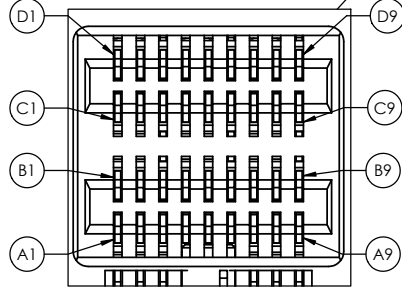
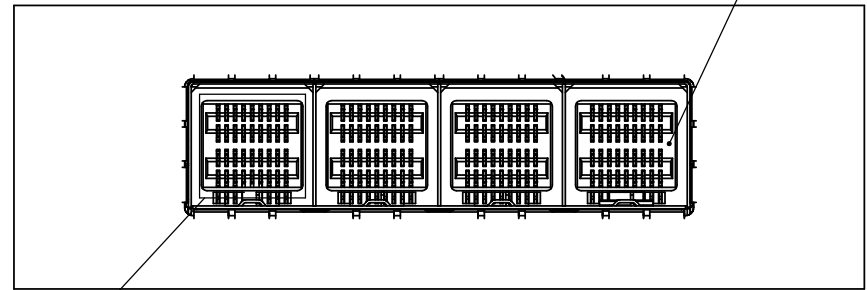
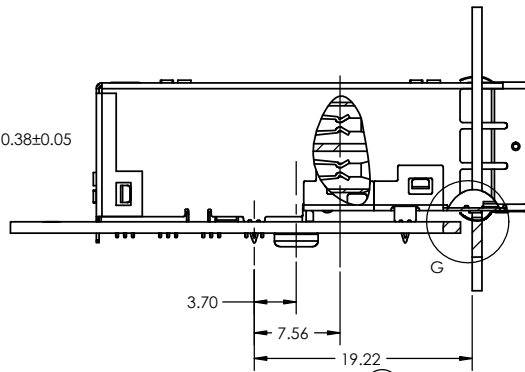

DETAIL VIEW WITH PIN NUMBERS SHOWN SCALE 8:1

NOTES:

1) MATERIAL

MAIN CAGE: PHOSPHOR BRONZE WITH NICKEL PLATING

MOUNTING SCREW: AISI 1010 STEEL

CONNECTOR HOUSING: LCP

CONTACTS: PHOSPHOR BRONZE, FOR PLATING INFO. SEE SHEET ONE

2) CONNECTOR AND CAGE ASSEMBLY ARE RoHS COMPLIANT



UNLESS OTHERWISE SPECIFIED:
DIMENSIONS ARE IN MILLIMETERS
TOLERANCES ARE:

DECIMALS .X ±0.2
ANGLES X° ±1°
.XX ±0.1 X.X° ±0.5°

APPROVAL	DATE
DRAWN: K.SOBEL	FEB 09/10
CHECKED: ZLJ	FEB 09/10
QA APPR:	
ME APPR:	
DWG APPR: A.G.	FEB 09/10
ENG. REL. NO.	
NSCM:	

Amphenol High Speed Interconnects
A Division of Amphenol Corp. www.amphenol-highspeed.com

16X MINI SAS HD
CAGE AND CONNECTOR
4 PORT ASSEMBLY

DO NOT SCALE DRAWING

SIZE	DWG. NO.	PROJECT	REV
SCALE: 1:1	P-U92-A410-1X01-XX	HD	L