

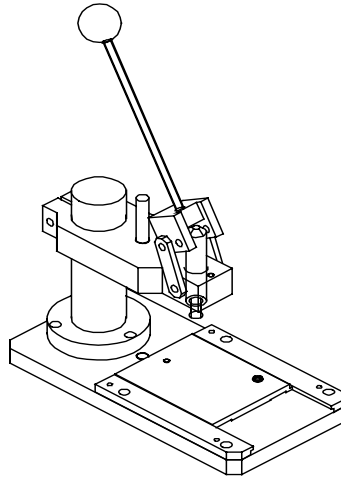

ARBOR PRESS PART No. 69020-0660

FOR MOLEX ARBOR PRESS FIXTURES



DESCRIPTION

This Arbor Press will accept Molex Arbor Press Fixtures 69020-XXXX.

FEATURES

1. Modular design with a selection of fixtures available for Molex products.
2. Small to medium production at low cost.
3. Production rates of 100 to 400 assemblies per hour (dependant on fixture type and operator).
4. Manual operation only.

SPECIFICATION

SIZE: 152mm x 300mm x 230mm

WEIGHT: 5Kg

WORKING SERVICES: None

SET-UP

- 1) This Arbor Press is not supplied with a fixture for terminating Molex products.
- 2) To install a fixture, please read the instructions supplied with the fixture.

OPERATION

- 1) The operation of this manual press (with a fixture fitted) is to pull the handle down fully and then back to the start position.
- 2) Please read the instructions supplied with the fixture to be used.

ADJUSTMENTS

- 1) When fitting a fixture, please follow the set-up instructions in the fixture manual.
- 2) Adjustments are also given in the fixture manual.
- 3) Two methods of stroke adjustment are available.
 - b. Course adjustment by means of a threaded rod to set the distance between the upper and lower parts of the press.
 - c. A limit stop set the bottom position of the handle stroke.

A combination of these two adjustments can be used to set the fixture termination or operating depth.

MAINTENANCE

- 1) Keep Arbor Press clean at all times.
- 2) Clean Arbor Press with a soft brush.
- 3) Oil moving parts weekly, when in use.
- 4) Store in a clean dry environment.

QUALITY

Check termination quality against the Molex wire termination specification for relevant product being terminated e.g.: PS-90650.

A quality procedure should be in place to monitor output from this Arbor Press.