

ADC080x 8-Bit, μ P-Compatible, Analog-to-Digital Converters

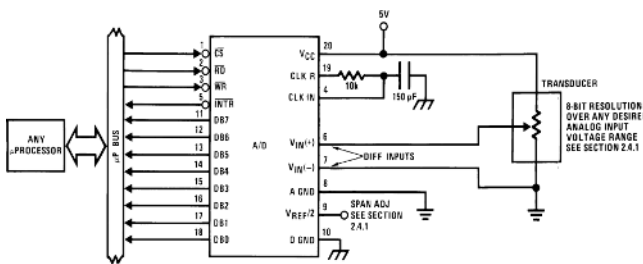
1 Features

- Compatible With 8080- μ P Derivatives – No Interfacing Logic Needed – Access Time 135 ns
- Easy Interface to All Microprocessors, or Operates as a Stand-Alone Device
- Differential Analog Voltage Inputs
- Logic Inputs and Outputs Meet Both MOS and TTL Voltage-Level Specifications
- Works With 2.5-V (LM336) Voltage Reference
- On-Chip Clock Generator
- 0-V to 5-V Analog Input Voltage Range With Single 5-V Supply
- No Zero Adjust Required
- 0.3-Inch Standard Width 20-Pin DIP Package
- 20-Pin Molded Chip Carrier or Small Outline Package
- Operates Ratiometrically or With 5 V_{DC} , 2.5 V_{DC} , or Analog Span Adjusted Voltage Reference
- Key Specifications
 - Resolution: 8 Bits
 - Total Error: $\pm 1/4$ LSB, $\pm 1/2$ LSB and ± 1 LSB
 - Conversion Time: 100 μ s

2 Applications

- Operates With Any 8-Bit μ P Processors or as a Stand-Alone Device
- Interface to Temp Sensors, Voltage Sources, and Transducers

Typical Application Schematic



3 Description

The ADC0801, ADC0802, ADC0803, ADC0804, and ADC0805 devices are CMOS 8-bit successive approximation converters (ADC) that use a differential potentiometric ladder — similar to the 256R products. These converters are designed to allow operation with the NSC800 and INS8080A derivative control bus with Tri-state output latches directly driving the data bus. These ADCs appear like memory locations or I/O ports to the microprocessor and no interfacing logic is needed.

Differential analog voltage inputs allow increasing the common-mode rejection and offsetting the analog zero input voltage value. In addition, the voltage reference input can be adjusted to allow encoding any smaller analog voltage span to the full 8 bits of resolution.

Device Information⁽¹⁾

PART NUMBER	PACKAGE	BODY SIZE (NOM)
ADC0801, ADC0803	PDIP (20)	26.073 mm x 6.604 mm
ADC0802, ADC0804	PDIP (20)	26.073 mm x 6.604 mm
	SOIC (20)	12.80 mm x 7.50 mm

(1) For all available packages, see the orderable addendum at the end of the data sheet.

ADC0801 Specified With $\pm 1/4$ LSB Accuracy

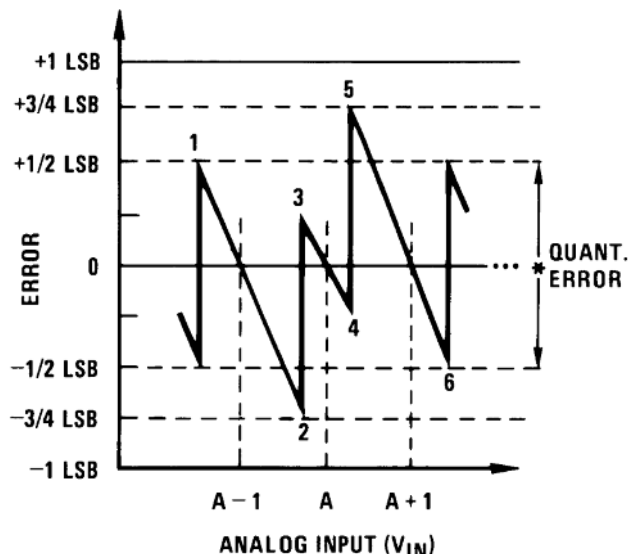


Table of Contents

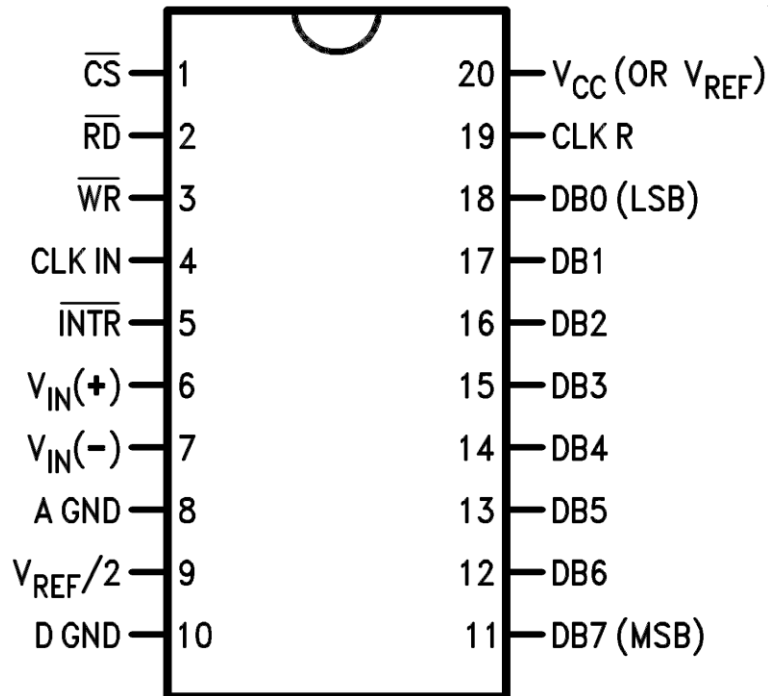
1 Features	1	8.2 Functional Block Diagram	12
2 Applications	1	8.3 Feature Description.....	12
3 Description	1	8.4 Device Functional Modes.....	14
4 Revision History	2	9 Application and Implementation	15
5 Pin Configuration and Functions	3	9.1 Application Information.....	15
6 Specifications	4	9.2 Typical Applications	22
6.1 Absolute Maximum Ratings	4	9.3 System Examples	40
6.2 ESD Ratings.....	4	10 Power Supply Recommendations	48
6.3 Recommended Operating Conditions.....	4	11 Layout	48
6.4 Thermal Information	4	11.1 Layout Guidelines	48
6.5 Operating Ratings	5	12 Device and Documentation Support	49
6.6 Electrical Characteristics.....	5	12.1 Related Links	49
6.7 AC Electrical Characteristics.....	5	12.2 Community Resources.....	49
6.8 Typical Characteristics.....	8	12.3 Trademarks	49
7 Parameter Measurement Information	10	12.4 Electrostatic Discharge Caution.....	49
7.1 Tri-State Test Circuits and Waveforms.....	10	12.5 Glossary	49
8 Detailed Description	11	13 Mechanical, Packaging, and Orderable Information	49
8.1 Overview	11		

4 Revision History

Changes from Revision B (February 2013) to Revision C	Page
• Added <i>Pin Configuration and Functions</i> section, <i>ESD Ratings</i> table, <i>Feature Description</i> section, <i>Device Functional Modes</i> , <i>Application and Implementation</i> section, <i>Power Supply Recommendations</i> section, <i>Layout</i> section, <i>Device and Documentation Support</i> section, and <i>Mechanical, Packaging, and Orderable Information</i> section	1
• Removed <i>Ordering Information</i> table	4

5 Pin Configuration and Functions

NFH and DW Package
20-Pin PDIP and SOIC
Top View



Pin Functions

PIN		I/O	DESCRIPTION
NO.	NAME		
1	CS	I	Chip Select
2	RD	I	Read
3	WR	I	Write
4	CLK IN	I	External Clock input or use internal clock gen with external RC elements
5	INTR	O	Interrupt request
6	V _{IN} (+)	I	Differential analog input+
7	V _{IN} (-)	I	Differential analog input-
8	A GND	I	Analog ground pin
9	V _{REF} /2	I	Reference voltage input for adjustment to correct full scale reading
10	D GND	I	Digital ground pin
11	DB7	O	Data bit 7
12	DB6	O	Data bit 6
13	DB5	O	Data bit 5
14	DB4	O	Data bit 4
15	DB3	O	Data bit 3
16	DB2	O	Data bit 2
17	DB1	O	Data bit 1
18	DB0 (LSB)	O	Data bit 0
19	CLK R	I	RC timing resistor input pin for internal clock gen
20	V _{CC} (or V _{REF})	I	+5V supply voltage, also upper reference input to the ladder

6 Specifications

6.1 Absolute Maximum Ratings

 over operating free-air temperature range (unless otherwise noted)⁽¹⁾⁽²⁾

		MIN	MAX	UNIT
Supply voltage (V_{CC}) ⁽³⁾			6.5	V
Voltage	Logic control inputs	-0.3	18	V
	At other input and outputs	-0.3	($V_{CC} + 0.3$)	
Lead Temperature (Soldering, 10 seconds)	Dual-In-Line Package (plastic)		260	°C
	Dual-In-Line Package (ceramic)		300	
	Surface Mount Package Vapor Phase (60 seconds)		215	
	Infrared (15 seconds)		220	
Storage Temperature		-65	150	
Package Dissipation at $T_A = 25^\circ\text{C}$			875	mW

- (1) Stresses beyond those listed under *Absolute Maximum Ratings* may cause permanent damage to the device. These are stress ratings only, which do not imply functional operation of the device at these or any other conditions beyond those indicated under *Recommended Operating Conditions*. Exposure to absolute-maximum-rated conditions for extended periods may affect device reliability.
- (2) If Military/Aerospace specified devices are required, contact the Sales Office/Distributors for availability and specifications.
- (3) A Zener diode exists, internally, from V_{CC} to GND and has a typical breakdown voltage of $7 V_{DC}$.

6.2 ESD Ratings

			VALUE	UNIT
$V_{(ESD)}$	Electrostatic discharge	Human body model (HBM), per ANSI/ESDA/JEDEC JS-001 ⁽¹⁾	±800	V

- (1) JEDEC document JEP155 states that 500-V HBM allows safe manufacturing with a standard ESD control process.

6.3 Recommended Operating Conditions

over operating free-air temperature range (unless otherwise noted)

	MIN	NOM	MAX	UNIT
V_{CC}	4.5	5	5.5	V
Analog Input Voltage	GND – 0.05		$V_{CC} + 0.05$	V_{DC}

6.4 Thermal Information

THERMAL METRIC ⁽¹⁾		ADC080x	ADC0802, ADC0804	UNIT
		NFH (PDIP)	DW (SOIC)	
		20 PINS	20 PINS	
$R_{\theta JA}$	Junction-to-ambient thermal resistance	38.5	63.8	°C/W
$R_{\theta JC(top)}$	Junction-to-case (top) thermal resistance	23.4	27.2	°C/W
$R_{\theta JB}$	Junction-to-board thermal resistance	19.5	31.8	°C/W
Ψ_{JT}	Junction-to-top characterization parameter	8.7	5.7	°C/W
Ψ_{JB}	Junction-to-board characterization parameter	19.4	31.3	°C/W
$R_{\theta JC(bot)}$	Junction-to-case (bottom) thermal resistance	—	—	°C/W

- (1) For more information about traditional and new thermal metrics, see the *Semiconductor and IC Package Thermal Metrics* application report, [SPRA953](#).

6.5 Operating Ratings

over operating free-air temperature range (unless otherwise noted)⁽¹⁾⁽²⁾.

		MIN	MAX	UNIT
Temperature	ADC0804LCJ	-40	85	°C
	ADC0801/02/03/05LCN	-40	85	
	ADC0804LCN	0	70	
	ADC0802/04LCWM	0	70	
Range of V _{CC}		4.5	6.3	V _{DC}

- (1) *Absolute Maximum Ratings* indicate limits beyond which damage to the device may occur. DC and AC electrical specifications do not apply when operating the device beyond its specified operating conditions.
- (2) All voltages are measured with respect to GND, unless otherwise specified. The separate A GND point should always be wired to the D GND.

6.6 Electrical Characteristics

The following specifications apply for V_{CC} = 5 V_{DC}, T_{MIN} ≤ T_A ≤ T_{MAX} and f_{CLK} = 640 kHz (unless otherwise specified).

PARAMETER	TEST CONDITIONS	MIN	TYP	MAX	UNIT
ADC0801: Total Adjusted Error ⁽¹⁾	With Full-Scale Adj. (See Full-Scale)			±1/4	LSB
ADC0802: Total Unadjusted Error ⁽¹⁾	V _{REF/2} =2.500 V _{DC}			±1/2	
ADC0803: Total Adjusted Error ⁽¹⁾	With Full-Scale Adj. (See Full-Scale)			±1/2	
ADC0804: Total Unadjusted Error ⁽¹⁾	V _{REF/2} =2.500 VDC			±1	
ADC0805: Total Unadjusted Error ⁽¹⁾	V _{REF/2} -No Connection			±1	
V _{REF/2} Input Resistance (Pin 9)	ADC0801/02/03/05	2.5	8		kΩ
	ADC0804 ⁽²⁾	0.75	1.1		
Analog Input Voltage Range	V(+) or V(-) ⁽³⁾	GND-0.05		V _{CC} +0.05	V _{DC}
DC Common-Mode Error	Over Analog Input Voltage Range		±1/16	±1/8	LSB
Power Supply Sensitivity	V _{CC} =5 V _{DC} ±10% Over Allowed V _{IN} (+) and V _{IN} (-) Voltage Range ⁽³⁾		±1/16	±1/8	LSB

- (1) None of these ADCs requires a zero adjust (see [Zero Error](#)). To obtain zero code at other analog input voltages see [Errors and Reference Voltage Adjustments](#).
- (2) The V_{REF/2} pin is the center point of a two-resistor divider connected from V_{CC} to ground. In all versions of the ADC0801, ADC0802, ADC0803, and ADC0805, and in the ADC0804LCJ, each resistor is typically 16 kΩ. In all versions of the ADC0804 except the ADC0804LCJ, each resistor is typically 2.2 kΩ.
- (3) For V_{IN}(-) ≥ V_{IN}(+) the digital output code will be 0000 0000. Two on-chip diodes are tied to each analog input (see block diagram) which will forward conduct for analog input voltages one diode drop below ground or one diode drop greater than the V_{CC} supply. Be careful, during testing at low V_{CC} levels (4.5V), as high level analog inputs (5V) can cause this input diode to conduct—especially at elevated temperatures, and cause errors for analog inputs near full-scale. The spec allows 50 mV forward bias of either diode. This means that as long as the analog V_{IN} does not exceed the supply voltage by more than 50 mV, the output code will be correct. To achieve an absolute 0 V_{DC} to 5 V_{DC} input voltage range will therefore require a minimum supply voltage of 4.950 V_{DC} over temperature variations, initial tolerance and loading.

6.7 AC Electrical Characteristics

The following specifications apply for V_{CC}=5 V_{DC} and T_{MIN} ≤ T_A ≤ T_{MAX} (unless otherwise specified)

PARAMETER	TEST CONDITIONS	MIN	TYP	MAX	UNIT
T _C Conversion Time	f _{CLK} = 640 kHz ⁽¹⁾	103		114	μs
	See ⁽²⁾⁽¹⁾	66		73	1/f _{CLK}
f _{CLK} Clock Frequency	V _{CC} = 5V ⁽²⁾	100	640	1460	kHz
		Clock Duty Cycle		40%	
CR Conversion Rate in Free-Running Mode	INTR tied to \overline{WR} with $\overline{CS} = 0$ VDC, f _{CLK} = 640 kHz	8770		9708	conv/s

- (1) Accuracy is specified at f_{CLK} = 640 kHz. At higher clock frequencies accuracy can degrade. For lower clock frequencies, the duty cycle limits can be extended so long as the minimum clock high time interval or minimum clock low time interval is no less than 275 ns.
- (2) With an asynchronous start pulse, up to 8 clock periods may be required before the internal clock phases are proper to start the conversion process. The start request is internally latched. Refer to [Detailed Description](#).

AC Electrical Characteristics (continued)

 The following specifications apply for $V_{CC}=5 V_{DC}$ and $T_{MIN} \leq T_A \leq T_{MAX}$ (unless otherwise specified)

PARAMETER		TEST CONDITIONS	MIN	TYP	MAX	UNIT	
$t_{W(\overline{WR})L}$	Width of \overline{WR} Input (Start Pulse Width)	$\overline{CS} = 0$ VDC ⁽³⁾	100			ns	
tACC	Access Time (Delay from Falling Edge of RD to Output Data Valid)	$C_L = 100$ pF		135	200		
t1H, t0H	Tri-State Control (Delay from Rising Edge of \overline{RD} to Hi-Z State)	$C_L = 10$ pF, $R_L = 10k$ (See Tri-State Test Circuits and Waveforms)		125	200		
t_{WI}, t_{RI}	Delay from Falling Edge of \overline{WR} or \overline{RD} to Reset of INTR			300	450		
C_{IN}	Input Capacitance of Logic Control Inputs			5	7.5	pF	
C_{OUT}	Tri-State Output Capacitance (Data Buffers)			5	7.5		
CONTROL INPUTS [Note: CLK IN (Pin 4) is the input of a Schmitt trigger circuit and is therefore specified separately]							
$V_{IN}(1)$	Logical "1" Input Voltage (Except Pin 4 CLK IN)	$V_{CC} = 5.25$ VDC	2		15	V_{DC}	
$V_{IN}(0)$	Logical "0" Input Voltage (Except Pin 4 CLK IN)	$V_{CC} = 4.75$ VDC			0.8		
$I_{IN}(1)$	Logical "1" Input Current (All Inputs)	$V_{IN} = 5$ VDC		0.005	1	μA_{DC}	
$I_{IN}(0)$	Logical "0" Input Current (All Inputs)	$V_{IN} = 0$ VDC	-1	-0.005			
CLOCK IN AND CLOCK R							
V_{T+}	CLK IN (Pin 4) Positive Going Threshold Voltage		2.7	3.1	3.5	V_{DC}	
V_{T-}	CLK IN (Pin 4) Negative Going Threshold Voltage		1.5	1.8	2.1		
V_H	CLK IN (Pin 4) Hysteresis (V_{T+})–(V_{T-})		0.6	1.3	2		
$V_{OUT}(0)$	Logical "0" CLK R Output Voltage	$I_O = 360 \mu A$, $V_{CC} = 4.75$ VDC			0.4		
$V_{OUT}(1)$	Logical "1" CLK R Output Voltage	$I_O = -360 \mu A$, $V_{CC} = 4.75$ VDC	2.4				
DATA OUTPUTS AND INTR							
$V_{OUT}(0)$	Logical "0" Output Voltage	Data Outputs	$I_{OUT} = 1.6$ mA, $V_{CC} = 4.75$ VDC		0.4	V_{DC}	
		\overline{INTR} Output	$I_{OUT} = 1.0$ mA, $V_{CC} = 4.75$ VDC		0.4		
$V_{OUT}(1)$	Logical "1" Output Voltage	$I_O = -360 \mu A$, $V_{CC} = 4.75$ VDC		2.4			
		$I_O = -10 \mu A$, $V_{CC} = 4.75$ VDC		4.5			
I_{OUT}	Tri-State Disabled Output Leakage (All Data Buffers)	$V_{OUT} = 0$ VDC		-3			
		$V_{OUT} = 5$ VDC			3		
I_{SOURCE}		V_{OUT} Short to GND, $T_A = 25^\circ C$	4.5	6		mA_{DC}	
I_{SINK}		V_{OUT} Short to V_{CC} , $T_A = 25^\circ C$	9	16			
POWER SUPPLY							
I_{CC}	Supply Current (Includes Ladder Current)	ADC0801/02/03/04LCJ/05	$f_{CLK} = 640$ kHz, $V_{REF}/2 = NC$, $T_A = 25^\circ C$ and $CS = 5$ V		1.1	1.8	mA
		ADC0804LCN/LCWM			1.9	2.5	

(3) The \overline{CS} input is assumed to bracket the \overline{WR} strobe input and therefore timing is dependent on the \overline{WR} pulse width. An arbitrarily wide pulse width will hold the converter in a reset mode and the start of conversion is initiated by the low to high transition of the \overline{WR} pulse.

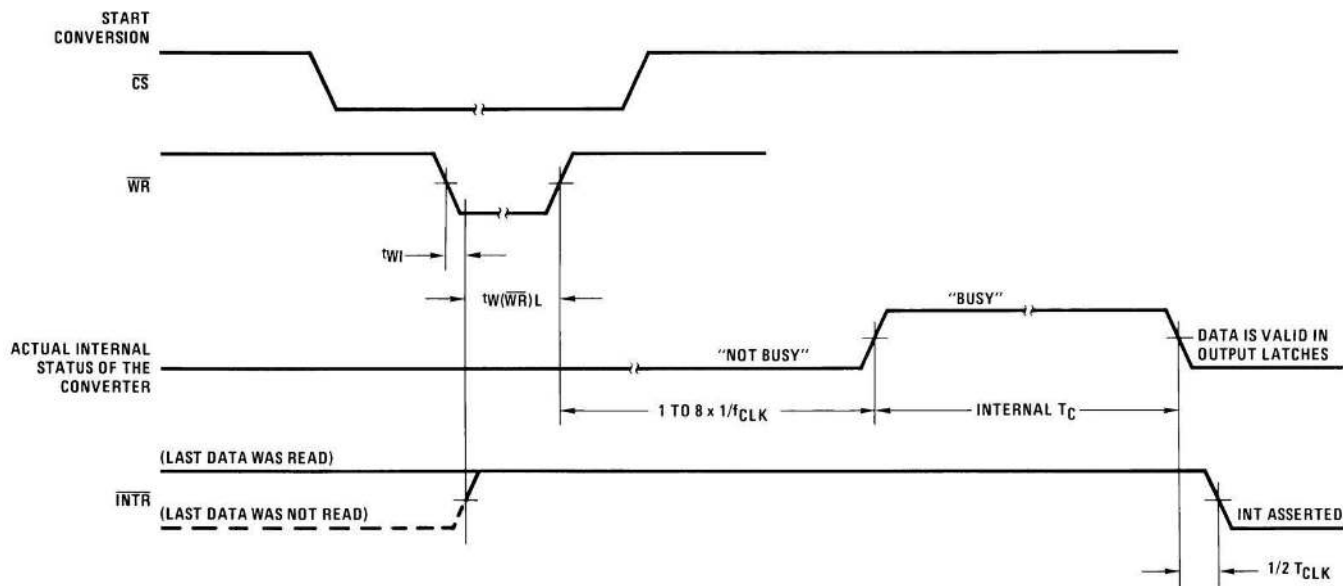
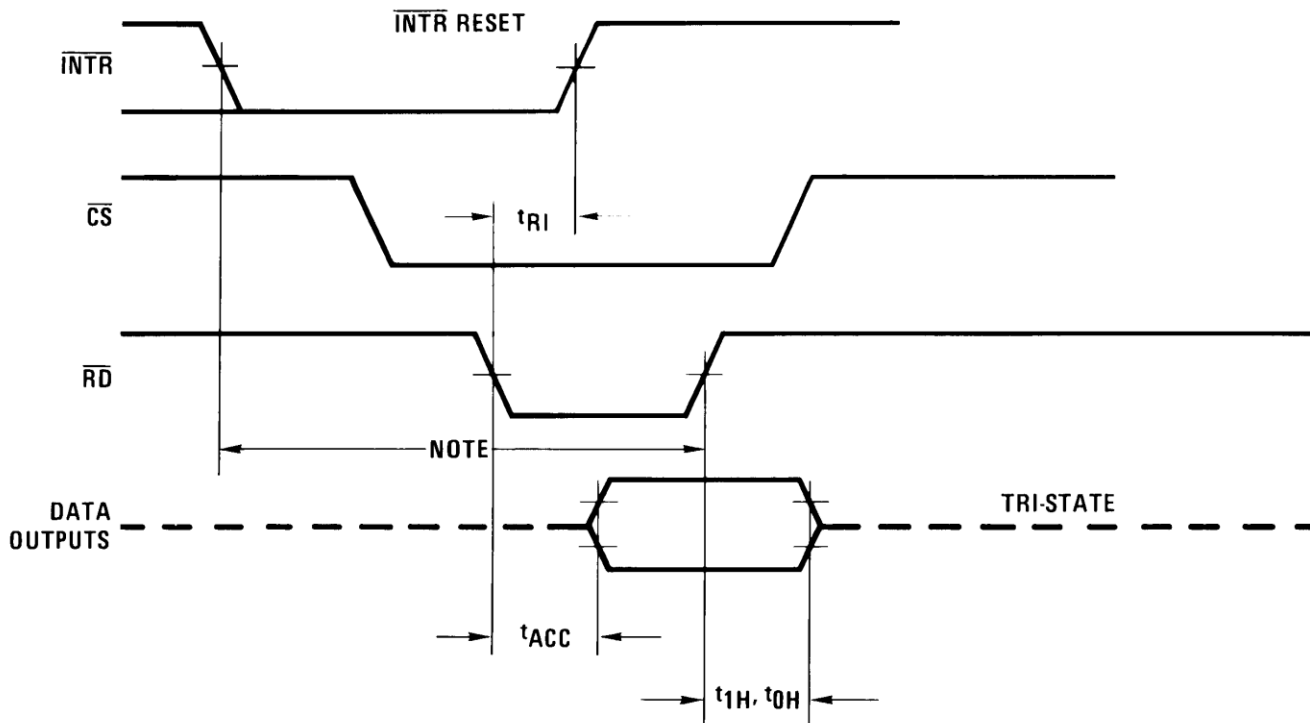


Figure 1. Start Conversion



Note: Read strobe must occur 8 clock periods ($8/f_{CLK}$) after assertion of interrupt to specify reset of \overline{INTR} .

Figure 2. Output Enable and Reset With \overline{INTR}

6.8 Typical Characteristics

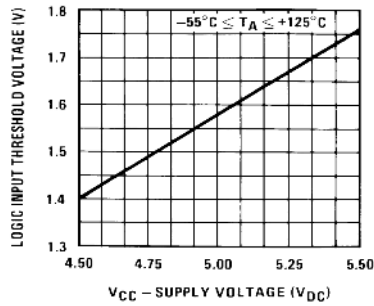


Figure 3. Logic Input Threshold Voltage vs Supply Voltage

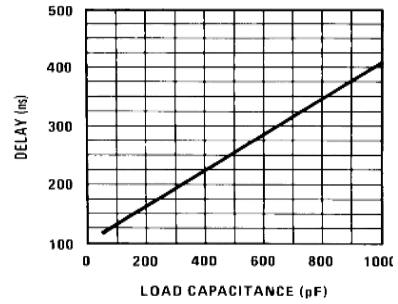


Figure 4. Delay From Falling Edge of \overline{RD} to Output Data Valid vs Load Capacitance

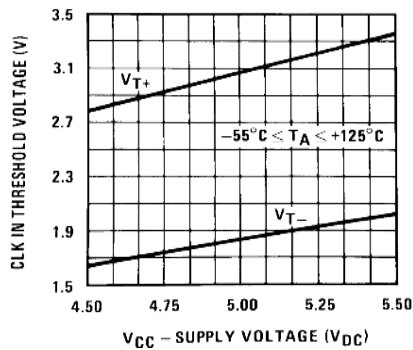


Figure 5. CLK IN Schmitt Trip Levels vs Supply Voltage

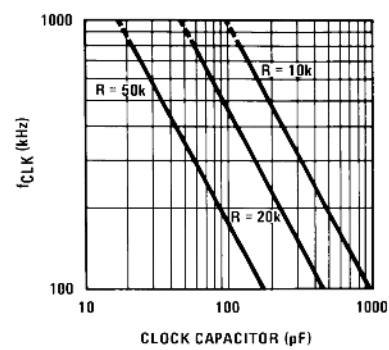


Figure 6. f_{CLK} vs Clock Capacitor

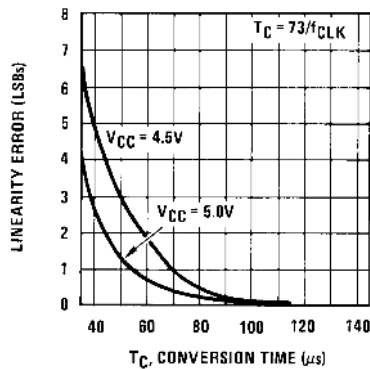


Figure 7. Full-Scale Error vs Conversion Time

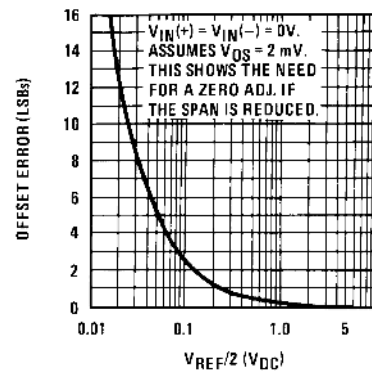


Figure 8. Effect of Unadjusted Offset Error vs $V_{REF}/2$ Voltage

Typical Characteristics (continued)

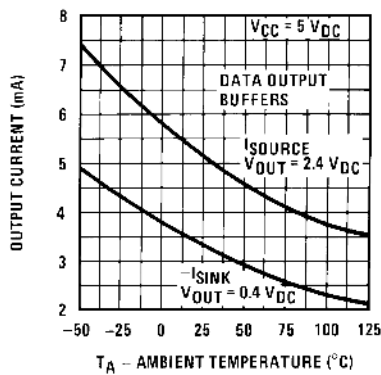


Figure 9. Output Current vs Temperature

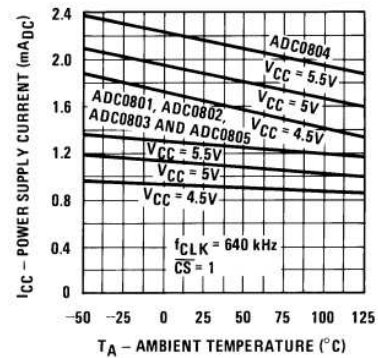


Figure 10. Power Supply Current vs Temperature⁽¹⁾

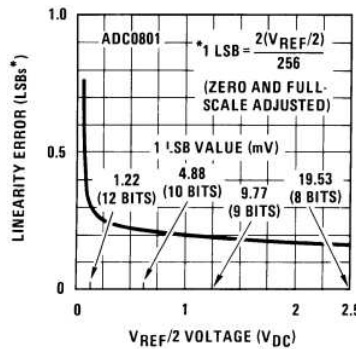


Figure 11. Linearity Error at Low $V_{REF/2}$ Voltages

(1) The $V_{REF/2}$ pin is the center point of a two-resistor divider connected from V_{CC} to ground. In all versions of the ADC0801, ADC0802, ADC0803, and ADC0805, and in the ADC0804LCJ, each resistor is typically 16 kΩ. In all versions of the ADC0804 except the ADC0804LCJ, each resistor is typically 2.2 kΩ.

7 Parameter Measurement Information

7.1 Tri-State Test Circuits and Waveforms

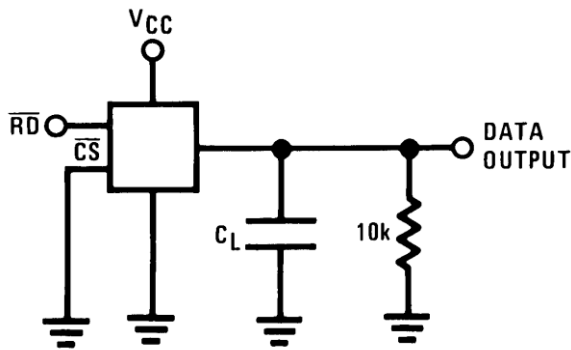

 $C_L = 10 \text{ pF}$

Figure 12. RD to Data Output Falling Edge Test Load Condition

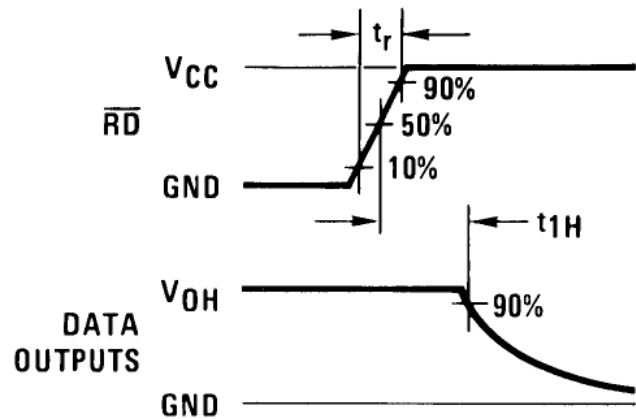


Figure 13. RD to Data Output Falling Edge Test Timing

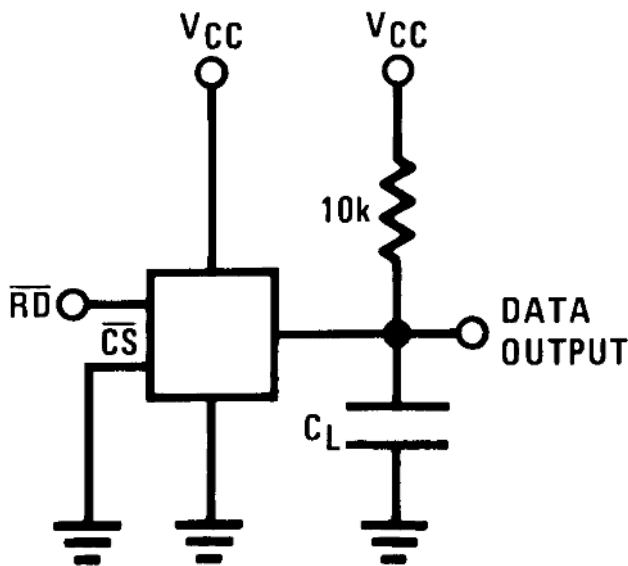

 $C_L = 10 \text{ pF}$

Figure 14. RD to Data Output Rising Edge Test Load Condition

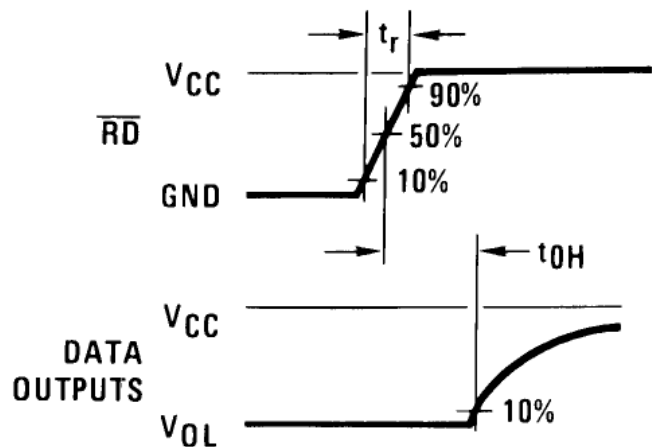


Figure 15. RD to Data Output Rising Edge Test Timing

8 Detailed Description

8.1 Overview

The ADC0801 series are versatile 8-Bit μ P compatible general purpose ADC converters operate on single 5-V supply. These devices are treated as a memory location or I/O port to a micro-processor system without additional interface logic. The outputs are Tri-state latched which facilitate interfacing to micro-processor control bus. The converter is designed with a differential potentiometric ladder, a circuit equivalent of the 256R network. It contains analog switches sequenced by successive approximation logic. A functional diagram of the ADC converter is shown in [Functional Block Diagram](#). All of the package pinouts are shown and the major logic control paths are drawn in heavier weight lines. The differential analog voltage input has good common mode-rejection and permits offsetting the analog zero-input voltage value. Moreover, the input reference voltage can be adjusted to allow encoding small analog voltage span to the full 8-bits resolution. To ensure start-up under all possible conditions, an external \overline{WR} pulse is required during the first power-up cycle.

Using a SAR logic the most significant bit is tested first and after 8 comparisons (64 clock cycles) a digital 8-bit binary code (1111 1111 = full-scale) is transferred to an output latch and then an interrupt is asserted (\overline{INTR} makes a high-to-low transition). A conversion in process can be interrupted by issuing a second start command. The device may be operated in the free-running mode by connecting \overline{INTR} to the \overline{WR} input with $\overline{CS}=0$.

On the high-to-low transition of the \overline{WR} input the internal SAR latches and the shift register stages are reset. As long as the \overline{CS} input and \overline{WR} input remain low, the ADC will remain in a reset state. Conversion will start from 1 to 8 clock periods after at least one of these inputs makes a low-to-high transition.

The converter is started by having \overline{CS} and \overline{WR} simultaneously low. This sets the start flip-flop (F/F) and the resulting "1" level resets the 8-bit shift register, resets the Interrupt (\overline{INTR}) F/F and inputs a "1" to the D flop, F/F1, which is at the input end of the 8-bit shift register. Internal clock signals then transfer this "1" to the Q output of F/F1. The AND gate, G1, combines this "1" output with a clock signal to provide a reset signal to the start F/F. If the set signal is no longer present (either \overline{WR} or \overline{CS} is a "1") the start F/F is reset and the 8-bit shift register then can have the "1" clocked in, which starts the conversion process. If the set signal were to still be present, this reset pulse would have no effect (both outputs of the start F/F would momentarily be at a "1" level) and the 8-bit shift register would continue to be held in the reset mode. This logic therefore allows for wide \overline{CS} and \overline{WR} signals and the converter will start after at least one of these signals returns high and the internal clocks again provide a reset signal for the start F/F.

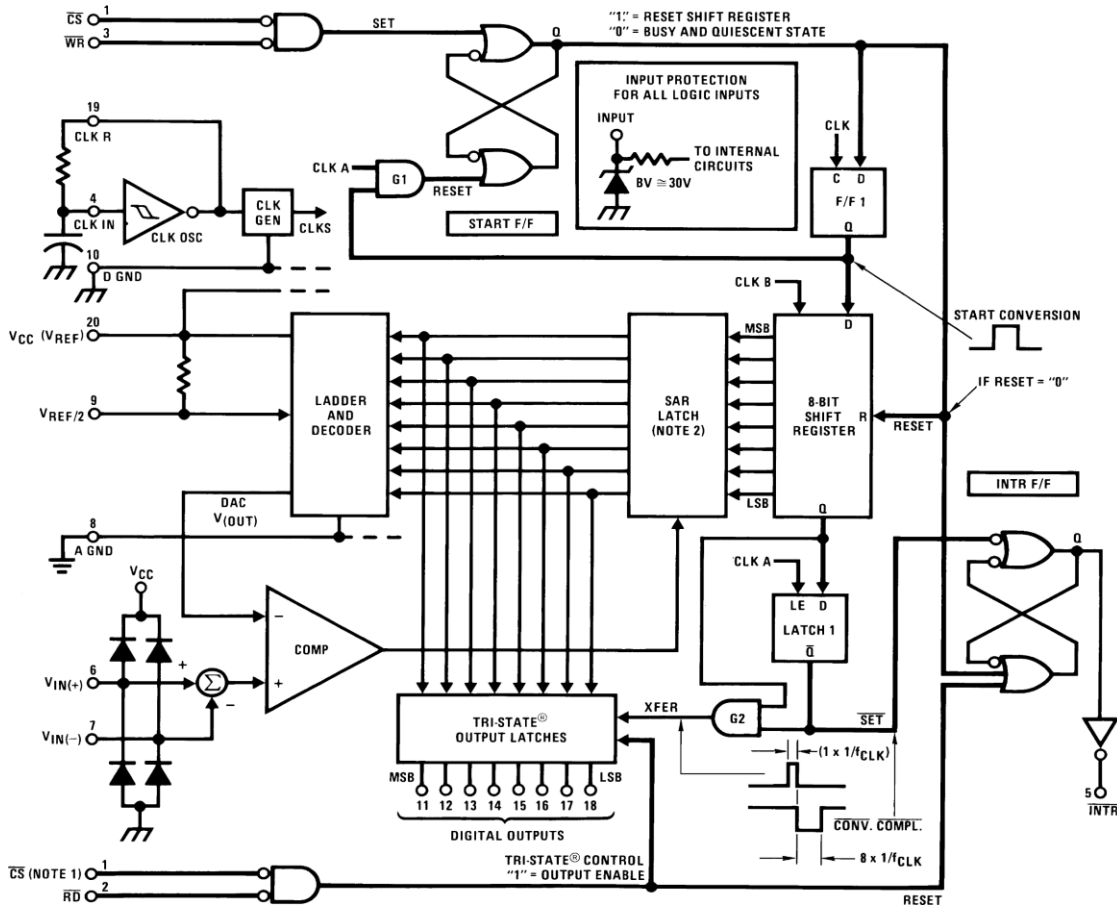
After the "1" is clocked through the 8-bit shift register (which completes the SAR search) it appears as the input to the D-type latch, LATCH 1. As soon as this "1" is output from the shift register, the AND gate, G2, causes the new digital word to transfer to the Tri-state output latches. When LATCH 1 is subsequently enabled, the \overline{Q} output makes a high-to-low transition which causes the \overline{INTR} F/F to set. An inverting buffer then supplies the \overline{INTR} input signal.

Note this \overline{SET} control of the \overline{INTR} F/F remains low for 8 of the external clock periods (as the internal clocks run at 1/8 of the frequency of the external clock). If the data output is continuously enabled (\overline{CS} and \overline{RD} both held low), the \overline{INTR} output will still signal the end of conversion (by a high-to-low transition), because the \overline{SET} input can control the \overline{Q} output of the \overline{INTR} F/F even though the RESET input is constantly at a M "1M" level in this operating mode. This \overline{INTR} output will therefore stay low for the duration of the \overline{SET} signal, which is 8 periods of the external clock frequency (assuming the ADC is not started during this interval).

When operating in the free-running or continuous conversion mode (\overline{INTR} pin tied to \overline{WR} and \overline{CS} wired low – see [Continuous Conversions](#)), the START F/F is SET by the high-to-low transition of the \overline{INTR} signal. This resets the SHIFT REGISTER which causes the input to the D-type latch, LATCH 1, to go low. As the latch enable input is still present, the \overline{Q} output will go high, which then allows the \overline{INTR} F/F to be RESET. This reduces the width of the resulting \overline{INTR} output pulse to only a few propagation delays (approximately 300 ns).

When data is to be read, the combination of both \overline{CS} and \overline{RD} being low will cause the \overline{INTR} F/F to be reset and the Tri-state output latches will be enabled to provide the 8-bit digital outputs.

8.2 Functional Block Diagram



- (1) \overline{CS} shown twice for clarity.
- (2) SAR = Successive Approximation Register.

8.3 Feature Description

8.3.1 Understanding ADC Error Specs

A perfect ADC transfer characteristic (staircase waveform) is shown in [Figure 16](#) and [Figure 17](#). The horizontal scale is analog input voltage and the particular points labeled are in steps of 1 LSB (19.53 mV with 2.5V tied to the VREF/2 pin). The digital output codes that correspond to these inputs are shown as D-1, D, and D+1. For the perfect ADC, not only will center-value (A-1, A, A+1,) analog inputs produce the correct output digital codes, but also each riser (the transitions between adjacent output codes) will be located $\pm 1/2$ LSB away from each center-value. As shown, the risers are ideal and have no width. Correct digital output codes will be provided for a range of analog input voltages that extend $\pm 1/2$ LSB from the ideal center-values. Each tread (the range of analog input voltage that provides the same digital output code) is therefore 1 LSB wide.

[Figure 19](#) shows a worst case error plot for the ADC0801. All center-valued inputs are guaranteed to produce the correct output codes and the adjacent risers are specified to be no closer to the center-value points than $\pm 1/4$ LSB. In other words, if we apply an analog input equal to the center-value $\pm 1/4$ LSB, we guarantee that the ADC will produce the correct digital code. The maximum range of the position of the code transition is indicated by the horizontal arrow and it is specified to be no more than $1/2$ LSB.

The error curve of [Figure 21](#) shows a worst case error plot for the ADC0802. Here we guarantee that if we apply an analog input equal to the LSB analog voltage center-value the ADC will produce the correct digital code.

Feature Description (continued)

Next to each transfer function is shown the corresponding error plot. Many people may be more familiar with error plots than transfer functions. The analog input voltage to the ADC is provided by either a linear ramp or by the discrete output steps of a high resolution DAC. Notice that the error is continuously displayed and includes the quantization uncertainty of the ADC. For example the error at point 1 of Figure 21 is +1/2 LSB because the digital code appeared 1/2 LSB in advance of the center-value of the tread. The error plots always have a constant negative slope and the abrupt up-side steps are always 1 LSB in magnitude.

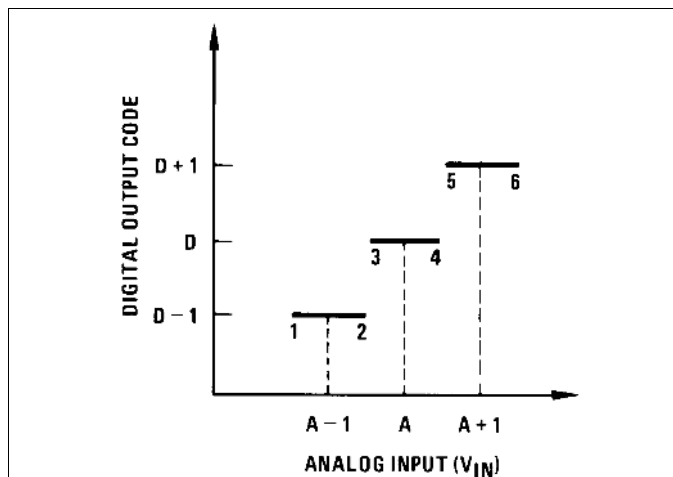


Figure 16. Transfer Function of Analog Input vs Digital Output Code in Ideal ADC

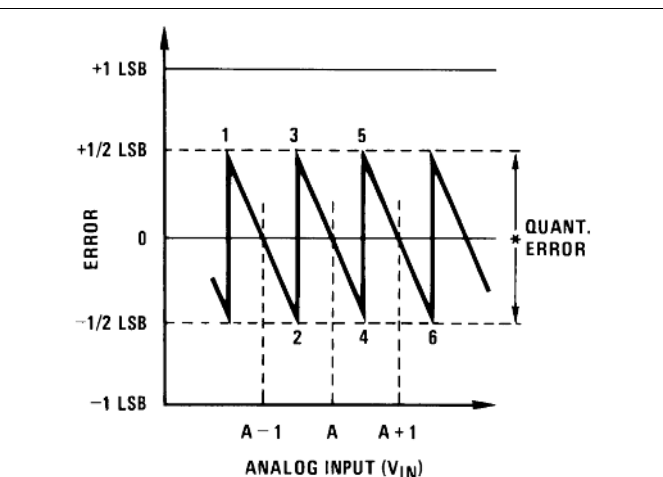


Figure 17. Clarifying the Error Specs of an ADC Converter Accuracy=±0 LSB: A Perfect ADC

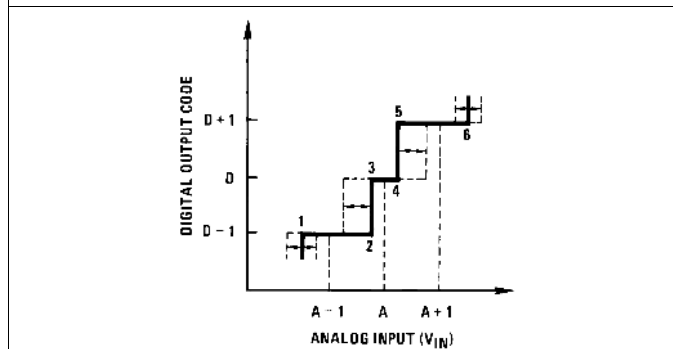


Figure 18. Transfer Function of Analog Input vs Digital Output Code for ±1/4 LSB Accuracy ADC

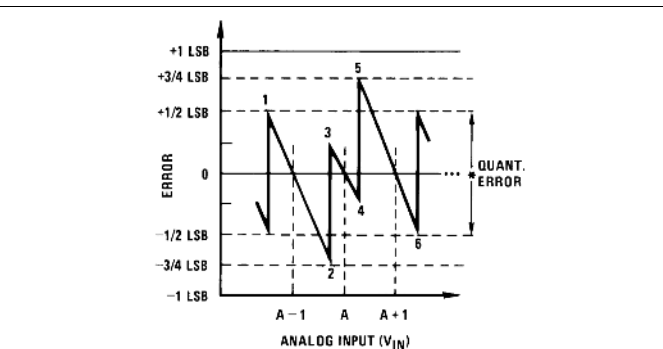


Figure 19. Clarifying the Error Specs of an ADC Converter Accuracy =±1/4 LSB

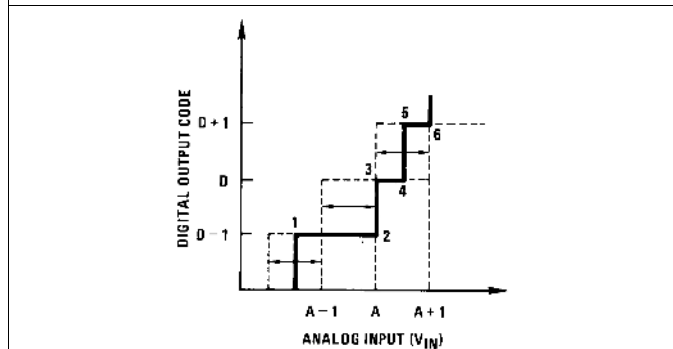


Figure 20. Transfer Function of Analog Input vs Digital Output Code for ±1/2 LSB Accuracy ADC

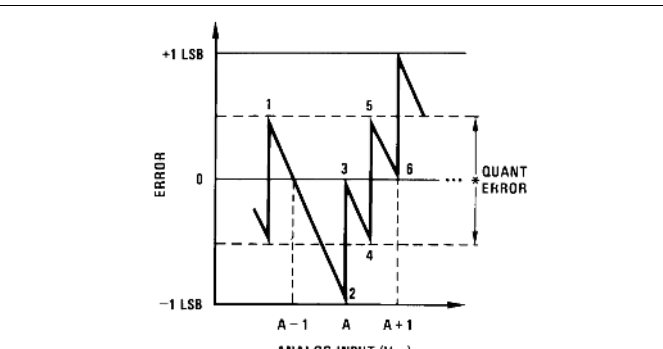


Figure 21. Clarifying the Error Specs of an ADC Converter Accuracy = ±1/2 LSB

Feature Description (continued)

8.3.2 Digital Control Inputs

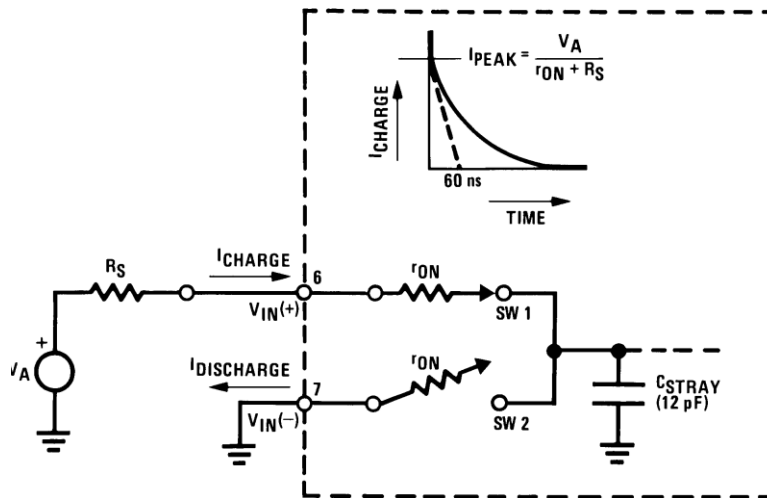
The digital control inputs (\overline{CS} , \overline{RD} , and \overline{WR}) meet standard TLL logic voltage levels. These signals have been renamed when compared to the standard ADC Start and Output Enable labels. In addition, these inputs are active low to allow an easy interface to microprocessor control busses. For non-microprocessor based applications, the \overline{CS} input (pin 1) can be grounded and the standard ADC Start function is obtained by an active low pulse applied at the \overline{WR} input (pin 3) and the Output Enable function is caused by an active low pull at the \overline{RD} input (pin 2).

8.4 Device Functional Modes

8.4.1 Analog Input Modes

8.4.1.1 Normal Mode

Due to the internal switching action, displacement currents will flow at the analog inputs. This is due to on-chip stray capacitance to ground as shown in Figure 22.



$$r_{ON} \text{ of SW 1 and SW } 2.5 \text{ k}\Omega$$

$$t = r_{ON} C_{STRAY} \times 5 \text{ k}\Omega \times 12 \text{ pF} = 60 \text{ ns}$$

Figure 22. Analog Input Impedance

The voltage on this capacitance is switched and will result in currents entering the $V_{IN}(+)$ input pin and leaving the $V_{IN}(-)$ input which will depend on the analog differential input voltage levels. These current transients occur at the leading edge of the internal clocks. They rapidly decay and do not cause errors as the on-chip comparator is strobed at the end of the clock period.

8.4.1.2 Fault Mode

If the voltage source applied to the $V_{IN}(+)$ or $V_{IN}(-)$ pin exceeds the allowed operating range of $V_{CC}+50$ mV, large input currents can flow through a parasitic diode to the V_{CC} pin. If these currents can exceed the 1 mA max allowed spec, an external diode (1N914) should be added to bypass this current to the V_{CC} pin (with the current bypassed with this diode, the voltage at the $V_{IN}(+)$ pin can exceed the V_{CC} voltage by the forward voltage of this diode).

9 Application and Implementation

NOTE

Information in the following applications sections is not part of the TI component specification, and TI does not warrant its accuracy or completeness. TI's customers are responsible for determining suitability of components for their purposes. Customers should validate and test their design implementation to confirm system functionality.

9.1 Application Information

The following sections give example circuits and suggestions for using the ADC080X in typical application situation with a typical 8-bit micro-processor.

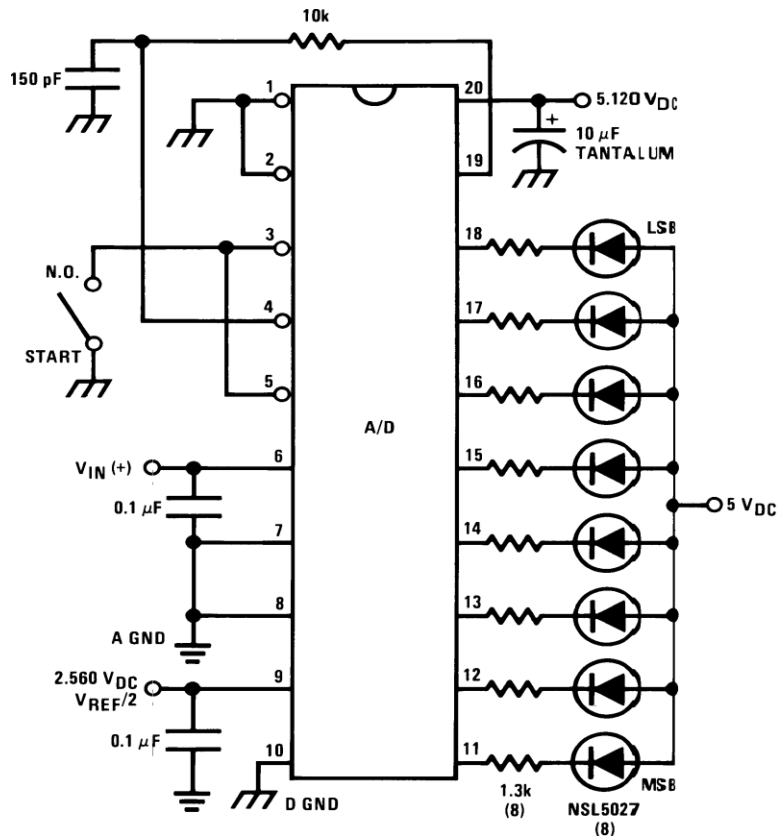
9.1.1 Testing the ADC Converter

There are many degrees of complexity associated with testing an ADC converter. One of the simplest tests is to apply a known analog input voltage to the converter and use LEDs to display the resulting digital output code as shown in [Figure 23](#).

For ease of testing, the $V_{REF/2}$ (pin 9) should be supplied with $2.560 V_{DC}$ and a V_{CC} supply voltage of $5.12 V_{DC}$ should be used. This provides an LSB value of 20 mV.

If a full-scale adjustment is to be made, an analog input voltage of $5.090 V_{DC}$ ($5.120 - 1/2$ LSB) should be applied to the $V_{IN(+)}$ pin with the $V_{IN(-)}$ pin grounded. The value of the $V_{REF/2}$ input voltage should then be adjusted until the digital output code is just changing from 1111 1110 to 1111 1111. This value of $V_{REF/2}$ should then be used for all the tests.

The digital output LED display can be decoded by dividing the 8 bits into 2 hex characters, the 4 most significant (MS) and the 4 least significant (LS). [Table 1](#) shows the fractional binary equivalent of these two 4-bit groups. By adding the voltages obtained from the "VM" and "VLS" columns in [Table 1](#), the nominal value of the digital display (when $V_{REF/2} = 2.560V$) can be determined. For example, for an output LED display of 1011 0110 or B6 (in hex), the voltage values from the table are $3.520 + 0.120$ or $3.640 V_{DC}$. These voltage values represent the center-values of a perfect ADC converter. The effects of quantization error have to be accounted for in the interpretation of the test results.

Application Information (continued)

Figure 23. Basic ADC Tester

For a higher speed test system, or to obtain plotted data, a digital-to-analog converter is needed for the test set-up. An accurate 10-bit DAC can serve as the precision voltage source for the ADC. Errors of the ADC under test can be expressed as either analog voltages or differences in 2 digital words.

A basic ADC tester that uses a DAC and provides the error as an analog output voltage is shown in [Figure 35](#). The 2 op amps can be eliminated if a lab DVM with a numerical subtraction feature is available to read the difference voltage, "A-C", directly. The analog input voltage can be supplied by a low frequency ramp generator and an X-Y plotter can be used to provide analog error (Y axis) versus analog input (X axis).

For operation with a microprocessor or a computer-based test system, it is more convenient to present the errors digitally. This can be done with the circuit of [Figure 25](#), where the output code transitions can be detected as the 10-bit DAC is incremented. This provides 1/4 LSB steps for the 8-bit ADC under test. If the results of this test are automatically plotted with the analog input on the X axis and the error (in LSB's) as the Y axis, a useful transfer function of the ADC under test results. For acceptance testing, the plot is not necessary and the testing speed can be increased by establishing internal limits on the allowed error for each code.

9.1.2 Microprocessor Interfacing

To discuss the interface with 8080A and 6800 microprocessors, a common sample subroutine structure is used. The microprocessor starts the ADC, reads and stores the results of 16 successive conversions, then returns to the user's program. The 16 data bytes are stored in 16 successive memory locations. All Data and Addresses will be given in hexadecimal form. Software and hardware details are provided separately for each type of microprocessor.

Application Information (continued)

9.1.2.1 Interfacing 8080 Microprocessor Derivatives (8048, 8085)

This converter has been designed to directly interface with derivatives of the 8080 microprocessor. The ADC can be mapped into memory space (using standard memory address decoding for CS and the MEMR and MEMW strobes) or it can be controlled as an I/O device by using the I/O R and I/O W strobes and decoding the address bits A0 → A7 (or address bits A8 → A15 as they will contain the same 8-bit address information) to obtain the CS input. Using the I/O space provides 256 additional addresses and may allow a simpler 8-bit address decoder but the data can only be input to the accumulator. To make use of the additional memory reference instructions, the ADC should be mapped into memory space. An example of an ADC in I/O space is shown in Figure 26.

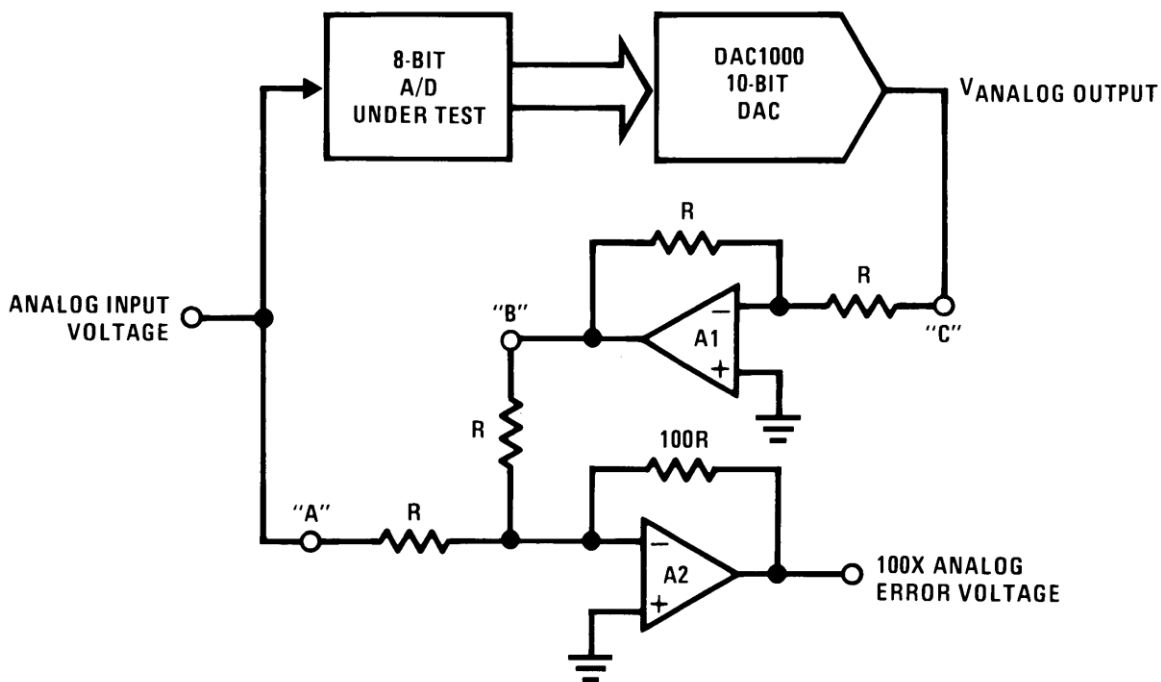


Figure 24. ADC Tester with Analog Error Output

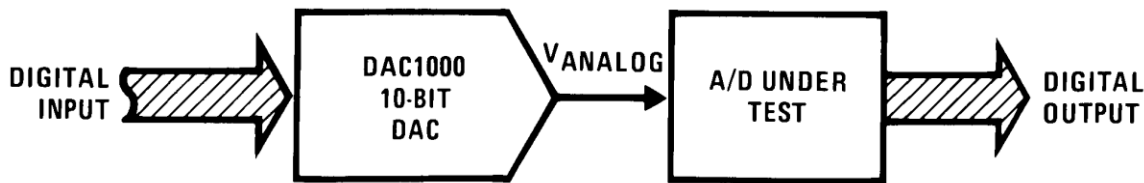


Figure 25. Basic "Digital" ADC Tester

Table 1. Decoding the Digital Output LEDs

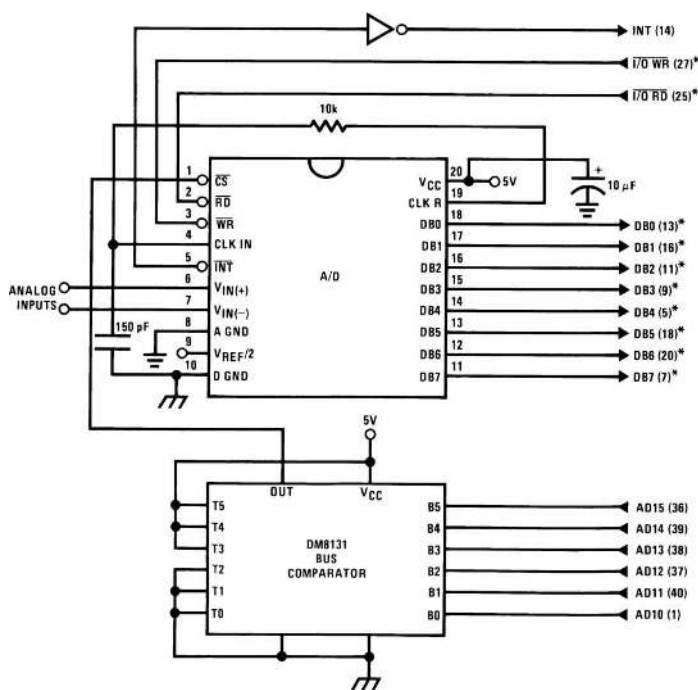
HEX	BINARY	FRACTIONAL BINARY VALUE FOR						OUTPUT VOLTAGE CENTER VALUES WITH $V_{REF}/2=2.560 V_{DC}$		
		MS GROUP			LS GROUP			VMS GROUP ⁽¹⁾	VLS GROUP ⁽¹⁾	
F	1 1 1 1				15/16			15/256	4.800	0.300
E	1 1 1 0		7/8				7/128		4.480	0.280
D	1 1 0 1				13/16			13/256	4.160	0.260
C	1 1 0 0		3/4				3/64		3.840	0.240
B	1 0 1 1				11/16			11/256	3.520	0.220

(1) Display Output=VMS Group + VLS Group

Application Information (continued)

Table 1. Decoding the Digital Output LEDs (continued)

HEX	BINARY				FRACTIONAL BINARY VALUE FOR								OUTPUT VOLTAGE CENTER VALUES WITH $V_{REF/2}=2.560 V_{DC}$	
					MS GROUP				LS GROUP				VMS GROUP ⁽¹⁾	VLS GROUP ⁽¹⁾
A	1	0	1	0			5/8				5/128		3.200	0.200
9	1	0	0	1				9/16				9/256	2.880	0.180
8	1	0	0	0	1/2				1/32				2.560	0.160
7	0	1	1	1				7/16				7/256	2.240	0.140
6	0	1	1	0			3/8				3/128		1.920	0.120
5	0	1	0	1				5/16				2/256	1.600	0.100
4	0	1	0	0		1/4				1/64			1.280	0.080
3	0	0	1	1				163				3/256	0.960	0.060
2	0	0	1	0			1/8				1/128		0.640	0.040
1	0	0	0	1				1/16				1/256	0.320	0.020
0	0	0	0	0									0	0



- (1) *Pin numbers for the DP8228 system controller, others are INS8080A
- (2) Pin 23 of the INS8228 must be tied to +12V through a 1 kΩ resistor to generate the RST 7 instruction when an interrupt is acknowledged as required by the accompanying sample program.

Figure 26. ADC0801_INS8080A CPU Interface

```

0038    C3 00 03    RST 7:          JMP    LD DATA
      .           .           .
      .           .           .
0100    21 00 02    START:          LXI H 0200H      ; HL pair will point to
                                     ; data storage locations
0103    31 00 04    RETURN:        LXI SP 0400H     ; Initialize stack pointer (Note 1)
0106    7D                    MOV A, L        ; Test # of bytes entered
0107    FE 0F                    CPI 0FH        ; If # = 16. JMP to
0109    CA 13 01                    JZ CONT       ; user program
010C    D3 E0                    OUT E0 H      ; Start A/D
010E    FB                    EI             ; Enable interrupt
010F    00                    LOOP:         NOP           ; Loop until end of
0110    C3 0F 01                    JMP LOOP      ; conversion
0113    .           .           .
      .           .           .
      .           .           .
      .           .           .
      .           .           .
      .           .           .
0300    DB E0    LD DATA:    IN E0 H        ; Load data into accumulator
0302    77                    MOV M, A      ; Store data
0303    23                    INX H        ; Increment storage pointer
0304    C3 03 01                    JMP RETURN

```

Note: The stack pointer must be dimensioned because a RST 7 instruction pushes the PC onto the stack.

Note: All address used were arbitrarily chosen.

Figure 27. Sample Program for Figure 26 ADC0801–INS8080A CPU Interface

The standard control bus signals of the 8080 (\overline{CS} , \overline{RD} and \overline{WR}) can be directly wired to the digital control inputs of the ADC and the bus timing requirements are met to allow both starting the converter and outputting the data onto the data bus. A bus driver should be used for larger microprocessor systems where the data bus leaves the PCB and/or must drive capacitive loads larger than 100 pF.

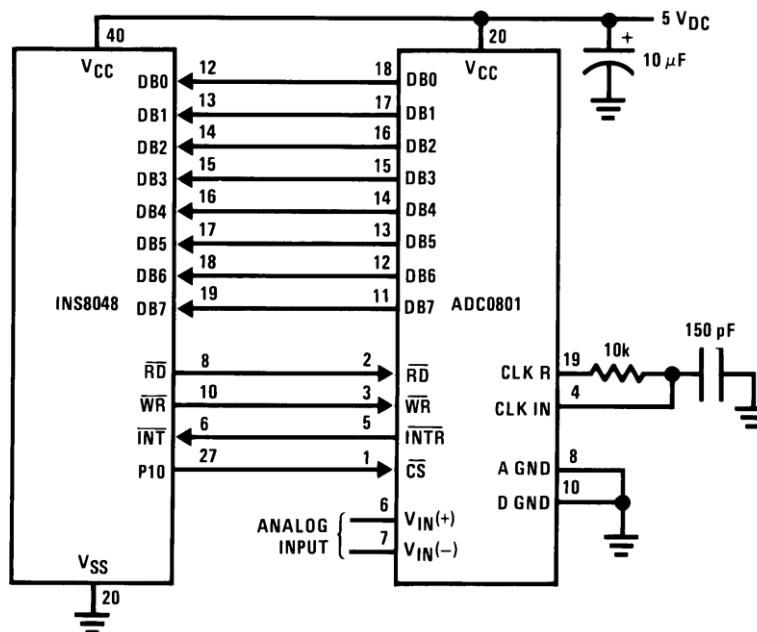
9.1.2.2 Sample 8080A CPU Interfacing Circuitry and Program

The following sample program and associated hardware shown in Figure 26 may be used to input data from the converter to the INS8080A CPU chip set (comprised of the INS8080A microprocessor, the INS8228 system controller and the INS8224 clock generator). For simplicity, the ADC is controlled as an I/O device, specifically an 8-bit bi-directional port located at an arbitrarily chosen port address, E0. The Tri-state output capability of the ADC eliminates the need for a peripheral interface device, however address decoding is still required to generate the appropriate CS for the converter.

It is important to note in systems where the ADC converter is 1-of-8 or less I/O mapped devices, no address decoding circuitry is necessary. Each of the 8 address bits (A0 to A7) can be directly used as CS inputs — one for each I/O device.

9.1.2.3 INS8048 Interface

The INS8048 interface technique with the ADC0801 series (see Figure 28) is simpler than the 8080A CPU interface. There are 24 I/O lines and three test input lines in the 8048. With these extra I/O lines available, one of the I/O lines (bit 0 of port 1) is used as the chip select signal to the ADC, thus eliminating the use of an external address decoder. Bus control signals \overline{RD} , \overline{WR} and \overline{INT} of the 8048 are tied directly to the ADC. The 16 converted data words are stored at on-chip RAM locations from 20 to 2F (Hex). The RD and WR signals are generated by reading from and writing into a dummy address, respectively. A sample interface program is shown below.


Figure 28. INS8048 Interface

```

04 10          JMP      10H          : Program starts at addr 10
          ORG      3H
04 50          JMP      50H          ; Interrupt jump vector
          ORG      10H              ; Main program
99 FE          ANL      P1, #0FEH    ; Chip select
81             MOVX     A, @R1       ; Read in the 1st data
          ; to reset the intr
89 01          START:  ORL      P1, #1 ; Set port pin high
B8 20          MOV      R0, #20H     ; Data address
B9 FF          MOV      R1, #0FFH    ; Dummy address
BA 10          MOV      R2, #10H     ; Counter for 16 bytes
23 FF          AGAIN:  MOV      A, #0FFH ; Set ACC for intr loop
99 FE          ANL      P1, #0FEH    ; Send CS (bit 0 of P1)
91             MOVX     @R1, A       ; Send WR out
05             EN                    ; Enable interrupt
96 21          LOOP:   JNZ      LOOP  ; Wait for interrupt
EA 1B          DJNZ     R2, AGAIN     ; If 16 bytes are read
00             NOP
00             NOP
          ORG      50H
81             INDATA: MOVX     A, @R1 ; Input data, CS still low
A0             MOV      @R0, A       ; Store in memory
18             INC      R0           ; Increment storage counter
89 01          ORL      P1, #1       ; Reset CS signal
27             CLR      A           ; Clear ACC to get out of
93             RETR                    ; the interrupt loop
    
```

Figure 29. Sample Program for Figure 28 INS8048 Interface

9.1.2.4 Interfacing the Z-80

The Z-80 control bus is slightly different from that of the 8080. General \overline{RD} and \overline{WR} strobes are provided and separate memory request, \overline{MREQ} , and I/O request, \overline{IORQ} , signals are used which have to be combined with the generalized strobes to provide the equivalent 8080 signals. An advantage of operating the ADC in I/O space with the Z-80 is that the CPU will automatically insert one wait state (the \overline{RD} and \overline{WR} strobes are extended one clock period) to allow more time for the I/O devices to respond. Logic to map the ADC in I/O space is shown in Figure 30.

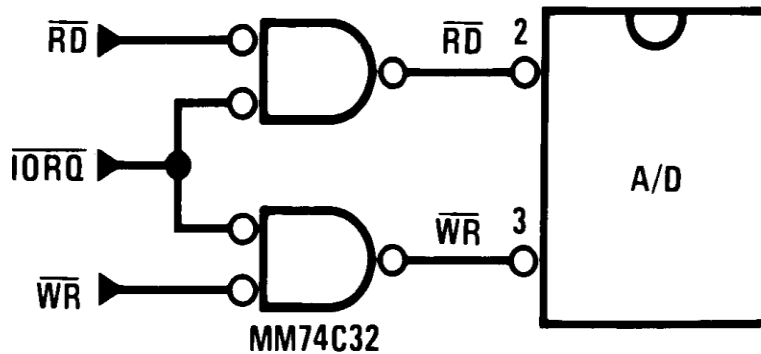


Figure 30. Mapping the ADC as an I/O Device for Use With the Z-80 CPU

Additional I/O advantages exist as software DMA routines are available and use can be made of the output data transfer which exists on the upper 8 address lines (A8 to A15) during I/O input instructions. For example, MUX channel selection for the ADC can be accomplished with this operating mode.

9.1.2.5 Interfacing 6800 Microprocessor Derivatives (6502, etc.)

The control bus for the 6800 microprocessor derivatives does not use the \overline{RD} and \overline{WR} strobe signals. Instead it employs a single R/W line and additional timing, if needed, can be derived from the $\phi 2$ clock. All I/O devices are memory mapped in the 6800 system, and a special signal, VMA, indicates that the current address is valid. Figure 36 shows an interface schematic where the ADC is memory mapped in the 6800 system. For simplicity, the \overline{CS} decoding is shown using 1/2 DM8092. Note in many 6800 systems, an already decoded $\overline{4/5}$ line is brought out to the common bus at pin 21. This can be tied directly to the \overline{CS} pin of the ADC, provided that no other devices are addressed at HX ADDR: 4XXX or 5XXX.

The following subroutine performs essentially the same function as in the case of the 8080A interface and it can be called from anywhere in the user's program.

In Figure 38 the ADC0801 series is interfaced to the M6800 microprocessor through (the arbitrarily chosen) Port B of the MC6820 or MC6821 Peripheral Interface Adapter, (PIA).

Here the \overline{CS} pin of the ADC is grounded because the PIA is already memory mapped in the M6800 system and no \overline{CS} decoding is necessary. Also notice that the ADC output data lines are connected to the microprocessor bus under program control through the PIA and therefore the ADC \overline{RD} pin can be grounded.

A sample interface program equivalent to the previous one is shown below Figure 38. The PIA Data and Control Registers of Port B are located at HEX addresses 8006 and 8007, respectively.

9.2 Typical Applications

9.2.1 8080 Interface

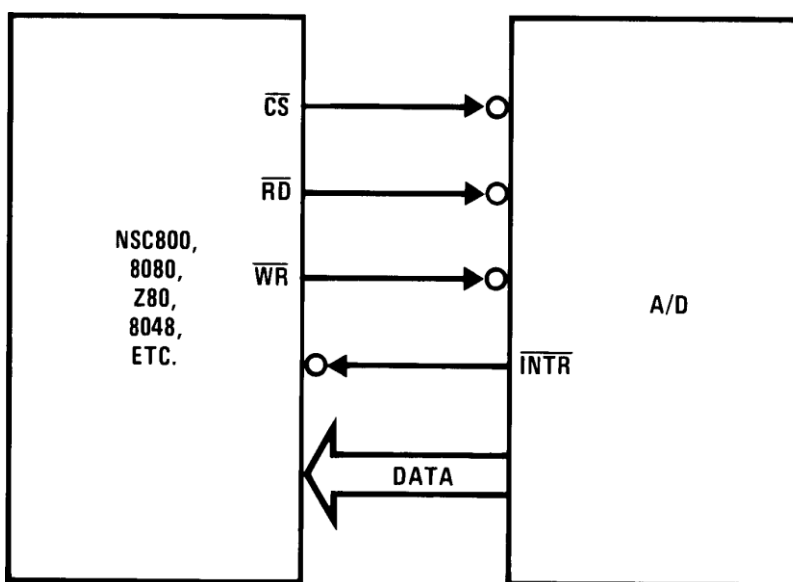
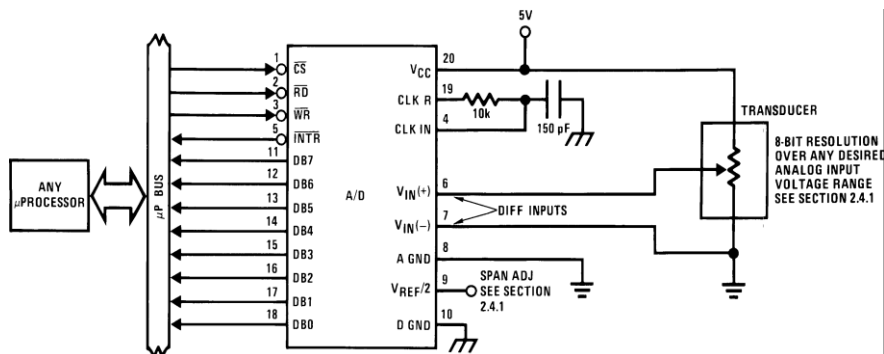


Figure 31. Generic Interface Between ADC and 8-Bit μ Ps

ERROR SPECIFICATION (Includes Full-Scale, Zero Error, and Non-Linearity)			
PART NUMBER	FULL-SCALE ADJUSTED	$V_{REF/2} = 2.500 V_{DC}$ (No Adjustments)	$V_{REF/2} = \text{No Connection}$ (No Adjustments)
ADC0801	$\pm 1/4$ LSB		
ADC0802		$\pm 1/2$ LSB	
ADC0803	$\pm 1/2$ LSB		
ADC0804		± 1 LSB	
ADC0805			± 1 LSB

9.2.1.1 Design Requirements

For these example applications, the input analog signal is differential to illustrate the offset and common mode reduction merits. An example of the use of an adjusted reference voltage is to accommodate a reduced span or dynamic voltage range of the analog input voltage is also depicted.

Table 2. Design Parameters

PARAMETER	EXAMPLE VALUE
ADC clock frequency, F_{CLK}	640 KHz
Input source resistance, R_{IN}	100 Ω

9.2.1.2 Detailed Design Procedure

9.2.1.2.1 Analog Differential Voltage Inputs and Common-Mode Rejection

This ADC has additional applications flexibility due to the analog differential voltage input. The $V_{IN(-)}$ input (pin 7) can be used to automatically subtract a fixed voltage value from the input reading (tare correction). This is also useful in 4 mA–20 mA current loop conversion. In addition, common-mode noise can be reduced by use of the differential input.

The time interval between sampling $V_{IN(+)}$ and $V_{IN(-)}$ is 4-1/2 clock periods. The maximum error voltage due to this slight time difference between the input voltage samples is given by:

$$\Delta V_e (\text{MAX}) = (V_P)(2\pi f_{cm}) \left(\frac{4.5}{f_{CLK}} \right)$$

where

- ΔV_e is the error voltage due to sampling delay
 - V_P is the peak value of the common-mode voltage
 - f_{cm} is the common-mode frequency
- (1)

As an example, to keep this error to 1/4 LSB (~5 mV) when operating with a 60 Hz common-mode frequency, f_{cm} , and using a 640 kHz ADC clock, f_{CLK} , would allow a peak value of the common-mode voltage, V_P , which is given by:

$$V_P = \frac{[\Delta V_e (\text{MAX}) (f_{CLK})]}{(2\pi f_{cm})(4.5)}$$
(2)

or

$$V_P = \frac{(5 \times 10^{-3})(640 \times 10^3)}{(6.28)(60)(4.5)}$$
(3)

which gives V_P –1.9 V.

The allowed range of analog input voltages usually places more severe restrictions on input common-mode noise levels.

An analog input voltage with a reduced span and a relatively large zero offset can be handled easily by making use of the differential input (see [Reference Voltage](#)).

9.2.1.2.2 Analog Inputs — Input Current

9.2.1.2.2.1 Input Bypass Capacitors

Bypass capacitors at the inputs will average these charges and cause a DC current to flow through the output resistances of the analog signal sources. This charge pumping action is worse for continuous conversions with the $V_{IN(+)}$ input voltage at full-scale. For continuous conversions with a 640 kHz clock frequency with the $V_{IN(+)}$ input at 5V, this DC current is at a maximum of approximately 5 μ A. Therefore, *bypass capacitors should not be used at the analog inputs or the $V_{REF}/2$ pin* for high resistance sources (> 1 k Ω). If input bypass capacitors are necessary for noise filtering and high source resistance is desirable to minimize capacitor size, the detrimental effects of the voltage drop across this input resistance, which is due to the average value of the input current, can be eliminated with a full-scale adjustment while the given source resistor and input bypass capacitor are both in place. This is possible because the average value of the input current is a precise linear function of the differential input voltage.

9.2.1.2.2.2 Input Source Resistance

Large values of source resistance where an input bypass capacitor is not used, *will not cause errors* as the input currents settle out prior to the comparison time. If a low pass filter is required in the system, use a low valued series resistor ($\leq 1 \text{ k}\Omega$) for a passive RC section or add an op amp RC active low pass filter. For low source resistance applications, ($\leq 1 \text{ k}\Omega$), a $0.1 \mu\text{F}$ bypass capacitor at the inputs will prevent noise pickup due to series lead inductance of a long wire. A 100Ω series resistor can be used to isolate this capacitor — both the R and C are placed outside the feedback loop — from the output of an op amp, if used.

9.2.1.2.2.3 Noise

The leads to the analog inputs (pins 6 and 7) should be kept as short as possible to minimize input noise coupling. Both noise and undesired digital clock coupling to these inputs can cause system errors. The source resistance for these inputs should, in general, be kept below $5 \text{ k}\Omega$. Larger values of source resistance can cause undesired system noise pickup. Input bypass capacitors, placed from the analog inputs to ground, will eliminate system noise pickup but can create analog scale errors as these capacitors will average the transient input switching currents of the ADC (see [Analog Inputs — Input Current](#)). This scale error depends on both a large source resistance and the use of an input bypass capacitor. This error can be eliminated by doing a full-scale adjustment of the ADC (adjust $V_{\text{REF}}/2$ for a proper full-scale reading — see [Full-Scale](#)) with the source resistance and input bypass capacitor in place.

Noise spikes on the V_{CC} supply line can cause conversion errors as the comparator will respond to this noise. A low inductance tantalum filter capacitor should be used close to the converter V_{CC} pin and values of $1 \mu\text{F}$ or greater are recommended. If an unregulated voltage is available in the system, a separate LM340LAZ-5.0, TO-92, 5-V voltage regulator for the converter (and other analog circuitry) will greatly reduce digital noise on the V_{CC} supply.

9.2.1.2.3 Reference Voltage

9.2.1.2.3.1 Span Adjust

For maximum applications flexibility, these ADCs have been designed to accommodate a $5 V_{\text{DC}}$, $2.5 V_{\text{DC}}$ or an adjusted voltage reference. This has been achieved in the design of the IC as shown in [Figure 32](#).

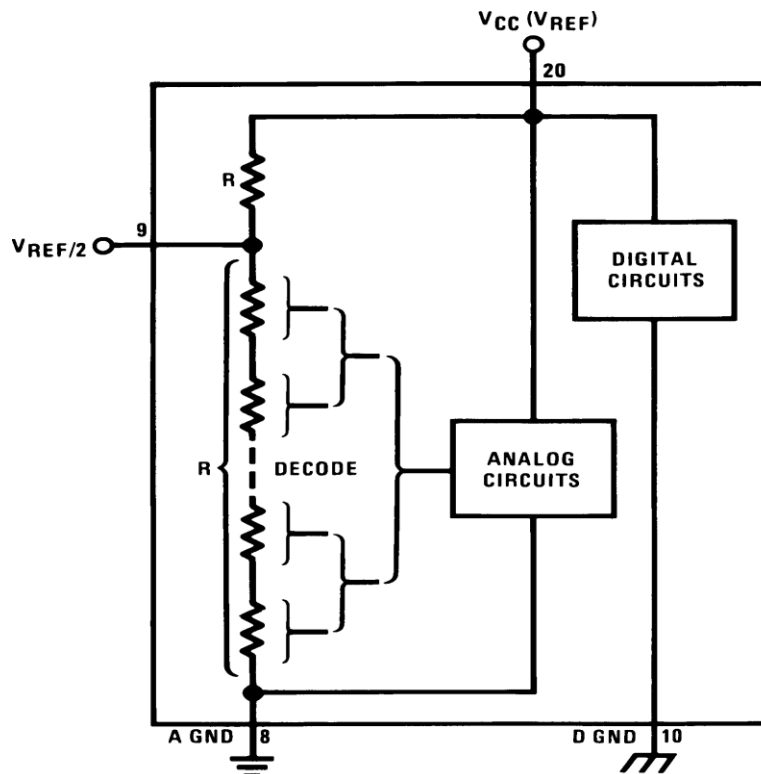


Figure 32. The $V_{\text{REFERENCE}}$ Design on the IC

Notice that the reference voltage for the IC is either 1/2 of the voltage applied to the V_{CC} supply pin, or is equal to the voltage that is externally forced at the $V_{REF}/2$ pin. This allows for a ratiometric voltage reference using the V_{CC} supply, a $5 V_{DC}$ reference voltage can be used for the V_{CC} supply or a voltage less than $2.5 V_{DC}$ can be applied to the $V_{REF}/2$ input for increased application flexibility. The internal gain to the $V_{REF}/2$ input is 2, making the full-scale differential input voltage twice the voltage at pin 9.

An example of the use of an adjusted reference voltage is to accommodate a reduced span — or dynamic voltage range of the analog input voltage. If the analog input voltage were to range from $0.5 V_{DC}$ to $3.5 V_{DC}$, instead of $0V$ to $5 V_{DC}$, the span would be $3 V$ as shown in Figure 33. With $0.5 V_{DC}$ applied to the $V_{IN}(-)$ pin to absorb the offset, the reference voltage can be made equal to 1/2 of the $3V$ span or $1.5 V_{DC}$. The ADC now will encode the $V_{IN}(+)$ signal from $0.5V$ to $3.5 V$ with the $0.5V$ input corresponding to zero and the $3.5 V_{DC}$ input corresponding to full-scale. The full 8 bits of resolution are therefore applied over this reduced analog input voltage range.

9.2.1.2.3.2 Reference Accuracy Requirements

The converter can be operated in a ratiometric mode or an absolute mode. In ratiometric converter applications, the magnitude of the reference voltage is a factor in both the output of the source transducer and the output of the ADC converter and therefore cancels out in the final digital output code. The ADC0805 is specified particularly for use in ratiometric applications with no adjustments required. In absolute conversion applications, both the initial value and the temperature stability of the reference voltage are important factors in the accuracy of the ADC converter. For $V_{REF}/2$ voltages of $2.4 V_{DC}$ nominal value, initial errors of $\pm 10 mV_{DC}$ will cause conversion errors of ± 1 LSB due to the gain of 2 of the $V_{REF}/2$ input. In reduced span applications, the initial value and the stability of the $V_{REF}/2$ input voltage become even more important. For example, if the span is reduced to $2.5 V$, the analog input LSB voltage value is correspondingly reduced from $20 mV$ ($5V$ span) to $10 mV$ and 1 LSB at the $V_{REF}/2$ input becomes $5 mV$. As can be seen, this reduces the allowed initial tolerance of the reference voltage and requires correspondingly less absolute change with temperature variations. Note that spans smaller than $2.5 V$ place even tighter requirements on the initial accuracy and stability of the reference source.

In general, the magnitude of the reference voltage will require an initial adjustment. Errors due to an improper value of reference voltage appear as full-scale errors in the ADC transfer function. IC voltage regulators may be used for references if the ambient temperature changes are not excessive. The LM336B 2.5-V IC reference diode (from National Semiconductor) has a temperature stability of $1.8 mV$ typical ($6 mV$ maximum) over $0^{\circ}C \leq T_A \leq +70^{\circ}C$. Other temperature range parts are also available.

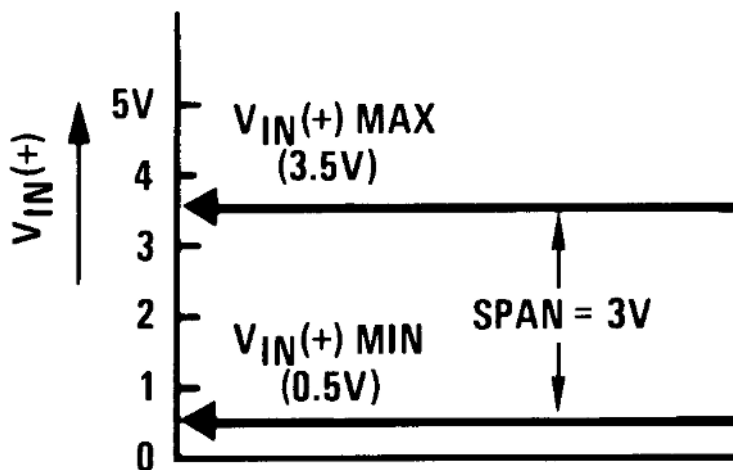
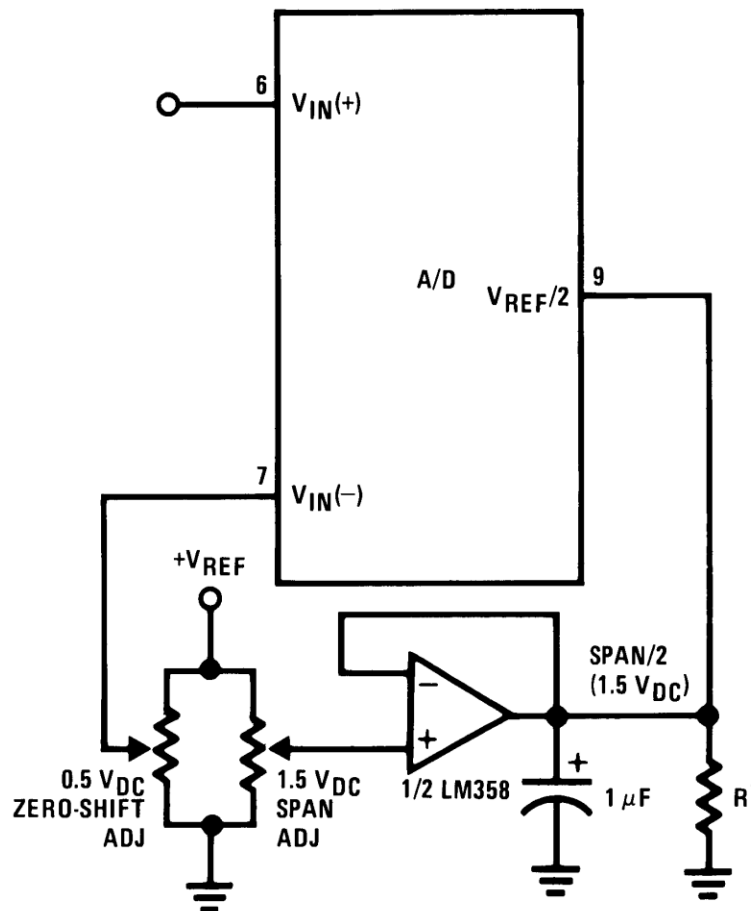


Figure 33. Analog Input Signal Example



*Add if $V_{REF/2} \leq 1$ VDC with LM358 to draw 3 mA to ground.

Figure 34. Accommodating an Analog Input from 0.5V (Digital Out = 00_{HEX}) to 3.5 V (Digital Out=FF_{HEX})

9.2.1.2.4 Errors and Reference Voltage Adjustments

9.2.1.2.4.1 Zero Error

The zero of the ADC does not require adjustment. If the minimum analog input voltage value, $V_{IN(MIN)}$, is not ground, a zero offset can be done. The converter can be made to output 0000 0000 digital code for this minimum input voltage by biasing the ADC $V_{IN(-)}$ input at this $V_{IN(MIN)}$ value (see [Application Information](#)). This uses the differential mode operation of the ADC.

The zero error of the ADC converter relates to the location of the first riser of the transfer function and can be measured by grounding the $V_{IN(-)}$ input and applying a small magnitude positive voltage to the $V_{IN(+)}$ input. Zero error is the difference between the actual DC input voltage that is necessary to just cause an output digital code transition from 0000 0000 to 0000 0001 and the ideal 1/2 LSB value ($1/2$ LSB = 9.8 mV for $V_{REF/2}=2.500$ V_{DC}).

9.2.1.2.4.2 Full-Scale

The full-scale adjustment can be made by applying a differential input voltage that is 11/2 LSB less than the desired analog full-scale voltage range and then adjusting the magnitude of the $V_{REF/2}$ input (pin 9 or the V_{CC} supply if pin 9 is not used) for a digital output code that is just changing from 1111 1110 to 1111 1111.

9.2.1.2.4.3 Adjusting for an Arbitrary Analog Input Voltage Range

If the analog zero voltage of the ADC is shifted away from ground (for example, to accommodate an analog input signal that does not go to ground) this new zero reference should be properly adjusted first. A $V_{IN(+)}$ voltage that equals this desired zero reference plus 1/2 LSB (where the LSB is calculated for the desired analog span, 1 LSB=analog span/256) is applied to pin 6 and the zero reference voltage at pin 7 should then be adjusted to just obtain the 00_{HEX} to 01_{HEX} code transition.

The full-scale adjustment should then be made (with the proper $V_{IN(-)}$ voltage applied) by forcing a voltage to the $V_{IN(+)}$ input which is given by:

$$V_{IN(+)} \text{ fs adj} = V_{MAX} - 1.5 \left[\frac{(V_{MAX} - V_{MIN})}{256} \right]$$

where

- V_{MAX} = The high end of the analog input range
- V_{MIN} = the low end (the offset zero) of the analog range. (Both are ground referenced.)

The $V_{REF}/2$ (or V_{CC}) voltage is then adjusted to provide a code change from FE_{HEX} to FF_{HEX}. This completes the adjustment procedure

9.2.1.2.5 Clocking Option

The clock for the ADC can be derived from the CPU clock or an external RC can be added to provide self-clocking. The CLK IN (pin 4) makes use of a Schmitt trigger as shown in Figure 35.

$$f_{CLK} = \frac{1}{RC \ln \left[\left(\frac{V_{CC} - V_{T-}}{V_{CC} - V_{T+}} \right) \left(\frac{V_{T+}}{V_{T-}} \right) \right]}$$

$$R \cong 10 \text{ k}\Omega$$

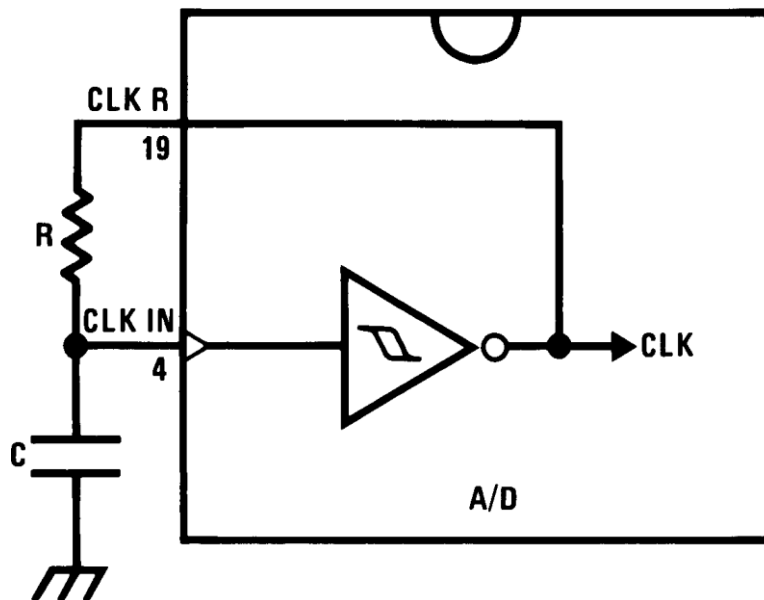


Figure 35. Self-Clocking the ADC

Heavy capacitive or DC loading of the clock R pin should be avoided as this will disturb normal converter operation. Loads less than 50 pF, such as driving up to 7 ADC converter clock inputs from a single clock R pin of 1 converter, are allowed. For larger clock line loading, a CMOS or low power TTL buffer or PNP input logic should be used to minimize the loading on the clock R pin (do not use a standard TTL buffer).

9.2.1.2.6 Restart During a Conversion

If the ADC is restarted ($\overline{\text{CS}}$ and $\overline{\text{WR}}$ go low and return high) during a conversion, the converter is reset and a new conversion is started. The output data latch is not updated if the conversion in process is not allowed to be completed, therefore the data of the previous conversion remains in this latch. The INTR output simply remains at the “1” level.

9.2.1.2.7 Continuous Conversions

For operation in the free-running mode an initializing pulse should be used, following power up, to ensure circuit operation. In this application, the $\overline{\text{CS}}$ input is grounded and the $\overline{\text{WR}}$ input is tied to the INTR output. This $\overline{\text{WR}}$ and INTR node should be momentarily forced to logic low following a power-up cycle to ensure operation.

9.2.1.2.8 Driving the Data Bus

This MOS ADC, like MOS microprocessors and memories, will require a bus driver when the total capacitance of the data bus gets large. Other circuitry, which is tied to the data bus, will add to the total capacitive loading, even in Tri-state (high impedance mode). Backplane bussing also greatly adds to the stray capacitance of the data bus.

There are some alternatives available to the designer to handle this problem. Basically, the capacitive loading of the data bus slows down the response time, even though DC specifications are still met. For systems operating with a relatively slow CPU clock frequency, more time is available in which to establish proper logic levels on the bus and therefore higher capacitive loads can be driven (see typical characteristics curves).

At higher CPU clock frequencies time can be extended for I/O reads (and/or writes) by inserting wait states (8080) or using clock extending circuits (6800).

Finally, if time is short and capacitive loading is high, external bus drivers must be used. These can be Tri-state buffers (low power Schottky such as the DM74LS240 series is recommended) or special higher drive current products which are designed as bus drivers. High current bipolar bus drivers with PNP inputs are recommended.

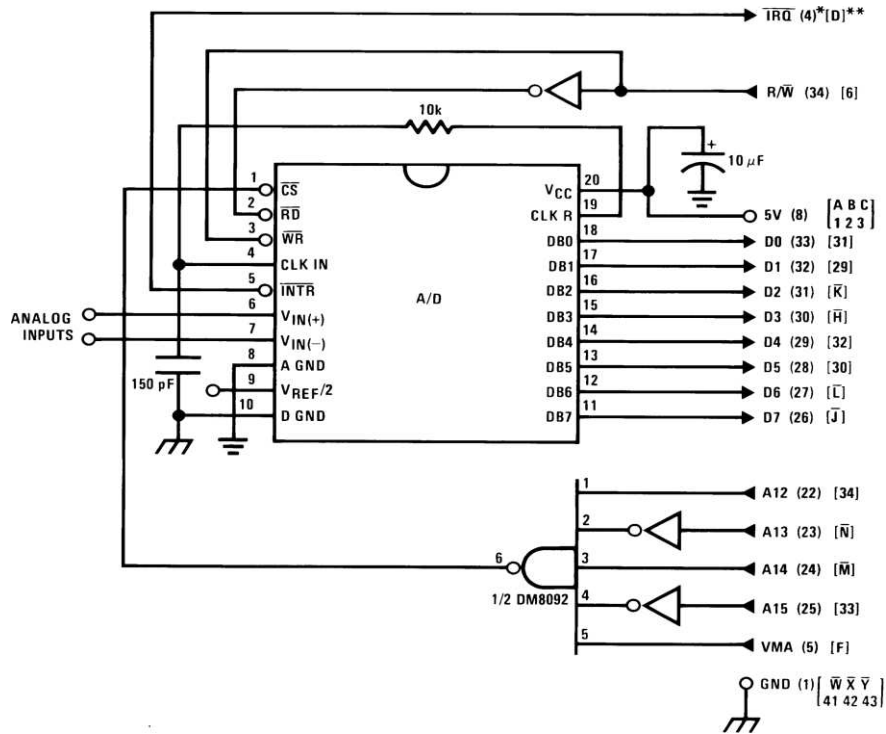
9.2.1.2.9 Wiring and Hook-Up Precautions

Standard digital wire wrap sockets are not satisfactory for breadboarding this ADC converter. Sockets on PCBs can be used and all logic signal wires and leads should be grouped and kept as far away as possible from the analog signal leads. Exposed leads to the analog inputs can cause undesired digital noise and hum pickup, therefore shielded leads may be necessary in many applications.

A single point analog ground that is separate from the logic ground points should be used. The power supply bypass capacitor and the self-clocking capacitor (if used) should both be returned to digital ground. Any $V_{\text{REF}}/2$ bypass capacitors, analog input filter capacitors, or input signal shielding should be returned to the analog ground point. A test for proper grounding is to measure the zero error of the ADC converter. Zero errors in excess of 1/4 LSB can usually be traced to improper board layout and wiring (see [Zero Error](#) for measuring the zero error).

9.2.2 Multiple ADC0801 Series to MC6800 CPU Interface

To transfer analog data from several channels to a single microprocessor system, a multiple converter scheme presents several advantages over the conventional multiplexer single-converter approach. With the ADC0801 series, the differential inputs allow individual span adjustment for each channel. Furthermore, all analog input channels are sensed simultaneously, which essentially divides the total system servicing time of the microprocessor by the number of channels, because all conversions occur simultaneously. This scheme is shown in [Figure 40](#).



*Numbers in parentheses refer to MC6800 CPU pin out.

**Number or letters in brackets refer to standard M6800 system common bus code.

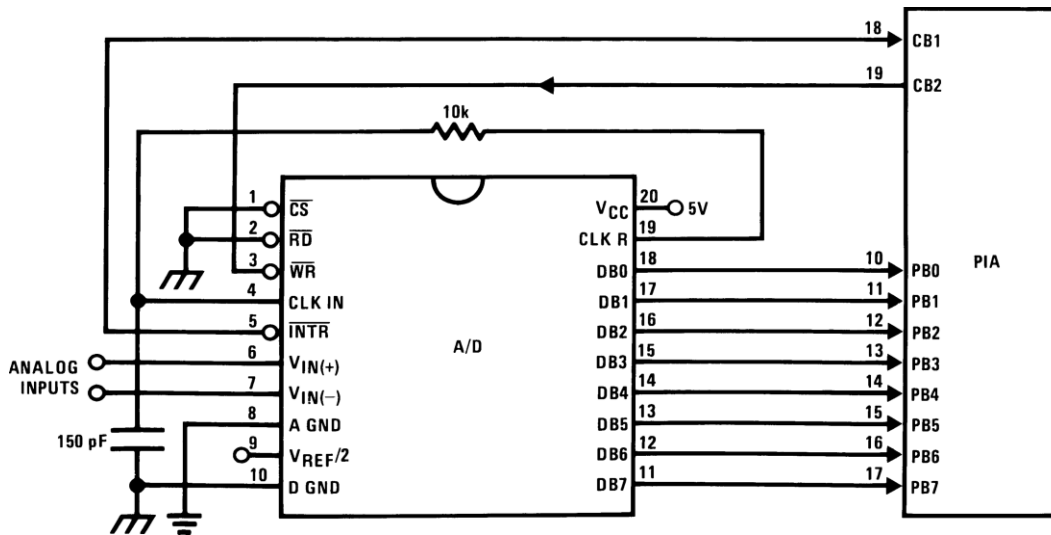
Figure 36. ADC0801-MC6800 CPU Interface

```

0010    DF 36          DATAIN    STX      TEMP2          ; Save contents of X
0012    CE 00 2C          LDX      #$002C          ; Upon IRQ low CPU
0015    FF FF F8          STX      $FFF8          ; jumps to 002C
0018    B7 50 00          STAA     $5000          ; Start ADC0801
001B    0E              CLI              ;
001C    3E              CONVRT    WAI              ; Wait for interrupt
001D    DE 34          LDX      TEMP1          ;
001F    8C 02 0F          CFX      #$020F          ; Is final data stored?
0022    27 14          BEQ      ENDP          ;
0024    B7 50 00          STAA     $5000          ; Restarts ADC0801
0027    08              INX              ;
0028    DF 34          STX      TEMP1          ;
002A    20 F0          BRA      CONVRT          ;
002C    DE 34          INTRPT    LDX      TEMP1          ;
002E    B6 50 00          LDAA     $5000          ; Read data
0031    A7 00          STAA     X              ; Store it at X
0033    3B              RTI              ;
0034    02 00          TEMP1    FDB      $0200          ; Starting address for
                                ; data storage
0036    00 00          TEMP2    FDB      $0000          ;
0038    CE 02 00          ENDP     LDX      #$0200          ; Reinitialize TEMP1
003B    DF 34          STX      TEMP1          ;
003D    DE 36          LDX      TEMP2          ;
003F    39              RTS              ; Return from subroutine
                                ; To user's program
    
```

In order for the microprocessor to service subroutines and inter-rupts, the stack pointer must be dimensioned in the user's program.

Figure 37. Sample Program for Figure 36 ADC0801-MC6800 CPU Interface


Figure 38. ADC0801–MC6820 PIA Interface

```

0010    CE 00 38    DATAIN    LDX    #$0038    ; Upon  $\overline{\text{IRQ}}$  low CPU
0013    FF FF F8    STX    $FFF8    ; jumps to 0038
0016    B6 80 06    LDAA    PIAORB    ; Clear possible  $\overline{\text{IRQ}}$  flags
0019    4F    CLRA
001A    B7 80 07    STAA    PIACRB
001D    B7 80 06    STAA    PIAORB    ; Set Port B as input
0020    0E    CLI
0021    C6 34    LDAB    #$34
0023    86 3D    LDAA    #$3D
0025    F7 80 07    CONVRT    STAB    PIACRB    ; Starts ADC0801
0028    B7 80 07    STAA    PIACRB
002B    3E    WAI    ; Wait for interrupt
002C    DE 40    LDX    TEMP1
002E    8C 02 0F    CFX    #$020F    ; Is final data stored?
0031    27 0F    BEQ    ENDP
0033    08    INX
0034    DF 40    STX    TEMP1
0036    20 ED    BRA    CONVRT
0038    DE 40    INTRPT    LDX    TEMP1
003A    B6 80 06    LDAA    PIAORB    ; Read data in
003D    A7 00    STAA    X    ; Store it at X
003F    3B    RTI
0040    02 00    TEMP1    FDB    $0200    ; Starting address for
    ; data storage
0042    CE 02 00    ENDP    LDX    #$0200    ; Reinitialize TEMP1
0045    DF 40    STX    TEMP1
0047    39    RTS    ; Return from subroutine
    PIAORB    EQU    $8006    ; To user's program
    PIACRB    EQU    $8007
    
```

Figure 39. Sample Program for Figure 38 ADC0801–MC6820 PIA Interface

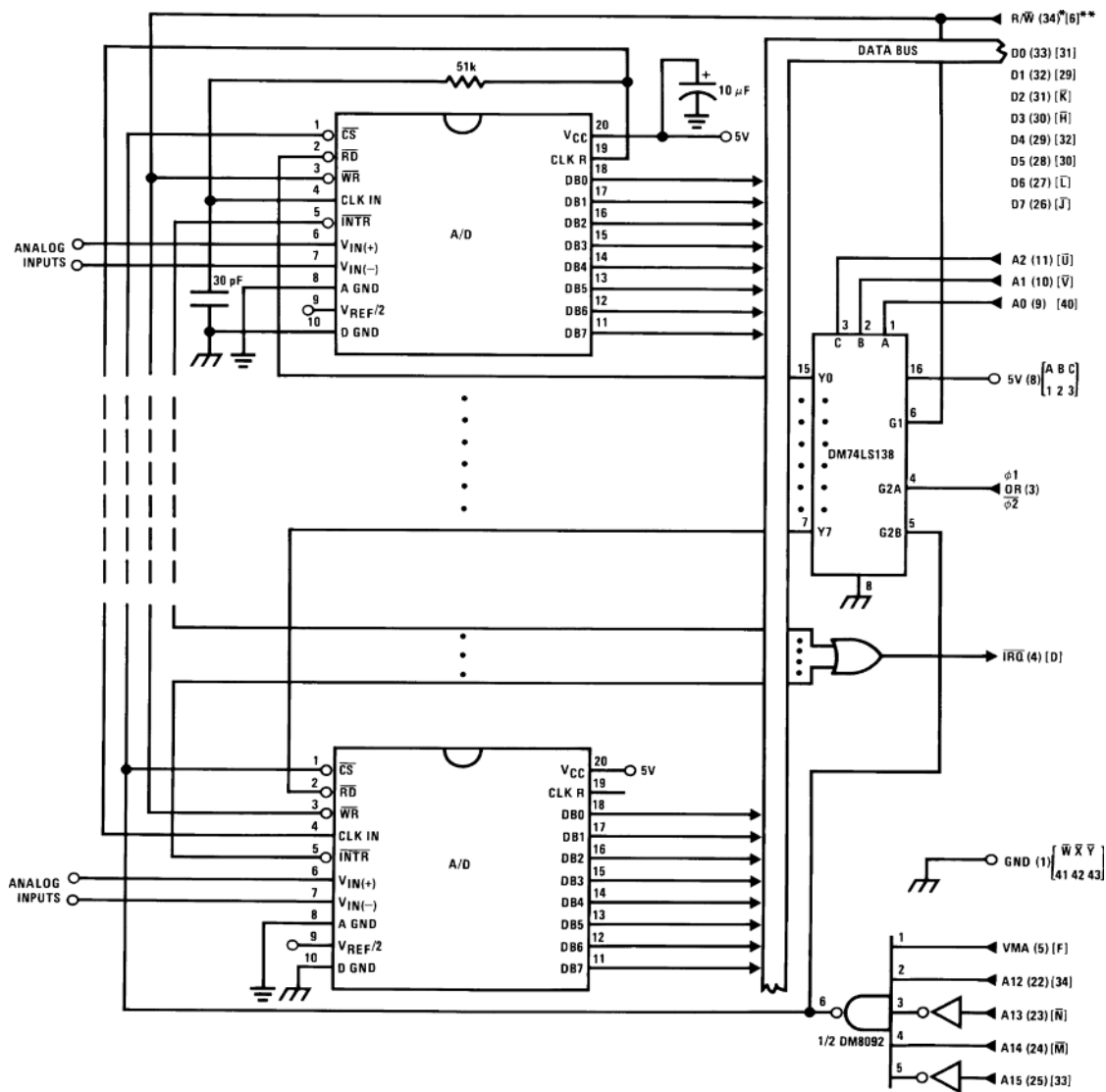
The following schematic and sample subroutine (DATA IN) in [Auto-Zeroed Differential Transducer Amplifier and ADC Converter](#) section may be used to interface (up to) 8 ADC0801's directly to the MC6800 CPU. This scheme can easily be extended to allow the interface of more converters. In this configuration the converters are (arbitrarily) located at HEX address 5000 in the MC6800 memory space. To save components, the clock signal is derived from just one RC pair on the first converter. This output drives the other ADCs.

All the converters are started simultaneously with a STORE instruction at HEX address 5000. Note any other HEX address of the form 5XXX will be decoded by the circuit, pulling all the \overline{CS} inputs low. This can easily be avoided by using a more definitive address decoding scheme. All the interrupts are ORed together to insure that all ADCs have completed their conversion before the microprocessor is interrupted.

The subroutine, DATA IN, may be called from anywhere in the user's program. Once called, this routine initializes the CPU, starts all the converters simultaneously and waits for the interrupt signal. Upon receiving the interrupt, it reads the converters (from HEX addresses 5000 through 5007) and stores the data successively at (arbitrarily chosen) HEX addresses 0200 to 0207, before returning to the user's program. All CPU registers then recover the original data they had before servicing DATA IN.

9.2.3 Auto-Zeroed Differential Transducer Amplifier and ADC Converter

The differential inputs of the ADC0801 series eliminate the need to perform a differential to single ended conversion for a differential transducer. Thus, one op amp can be eliminated because the differential to single ended conversion is provided by the differential input of the ADC0801 series. In general, a transducer preamp is required to take advantage of the full ADC converter input dynamic range.



*Numbers in parentheses refer to MC6800 CPU pin out.

**Numbers of letters in brackets refer to standard M6800 system common bus code.

Figure 40. Interfacing Multiple ADCs in an MC6800 System

ADDRESS	HEX CODE		MNEMONICS		COMMENTS
0010	DF 44	DATAIN	STX	TEMP	; Save Contents of X
0012	CE 00 2A		LDX	#\$002A	; Upon IRQ LOW CPU
0015	FF FF F8		STX	\$FFF8	; Jumps to 002A
0018	B7 50 00		STAA	\$5000	; Starts all A/D's
001B	0E		CLI		
001C	3E		WAI		; Wait for interrupt
001D	CE 50 00		LDX	#\$5000	
0020	DF 40		STX	INDEX1	; Reset both INDEX
0022	CE 02 00		LDX	#\$0200	; 1 and 2 to starting
0025	DF 42		STX	INDEX2	; addresses
0027	DE 44		LDX	TEMP	
0029	39		RTS		; Return from subroutine
002A	DE 40	INTRPT	LDX	INDEX1	; INDEX1 → X
002C	A6 00		LDAA	X	; Read data in from A/D at X
002E	08		INX		; Increment X by one
002F	DF 40		STX	INDEX1	; X → INDEX1
0031	DE 42		LDX	INDEX2	; INDEX2 → X

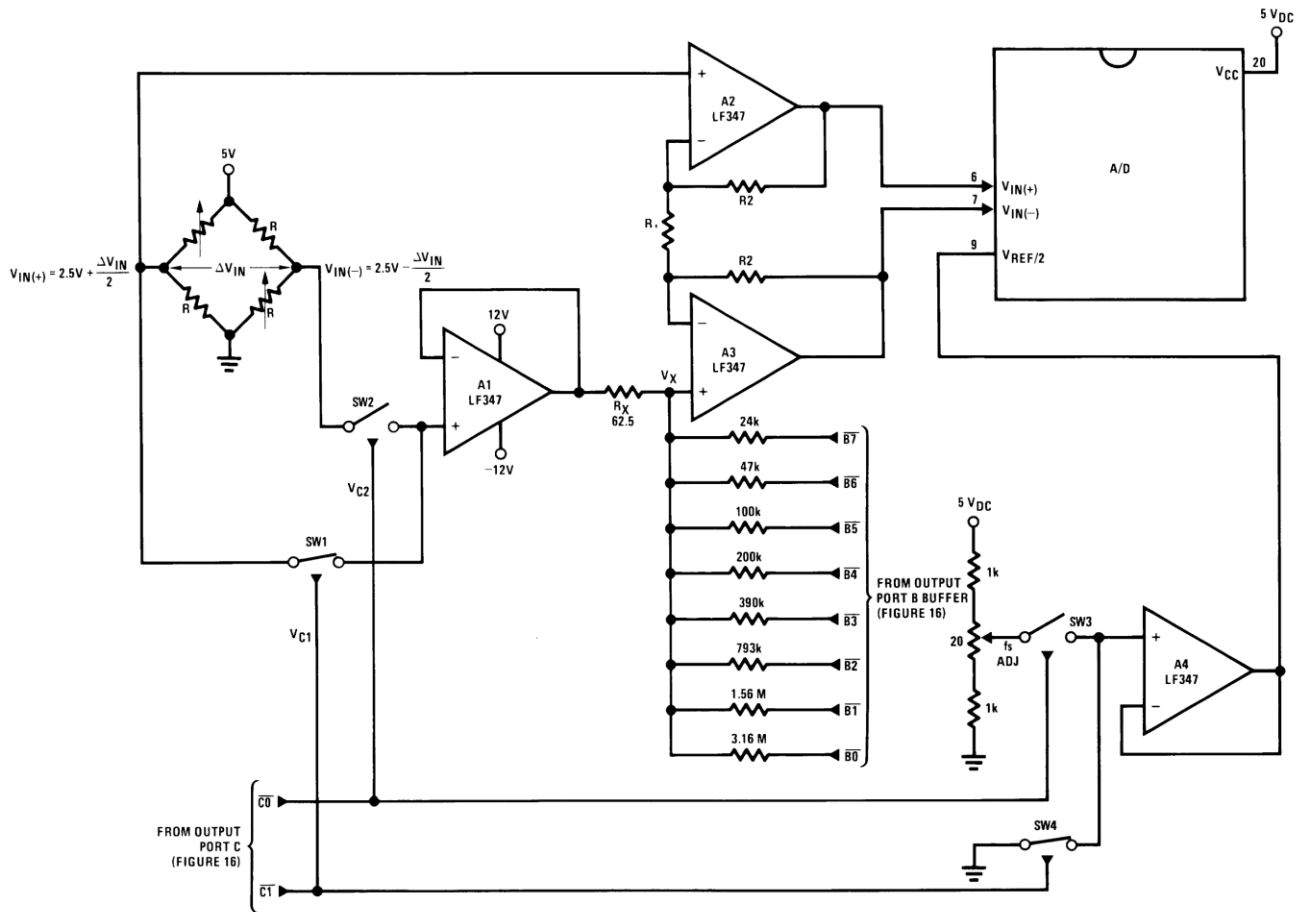
Figure 41. Sample Program for Figure 40 Interfacing Multiple ADC's in an MC6800 System

ADDRESS	HEX CODE		MNEMONICS		COMMENTS
0033	A7 00		STAA	X	; Store data at X
0035	8C 02 07		CPX	#\$0207	; Have all A/D's been read?
0038	27 05		BEQ	RETURN	; Yes: branch to RETURN
003A	08		INX		; No: increment X by one
003B	DF 42		STX	INDEX2	; X → INDEX2
003D	20 EB		BRA	INTRPT	; Branch to 002A
003F	3B	RETURN	RTI		
0040	50 00	INDEX1	FDB	\$5000	; Starting address for A/D
0042	02 00	INDEX2	FDB	\$0200	; Starting address for data storage
0044	00 00	TEMP	FDB	\$0000	

Figure 42. Sample Program for Figure 40 Interfacing Multiple ADC's in an MC6800 System

Note: In order for the microprocessor to service subroutines and interrupts, the stack pointer must be dimensioned in the user's program.

For amplification of DC input signals, a major system error is the input offset voltage of the amplifiers used for the preamp. Figure 43 is a gain of 100 differential preamp whose offset voltage errors will be cancelled by a zeroing subroutine which is performed by the INS8080A microprocessor system. The total allowable input offset voltage error for this preamp is only 50 μ V for $1/4$ LSB error. This would obviously require very precise amplifiers. The expression for the differential output voltage of the preamp is:



$$R2 = 49.5 R1$$

Switches are LMC13334 CMOS analog switches.

The 9 resistors used in the auto-zero section can be $\pm 5\%$ tolerance.

Figure 43. Gain of 100 Differential Transducer Preamp

$$V_O = \underbrace{[V_{IN(+)} - V_{IN(-)}]}_{\text{SIGNAL}} \underbrace{\left[1 + \frac{2R2}{R1}\right]}_{\text{GAIN}} + \underbrace{(V_{OS2} - V_{OS1} - V_{OS3} \pm I_X R_X)}_{\text{DC ERROR TERM}} \underbrace{\left(1 + \frac{2R2}{R1}\right)}_{\text{GAIN}}$$

where

- I_X is the current through resistor R_X (5)

All of the offset error terms can be cancelled by making $\pm I_X R_X = V_{OS1} + V_{OS3} - V_{OS2}$. This is the principle of this auto-zeroing scheme.

The INS8080A uses the 3 I/O ports of an INS8255 Programmable Peripheral Interface (PPI) to control the auto zeroing and input data from the ADC0801 as shown in Figure 44. The PPI is programmed for basic I/O operation (mode 0) with Port A being an input port and Ports B and C being output ports. Two bits of Port C are used to alternately open or close the 2 switches at the input of the preamp. Switch SW1 is closed to force the preamp's differential input to be zero during the zeroing subroutine and then opened and SW2 is then closed for conversion of the actual differential input signal. Using 2 switches in this manner eliminates concern for the ON resistance of the switches as they must conduct only the input bias current of the input amplifiers.

Output Port B is used as a successive approximation register by the 8080 and the binary scaled resistors in series with each output bit create a D/A converter. During the zeroing subroutine, the voltage at V_x increases or decreases as required to make the differential output voltage equal to zero. This is accomplished by ensuring that the voltage at the output of A1 is approximately 2.5V so that a logic "1" (5V) on any output of Port B will source current into node V_x thus raising the voltage at V_x and making the output differential more negative. Conversely, a logic "0" (0V) will pull current out of node V_x and decrease the voltage, causing the differential output to become more positive. For the resistor values shown, V_x can move ± 12 mV with a resolution of $50 \mu\text{V}$, which will null the offset error term to $1/4$ LSB of full-scale for the ADC0801. It is important that the voltage levels that drive the auto-zero resistors be constant. Also, for symmetry, a logic swing of 0V to 5V is convenient. To achieve this, a CMOS buffer is used for the logic output signals of Port B and this CMOS package is powered with a stable 5V source. Buffer amplifier A1 is necessary so that it can source or sink the D/A output current.

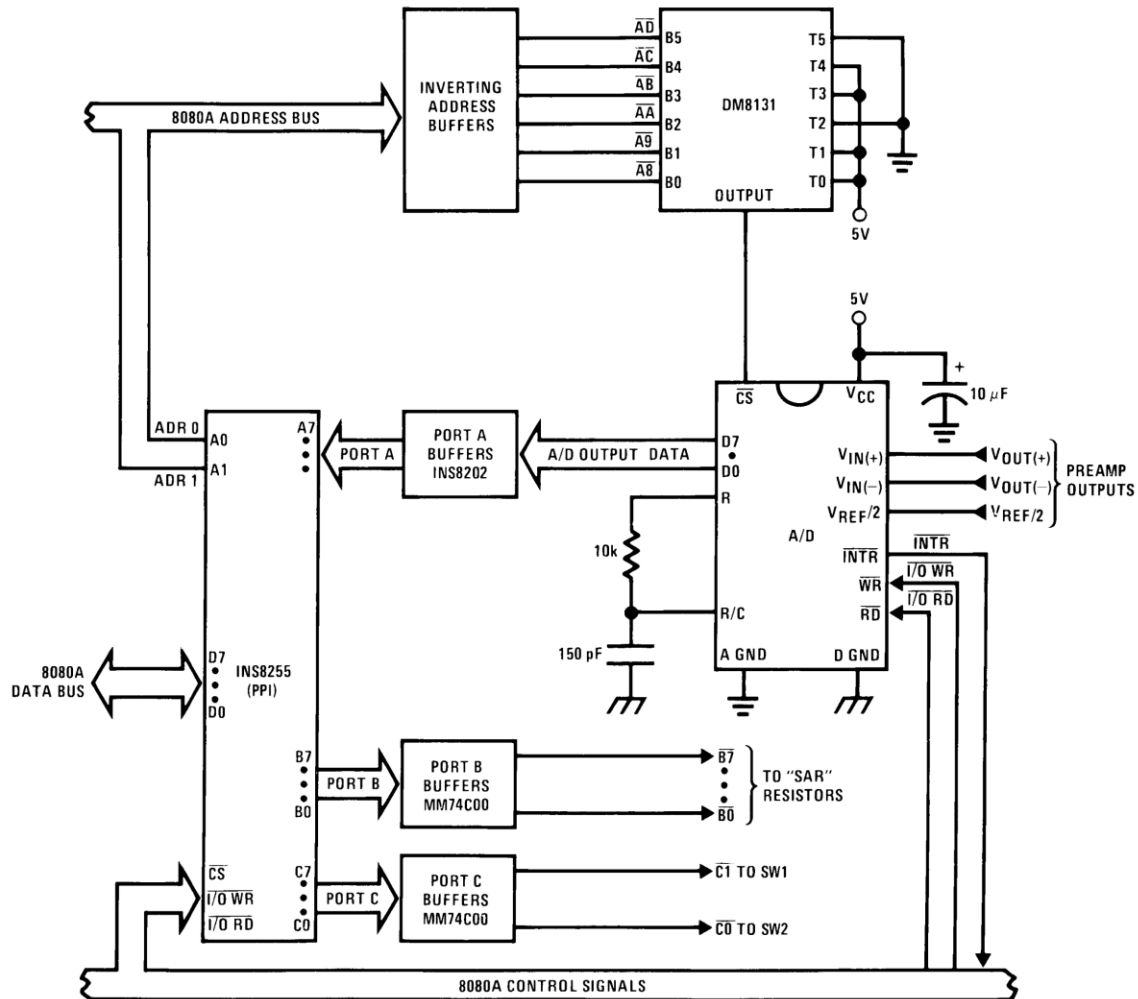


Figure 44. Microprocessor Interface Circuitry for Differential Preamp

A flow chart for the zeroing subroutine is shown in [Figure 45](#). It must be noted that the ADC0801 series will output an all zero code when it converts a negative input [$V_{IN(-)} \geq V_{IN(+)}$]. Also, a logic inversion exists as all of the I/O ports are buffered with inverting gates.

Basically, if the data read is zero, the differential output voltage is negative, so a bit in Port B is cleared to pull V_x more negative which will make the output more positive for the next conversion. If the data read is not zero, the output voltage is positive so a bit in Port B is set to make V_x more positive and the output more negative. This continues for 8 approximations and the differential output eventually converges to within 5 mV of zero.

The actual program is given in [Figure 46](#). All addresses used are compatible with the BLC 80/10 microcomputer system. In particular:

- Port A and the ADC0801 are at port address E4
- Port B is at port address E5
- Port C is at port address E6
- PPI control word port is at port address E7
- Program Counter automatically goes to ADDR:3C3D upon acknowledgment of an interrupt from the ADC0801

9.2.4 Multiple ADC Converters in a Z-80 Interrupt Driven Mode

In data acquisition systems where more than one ADC converter (or other peripheral device) will be interrupting program execution of a microprocessor, there is obviously a need for the CPU to determine which device requires servicing. Figure 47 and the accompanying software is a method of determining which of 7 ADC0801 converters has completed a conversion ($\overline{\text{INTR}}$ asserted) and is requesting an interrupt. This circuit allows starting the ADC converters in any sequence, but will input and store valid data from the converters with a priority sequence of ADC 1 being read first, ADC 2 second, etc., through ADC 7 which would have the lowest priority for data being read. Only the converters whose INT is asserted will be read.

The key to decoding circuitry is the DM74LS373, 8-bit D type flip-flop. When the Z-80 acknowledges the interrupt, the program is vectored to a data input Z-80 subroutine. This subroutine will read a peripheral status word from the DM74LS373 which contains the logic state of the $\overline{\text{INTR}}$ outputs of all the converters. Each converter which initiates an interrupt will place a logic "0" in a unique bit position in the status word and the subroutine will determine the identity of the converter and execute a data read. An identifier word (which indicates which ADC the data came from) is stored in the next sequential memory location above the location of the data so the program can keep track of the identity of the data entered.

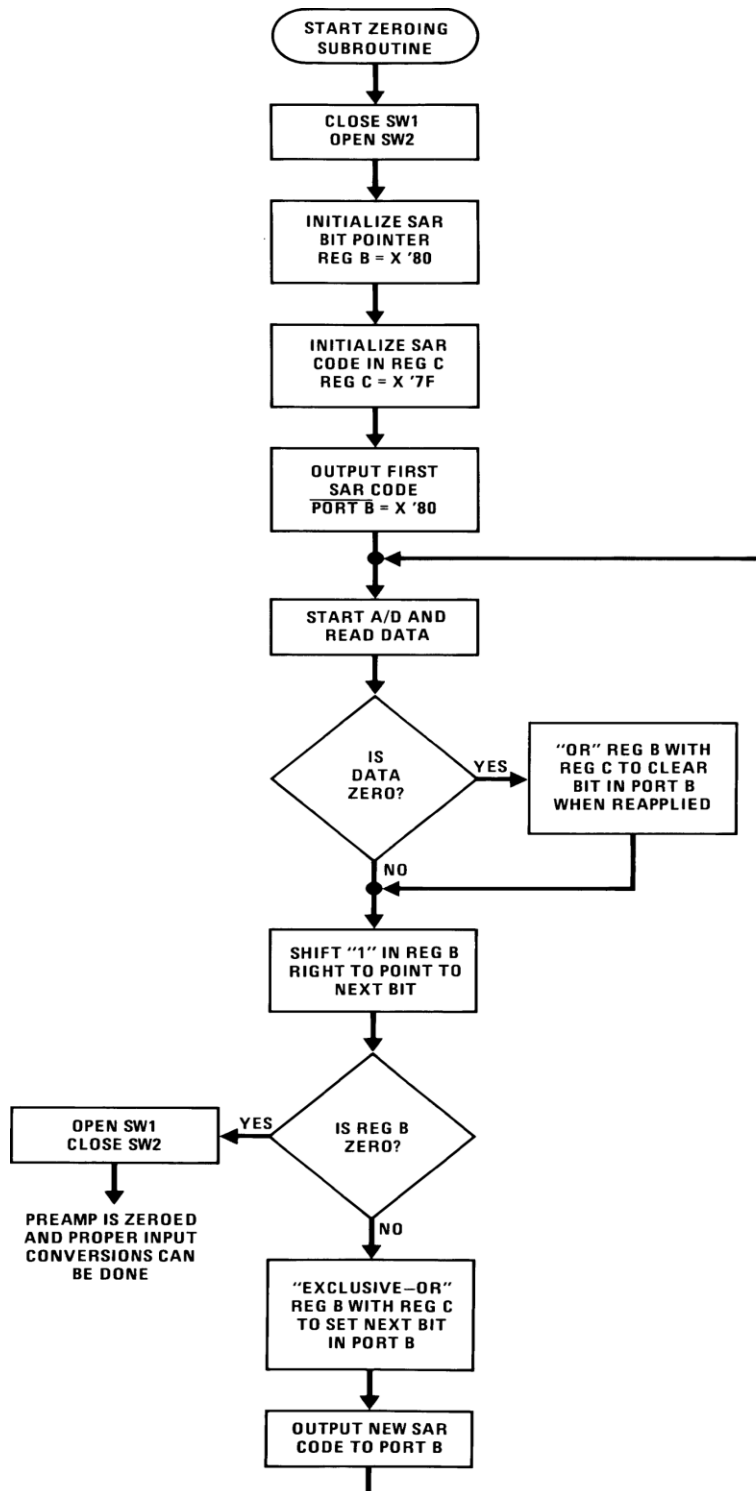


Figure 45. Flow Chart for Auto-Zero Routine

```

3D00 3E90 MVI 90
3D02 D3E7 Out Control Port ; Program PPI
3D04 2601 MVI H 01 Auto-Zero Subroutine
3D06 7C MOV A,H
3D07 D3E6 OUT C ; Close SW1 open SW2
3D09 0680 MVI B 80 ; Initialize SAR bit pointer
3D0B 3E7F MVI A 7F ; Initialize SAR code
3D0D 4F MOV C,A Return
3D0E D3E5 OUT B ; Port B = SAR code
3D10 31AA3D LXI SP 3DAA Start ; Dimension stack pointer
3D13 D3E4 OUT A ; Start A/D
3D15 FB IE
3D16 00 NOP Loop ; Loop until INT asserted
3D17 C3163D JMP Loop
3D1A 7A MOV A,D Auto-Zero
3D1B C600 ADI 00
3D1D CA2D3D JZ Set C ; Test A/D output data for zero
3D20 78 MOV A,B Shift B
3D21 F600 ORI 00 ; Clear carry
3D23 1F RAR ; Shift "1" in B right one place
3D24 FE00 CPI 00 ; Is B zero? If yes last
3D26 CA373D JZ Done ; approximation has been made
3D29 47 MOV B,A
3D2A C3333D JMP New C
3D2D 79 MOV A,C Set C
3D2E B0 ORA B ; Set bit in C that is in same
3D2F 4F MOV C,A ; position as "1" in B
3D30 C3203D JMP Shift B
3D33 A9 XRA C New C ; Clear bit in C that is in
3D34 C30D3D JMP Return ; same position as "1" in B
3D37 47 MOV B,A Done ; then output new SAR code.
3D38 7C MOV A,H ; Open SW1, close SW2 then
3D39 EE03 XRI 03 ; proceed with program. Preamp
3D3B D3E6 OUT C ; is now zeroed.
3D3D . Normal
.
.
.
Program for processing
proper data values
3C3D DBE4 INA Read A/D Subroutine ; Read A/D data
3C3F EEFF XRI FF ; Invert data
3C41 57 MOV D,A
3C42 78 MOV A,B ; Is B Reg = 0? If not stay
3C43 E6FF ANI FF ; in auto zero subroutine
3C45 C21A3D JNZ Auto-Zero
3C48 C33D3D JMP Normal

```

NOTE: All numerical values are hexadecimal representations.

Figure 46. Software for Auto-Zeroed Differential ADC

The following notes apply:

- It is assumed that the CPU automatically performs a RST 7 instruction when a valid interrupt is acknowledged (CPU is in interrupt mode 1). Hence, the subroutine starting address of X0038.
- The address bus from the Z-80 and the data bus to the Z-80 are assumed to be inverted by bus drivers.
- ADC data and identifying words will be stored in sequential memory locations starting at the arbitrarily chosen address X 3E00.
- The stack pointer must be dimensioned in the main program as the RST 7 instruction automatically pushes the PC onto the stack and the subroutine uses an additional 6 stack addresses.
- The peripherals of concern are mapped into I/O space with the following port assignments:

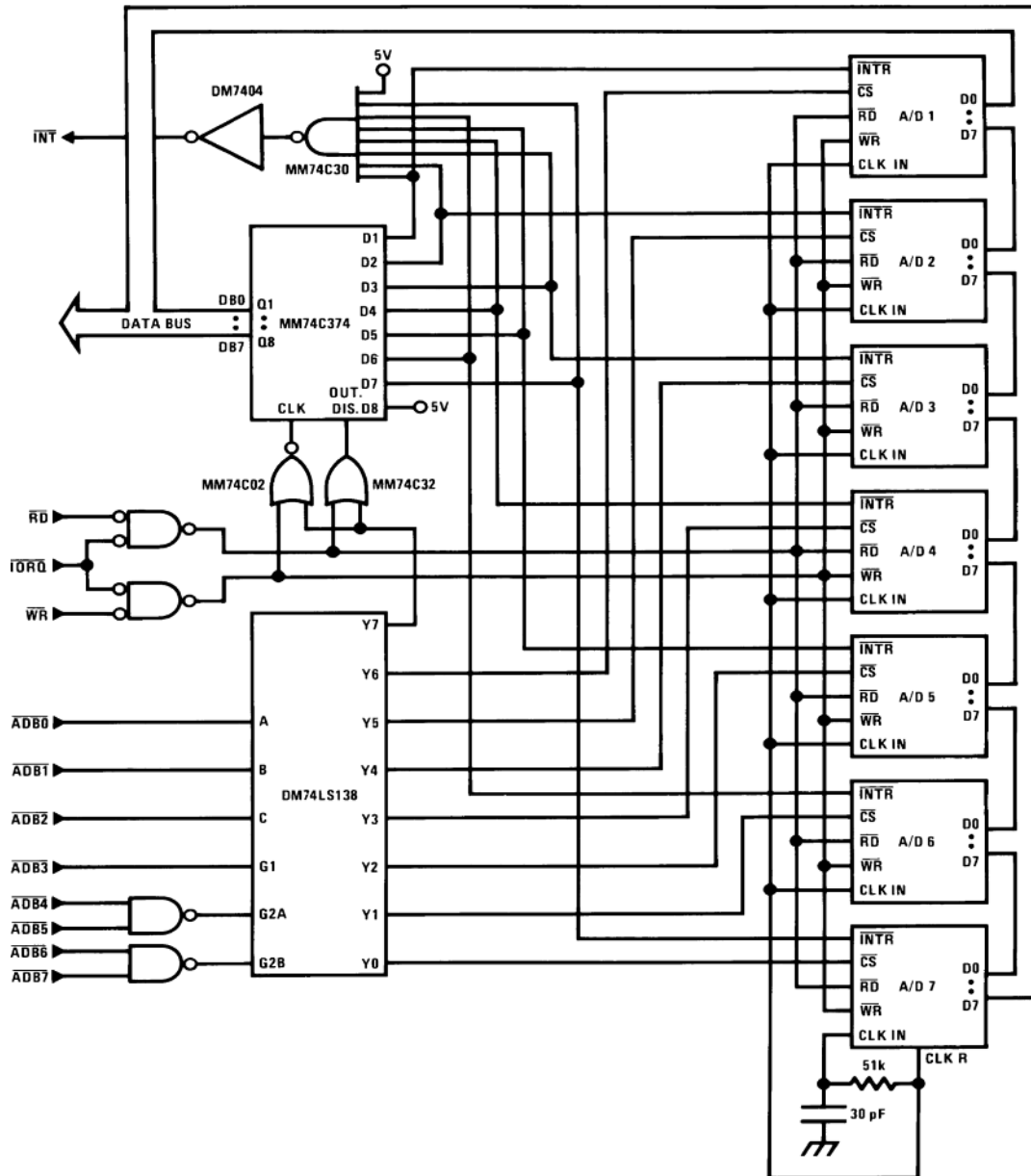
Table 3. Port Assignment Where Peripherals are Mapped into I/O Space

HEX PORT ADDRESS	PERIPHERAL	HEX PORT ADDRESS	PERIPHERAL
00	MM74C374 8-bit flip-flop	04	ADC 4
01	ADC 1	05	ADC 5

Table 3. Port Assignment Where Peripherals are Mapped into I/O Space (continued)

HEX PORT ADDRESS	PERIPHERAL	HEX PORT ADDRESS	PERIPHERAL
02	ADC 2	06	ADC 6
03	ADC 3	07	ADC 7

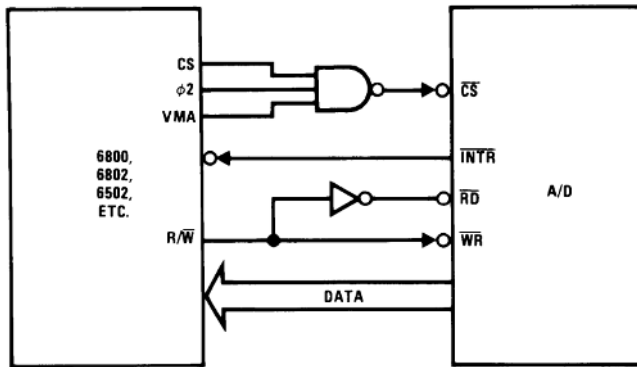
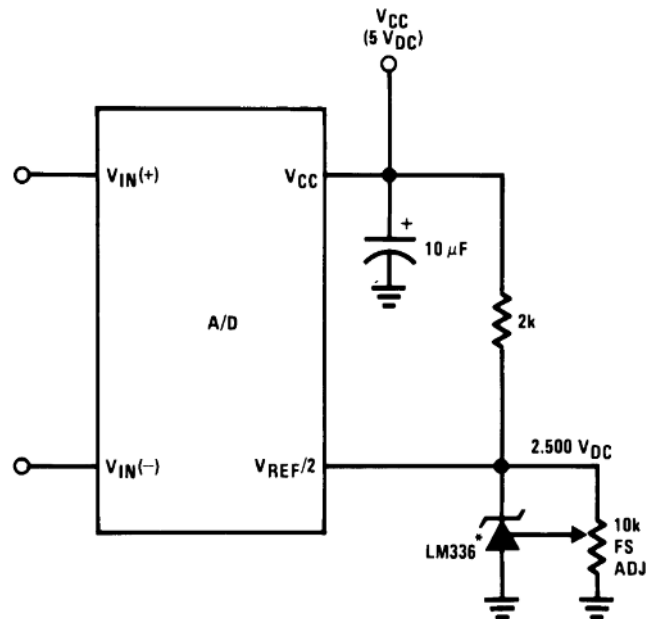
This port address also serves as the ADC identifying word in the program.


Figure 47. Multiple ADCs With Z-80 Type Microprocessor

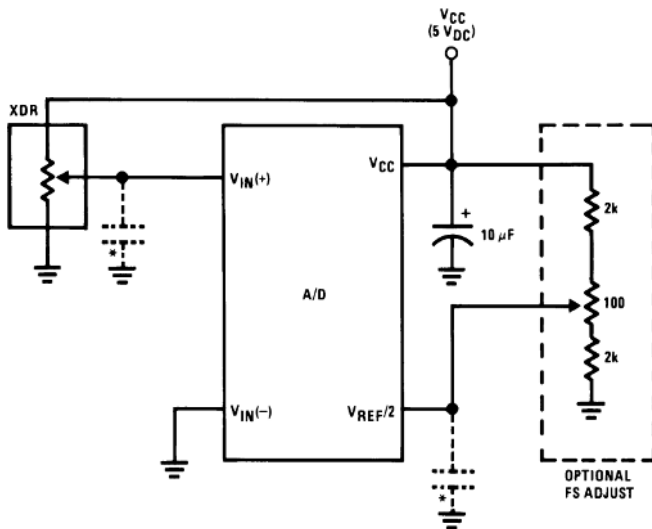
INTERRUPT SERVICING SUBROUTINE

LOC	OBJ CODE	SOURCE	STATEMENT	COMMENT
0038	E5		PUSH HL	; Save contents of all registers affected by
0039	C5		PUSH BC	; this subroutine.
003A	F5		PUSH AF	; Assumed INT mode 1 earlier set.
003B	21 00 3E		LD (HL), X3E00	; Initialize memory pointer where data will be stored.
003E	0E 01		LD C, X01	; C register will be port ADDR of A/D converters.
0040	D300		OUT X00, A	; Load peripheral status word into 8-bit latch.
0042	DB00		IN A, X00	; Load status word into accumulator.
0044	47		LD B, A	; Save the status word.
0045	79	TEST	LD A, C	; Test to see if the status of all A/D's have
0046	FE 08		CP, X08	; been checked. If so, exit subroutine
0048	CA 60 00		JPZ, DONE	
004B	78		LD A, B	; Test a single bit in status word by looking for
004C	1F		RRA	; a "1" to be rotated into the CARRY (an $\overline{\text{INT}}$
004D	47		LD B, A	; is loaded as a "1"). If CARRY is set then load
004E	DA 5500		JPC, LOAD	; contents of A/D at port ADDR in C register.
0051	0C	NEXT	INC C	; If CARRY is not set, increment C register to point
0052	C3 4500		JP, TEST	; to next A/D, then test next bit in status word.
0055	ED 78	LOAD	IN A, (C)	; Read data from interrupting A/D and invert
0057	EE FF		XOR FF	; the data.
0059	77		LD (HL), A	; Store the data
005A	2C		INC L	
005B	71		LD (HL), C	; Store A/D identifier (A/D port ADDR).
005C	2C		INC L	
005D	C3 51 00		JP, NEXT	; Test next bit in status word.
0060	F1	DONE	POP AF	; Re-establish all registers as they were
0061	C1		POP BC	; before the interrupt.
0062	E1		POP HL	
0063	C9		RET	; Return to original program

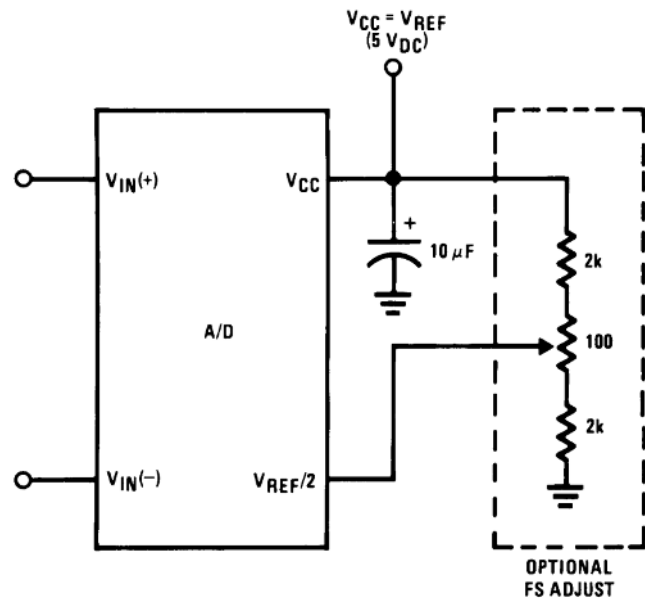
9.3 System Examples


Figure 48. 6800 Interface


*For low power, see also LM385–2.5

Figure 49. Absolute With a 2.5-V Reference


Note: before using caps at V_{IN} or $V_{REF/2}$, see section Input Bypass Capacitors.

Figure 50. Ratiometric With Full-Scale Adjust

Figure 51. Absolute With a 5-V Reference

System Examples (continued)

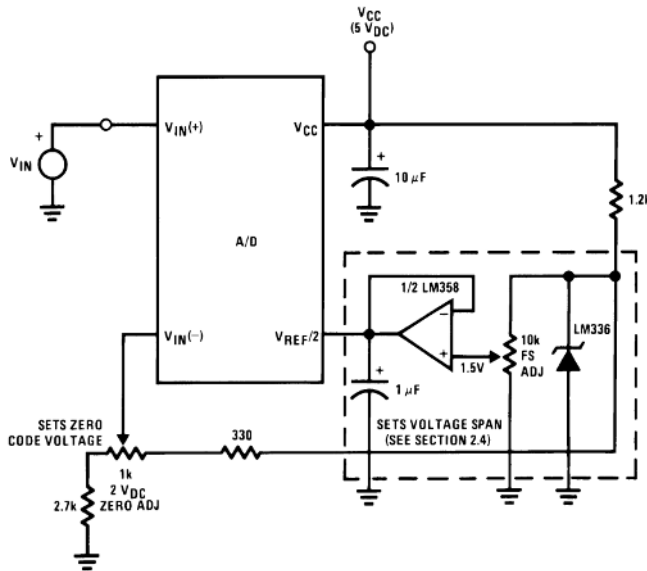


Figure 52. Zero-Shift and Span Adjust: $2\text{ V} \leq V_{IN} \leq 5\text{ V}$

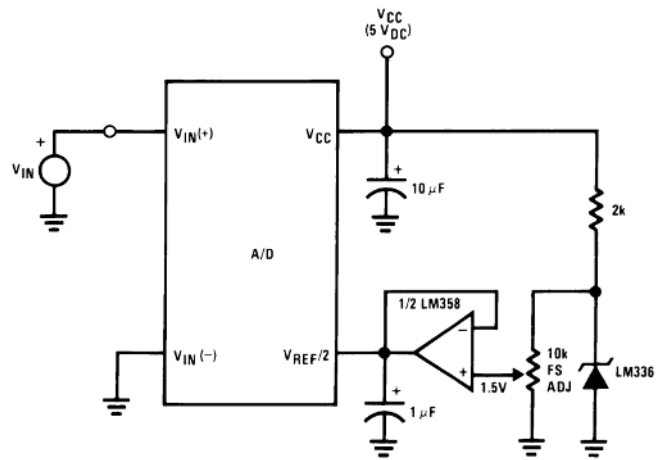


Figure 53. Span Adjust: $0\text{ V} \leq V_{IN} \leq 3\text{ V}$

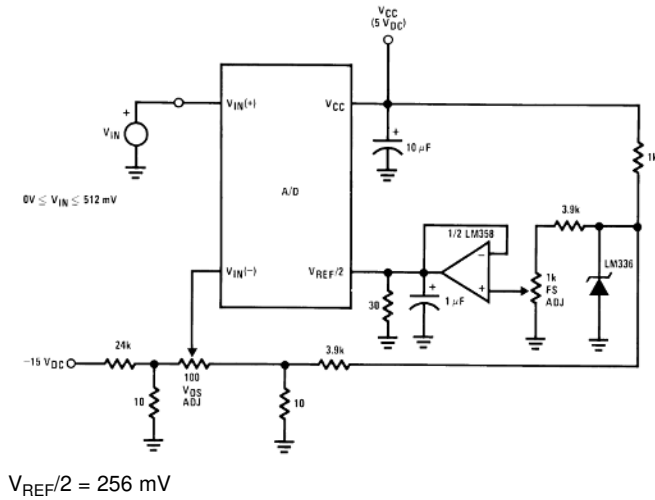
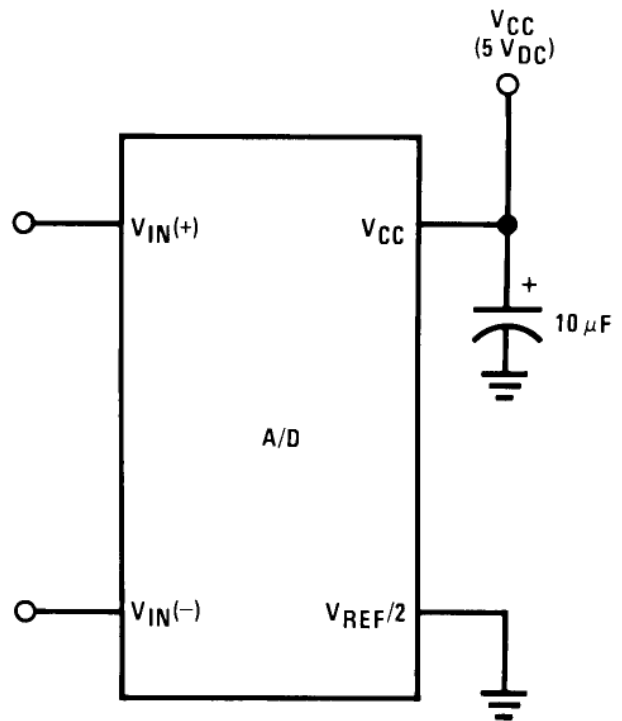


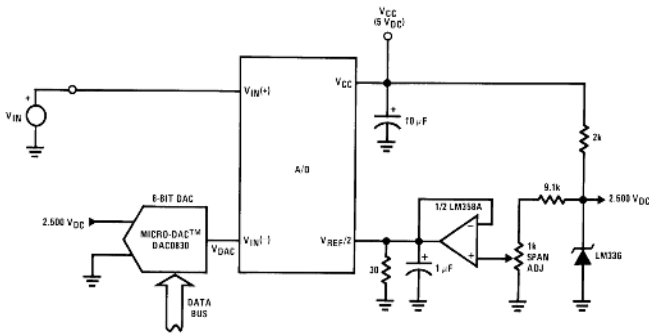
Figure 54. Directly Converting a Low-Level Signal



For: $V_{IN(+)} > V_{IN(-)}$; Output = FF_{HEX}
 For: $V_{IN(+)} < V_{IN(-)}$; Output = 00_{HEX}

Figure 55. A μ P Interfaced Comparator

System Examples (continued)



$V_{REF}/2=128\text{ mV}$; $1\text{ LSB}=1\text{ mV}$; $V_{DAC} \leq V_{IN} \leq (V_{DAC} + 256\text{ mV})$; $0 \leq V_{DAC} < 2.5\text{ V}$

Figure 56. 1-mV Resolution With μP -Controlled Range

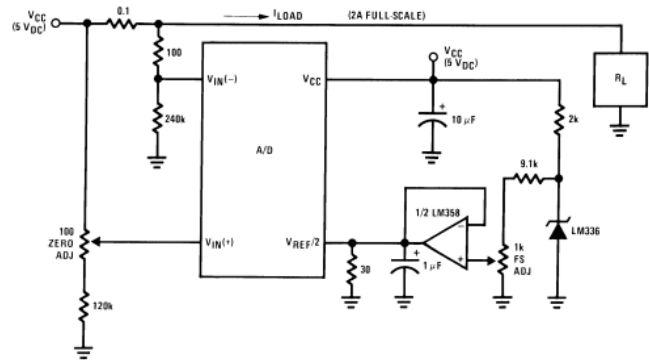
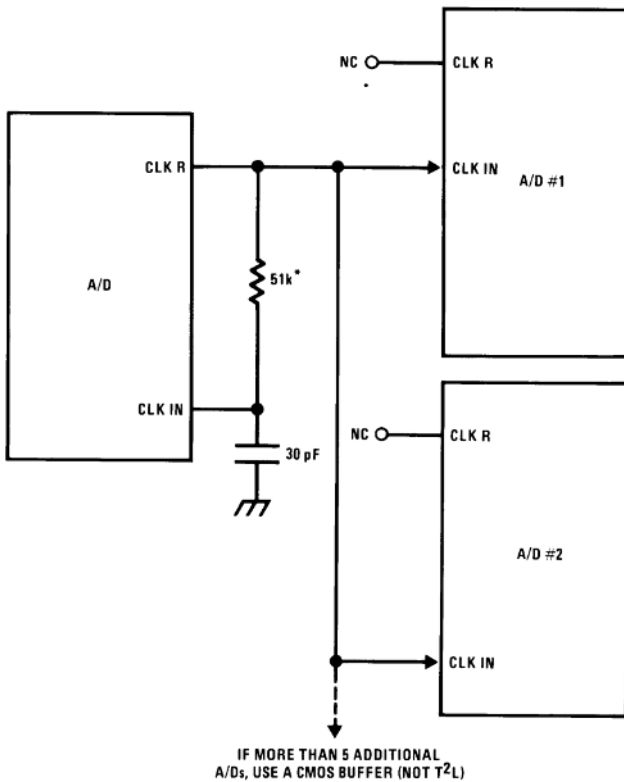
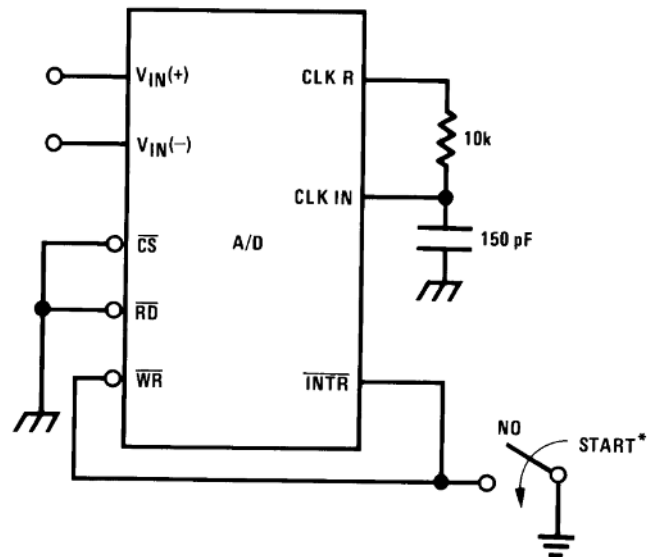


Figure 57. Digitizing a Current Flow



* Use a large R value to reduce loading at CLK R output.

Figure 58. Self-Clocking Multiple ADCs



*After power up, a momentary grounding of the WR input is needed to ensure operation.

Figure 59. Self-Clocking in Free-Running Mode

System Examples (continued)

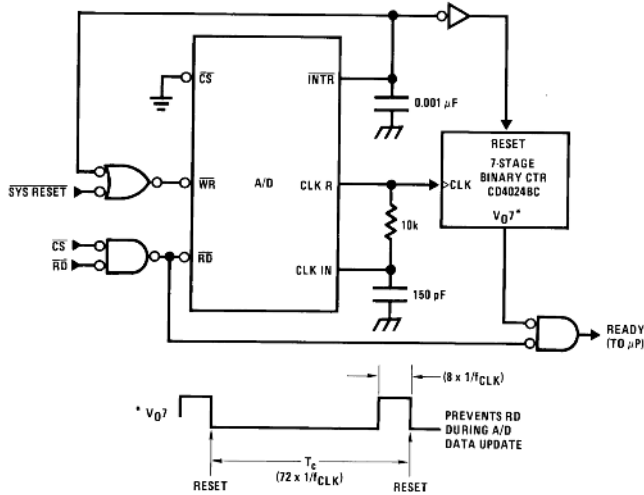
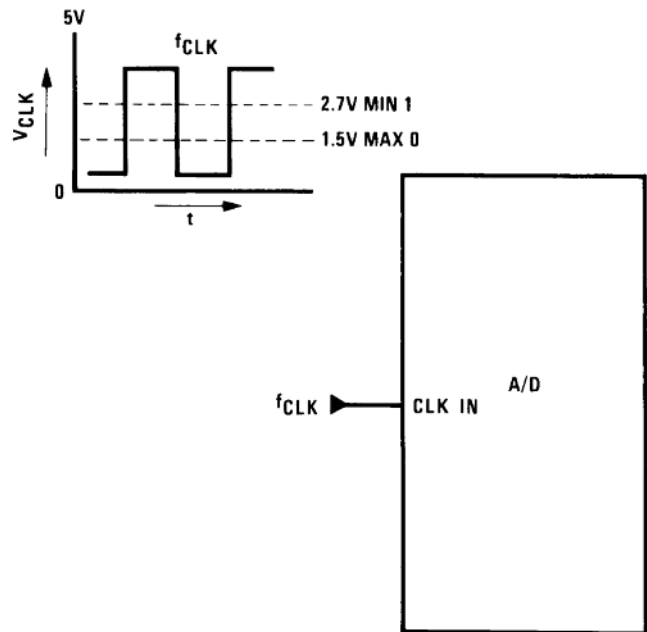
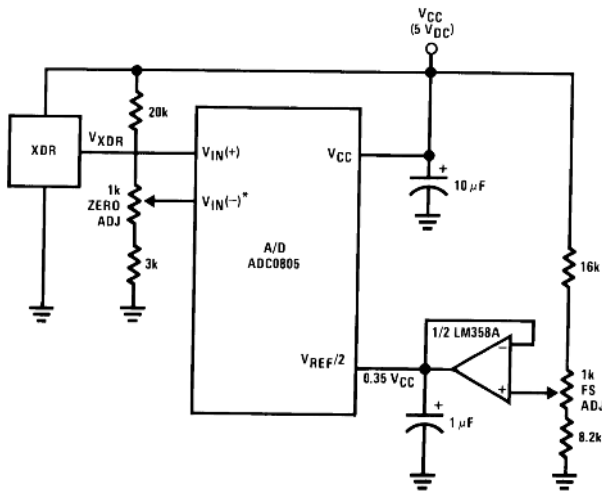


Figure 60. μ P Interface for Free-Running ADC



100 kHz \leq f_{CLK} \leq 1460 kHz

Figure 61. External clocking



* $V_{IN(-)} = 0.15 V_{CC}$
 $15\% \text{ of } V_{CC} \leq V_{XDR} \leq 85\% \text{ of } V_{CC}$

Figure 62. Operating With "Automotive" Ratiometric Transducers

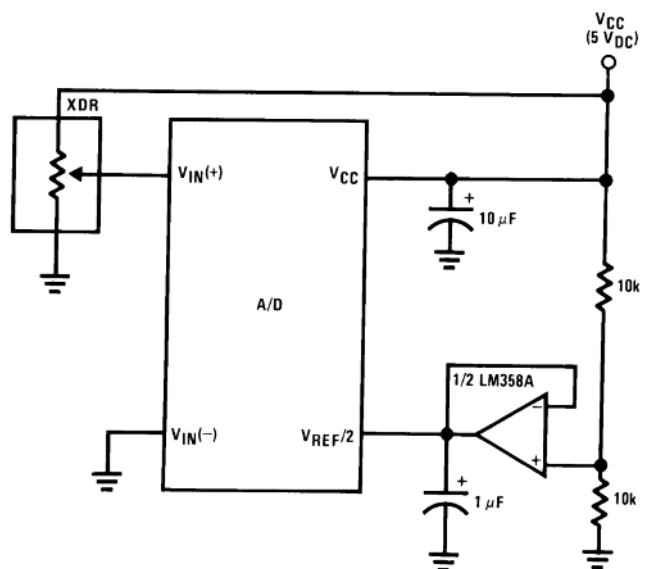
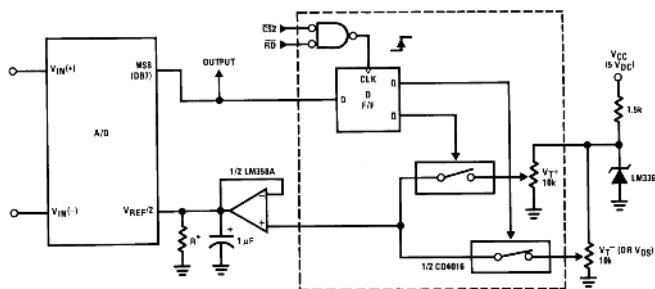


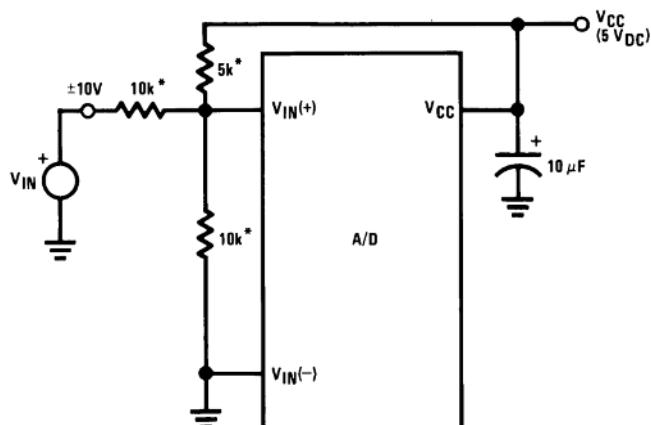
Figure 63. Ratiometric With $V_{REF/2}$ Forced

System Examples (continued)



*Select R value DB7 = "1" for $V_{IN(+)} > V_{IN(-)} + (V_{REF}/2)$. Omit circuitry within the dotted area if hysteresis is not needed.

Figure 64. μP-Compatible Differential-Input Comparator With Pre-Set VOS (With or Without Hysteresis)



*Beckman Instruments #694-3-R10K resistor array

Figure 65. Handling ±10-V Analog Inputs

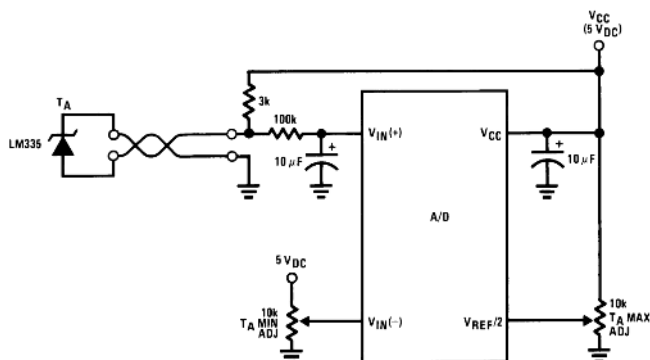
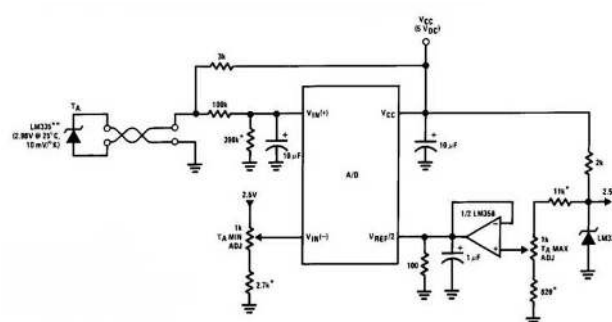


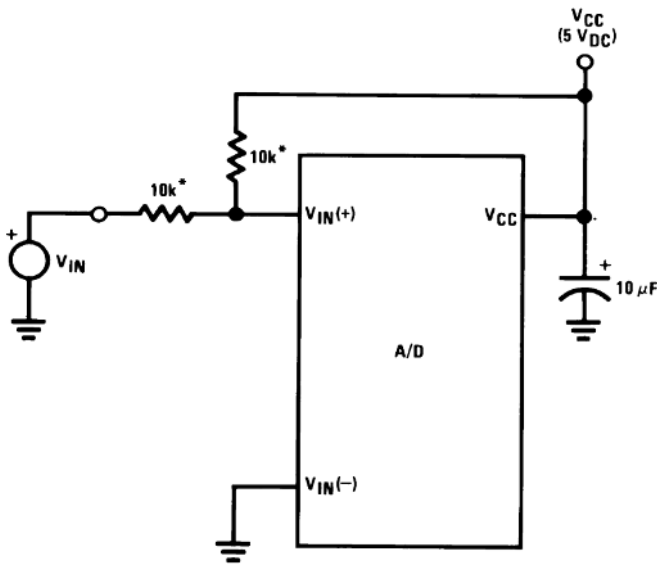
Figure 66. Low-Cost, μP-Interfaced, Temperature-to-Digital Converter



**Can calibrate each sensor to allow easy replacement, then ADC can be calibrated with a pre-set input voltage.

Figure 67. μP-Interfaced Temperature-to-Digital Converter

System Examples (continued)



*Beckman Instruments #694-3-R10K resistor array

Figure 68. Handling ± 5 -V Analog Inputs

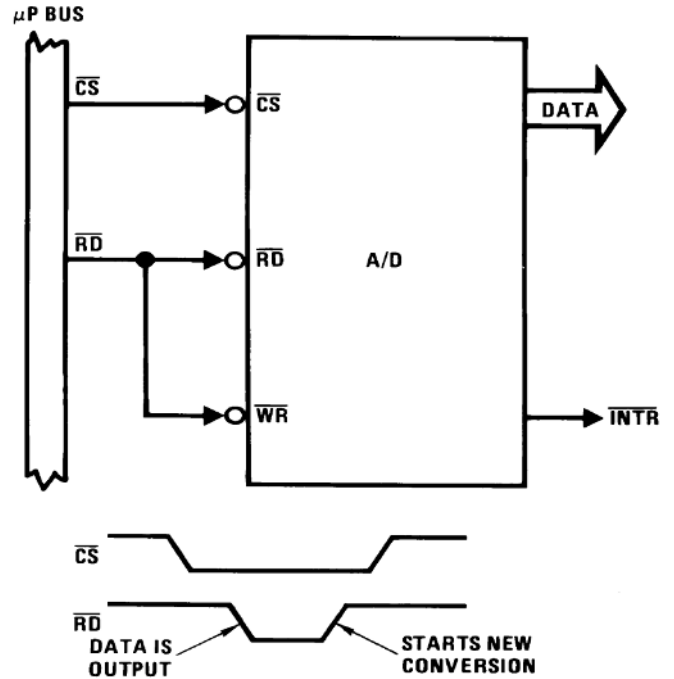


Figure 69. Read-Only Interface

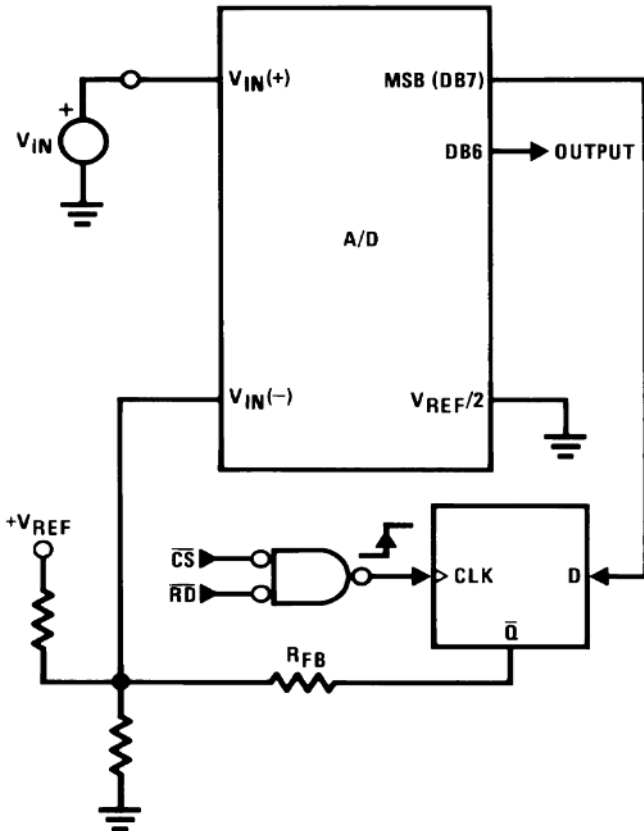
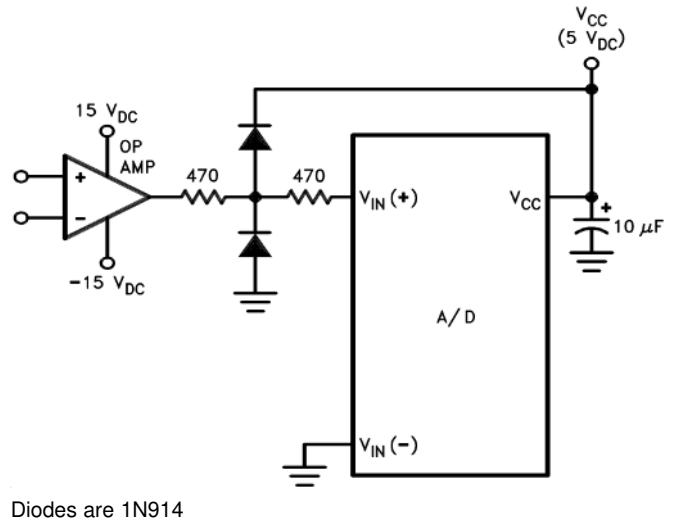


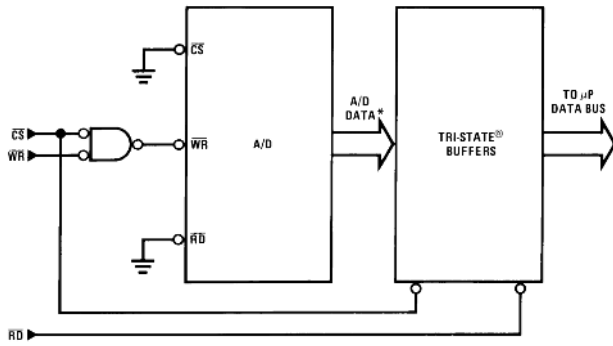
Figure 70. μP -Interfaced Comparator With Hysteresis



Diodes are 1N914

Figure 71. Protecting the Input

System Examples (continued)



*ADC output data is updated 1 CLK period prior to assertion of $\overline{\text{INTR}}$

Figure 76. Output Buffers With ADC Data Enabled

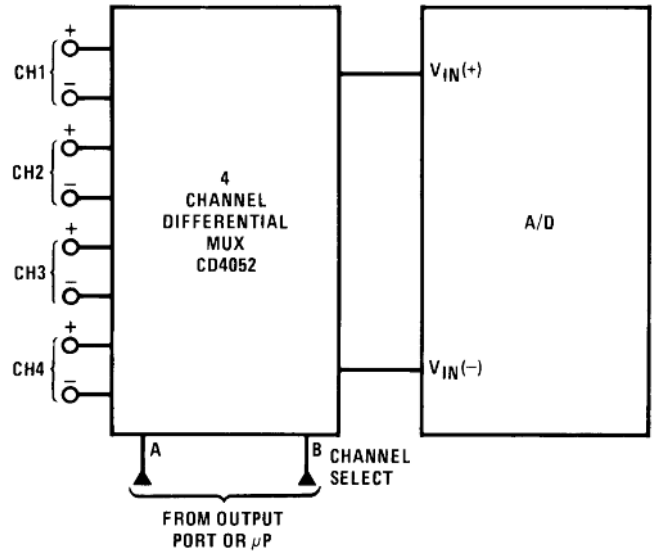
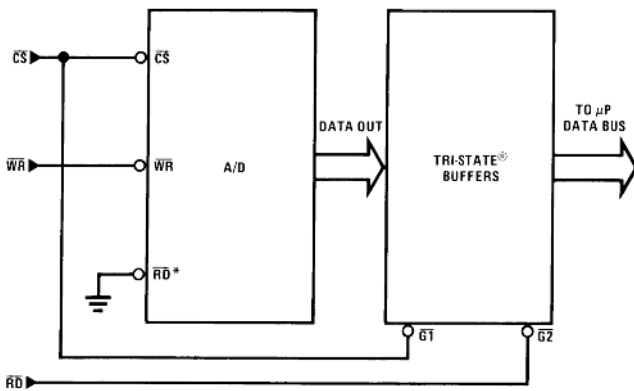
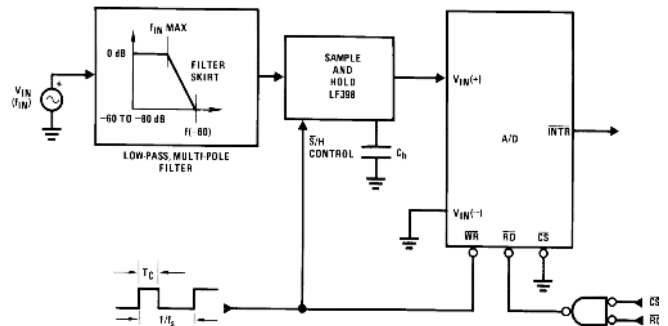


Figure 77. Multiplexing Differential Inputs



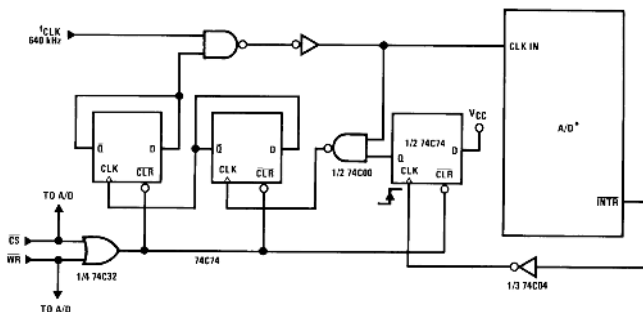
*Allows output data to set-up at falling edge of $\overline{\text{CS}}$

Figure 78. Increasing Bus Drive and/or Reducing Time on Bus



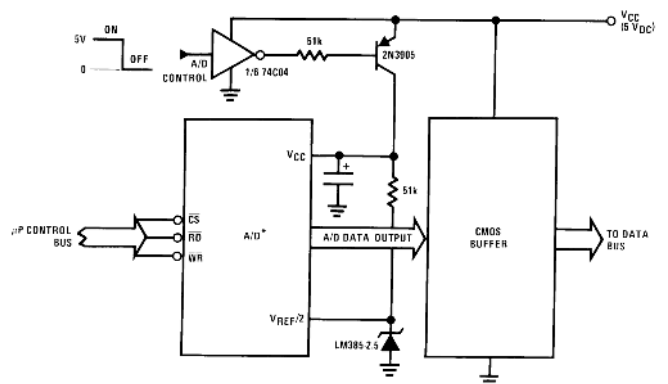
(2) Consider the amplitude errors which are introduced within the passband of the filter.

Figure 79. Sampling an AC Input Signal



(Complete shutdown takes \approx 30 seconds.)

Figure 80. 70% Power Savings by Clock Gating



Buffer prevents data bus from overdriving output of ADC when in shutdown mode.

Figure 81. Power Savings by ADC and V_{REF} Shutdown

10 Power Supply Recommendations

Precautions should be taken to insure that the power supply for the integrated circuit never becomes reversed in polarity or that the unit is not inadvertently installed backwards in a test socket as an unlimited current surge through the resulting forward diode within the device could cause fusing of the internal conductors and result in a destroyed unit.

Noise spikes on the V_{CC} supply line can cause conversion errors as the comparator will respond to this noise. A low-inductance, low-ESR tantalum bypass capacitor should be used close to the converter VCC pin, and a 10- μ F is recommended. If an unregulated voltage is available in the system, a separate 5-V voltage regulator for the converter (and other analog circuitry) will greatly reduce digital noise on the V_{CC} supply.

11 Layout

11.1 Layout Guidelines

All logic signal wires and leads should be grouped and kept as far away as possible from the analog signal leads. Exposed leads to the analog inputs can cause undesired digital noise and 60-Hz pickup. Shielded leads for the analog inputs may be required in sensitive applications. A single-point analog ground should be used that is also separated from the logic ground points. The power supply bypass capacitor should be returned to digital ground. Any $V_{REF}/2$ bypass capacitors, analog input filter capacitors, or input signal shielding should be returned to the analog ground point. A test for proper grounding is to measure the zero error of the ADC converter. Zero errors in excess of 1/4 LSB is generally traceable to improper PCB layout and/or wiring.

To minimize potential offset issues, TI recommends to route the signal traces differentially next to each other so that they will see the same thermal gradients and the same number of feedthroughs. Furthermore, inductance is determined by the size of the loop of current. Providing a path for return currents next to the signal trace will reduce the inductance. A solid ground plane is very advantageous in this regard. Ensure to minimize the loop area formed by the bypass capacitor connection between V_{CC} and ground. The ground pin should be connected to the PCB ground plane at the pin of the device.

12 Device and Documentation Support

12.1 Related Links

The table below lists quick access links. Categories include technical documents, support and community resources, tools and software, and quick access to sample or buy.

Table 4. Related Links

PARTS	PRODUCT FOLDER	SAMPLE & BUY	TECHNICAL DOCUMENTS	TOOLS & SOFTWARE	SUPPORT & COMMUNITY
ADC0801	Click here	Click here	Click here	Click here	Click here
ADC0802	Click here	Click here	Click here	Click here	Click here
ADC0803	Click here	Click here	Click here	Click here	Click here
ADC0804	Click here	Click here	Click here	Click here	Click here
ADC0805	Click here	Click here	Click here	Click here	Click here

12.2 Community Resources

The following links connect to TI community resources. Linked contents are provided "AS IS" by the respective contributors. They do not constitute TI specifications and do not necessarily reflect TI's views; see TI's [Terms of Use](#).

TI E2E™ Online Community *TI's Engineer-to-Engineer (E2E) Community*. Created to foster collaboration among engineers. At e2e.ti.com, you can ask questions, share knowledge, explore ideas and help solve problems with fellow engineers.

Design Support *TI's Design Support* Quickly find helpful E2E forums along with design support tools and contact information for technical support.

12.3 Trademarks

E2E is a trademark of Texas Instruments.
All other trademarks are the property of their respective owners.

12.4 Electrostatic Discharge Caution



These devices have limited built-in ESD protection. The leads should be shorted together or the device placed in conductive foam during storage or handling to prevent electrostatic damage to the MOS gates.

12.5 Glossary

SLYZ022 — *TI Glossary*.

This glossary lists and explains terms, acronyms, and definitions.

13 Mechanical, Packaging, and Orderable Information

The following pages include mechanical, packaging, and orderable information. This information is the most current data available for the designated devices. This data is subject to change without notice and revision of this document. For browser-based versions of this data sheet, refer to the left-hand navigation.

PACKAGING INFORMATION

Orderable Device	Status (1)	Package Type	Package Drawing	Pins	Package Qty	Eco Plan (2)	Lead/Ball Finish (6)	MSL Peak Temp (3)	Op Temp (°C)	Device Marking (4/5)	Samples
ADC0801LCN/NOPB	LIFEBUY	PDIP	NFH	20	18	Pb-Free (RoHS)	SN	Level-1-NA-UNLIM	-40 to 85	ADC0801LCN	
ADC0802LCN	NRND	PDIP	NFH	20	18	TBD	Call TI	Call TI	-40 to 85	ADC0802LCN	
ADC0802LCN/NOPB	ACTIVE	PDIP	NFH	20	18	Green (RoHS & no Sb/Br)	CU SN	Level-1-NA-UNLIM	-40 to 85	ADC0802LCN	
ADC0802LCWM/NOPB	ACTIVE	SOIC	DW	20	36	Green (RoHS & no Sb/Br)	CU SN	Level-3-260C-168 HR	-40 to 85	ADC0802 LCWM	
ADC0803LCN	NRND	PDIP	NFH	20	18	TBD	Call TI	Call TI	-40 to 85	ADC0803LCN	
ADC0803LCN/NOPB	ACTIVE	PDIP	NFH	20	18	Pb-Free (RoHS)	CU SN	Level-1-NA-UNLIM	-40 to 85	ADC0803LCN	
ADC0804LCN	NRND	PDIP	NFH	20	18	TBD	Call TI	Call TI	-40 to 85	ADC0804LCN	
ADC0804LCN/NOPB	ACTIVE	PDIP	NFH	20	18	Green (RoHS & no Sb/Br)	CU SN	Level-1-NA-UNLIM	-40 to 85	ADC0804LCN	
ADC0804LCWM	NRND	SOIC	DW	20	36	TBD	Call TI	Call TI	-40 to 85	ADC0804 LCWM	
ADC0804LCWM/NOPB	ACTIVE	SOIC	DW	20	36	Green (RoHS & no Sb/Br)	CU SN	Level-3-260C-168 HR	-40 to 85	ADC0804 LCWM	
ADC0804LCWMX	NRND	SOIC	DW	20	1000	TBD	Call TI	Call TI	-40 to 85	ADC0804 LCWM	
ADC0804LCWMX/NOPB	ACTIVE	SOIC	DW	20	1000	Green (RoHS & no Sb/Br)	CU SN	Level-3-260C-168 HR	-40 to 85	ADC0804 LCWM	

(1) The marketing status values are defined as follows:

ACTIVE: Product device recommended for new designs.

LIFEBUY: TI has announced that the device will be discontinued, and a lifetime-buy period is in effect.

NRND: Not recommended for new designs. Device is in production to support existing customers, but TI does not recommend using this part in a new design.

PREVIEW: Device has been announced but is not in production. Samples may or may not be available.

OBSELETE: TI has discontinued the production of the device.

(2) Eco Plan - The planned eco-friendly classification: Pb-Free (RoHS), Pb-Free (RoHS Exempt), or Green (RoHS & no Sb/Br) - please check <http://www.ti.com/productcontent> for the latest availability information and additional product content details.

TBD: The Pb-Free/Green conversion plan has not been defined.

Pb-Free (RoHS): TI's terms "Lead-Free" or "Pb-Free" mean semiconductor products that are compatible with the current RoHS requirements for all 6 substances, including the requirement that lead not exceed 0.1% by weight in homogeneous materials. Where designed to be soldered at high temperatures, TI Pb-Free products are suitable for use in specified lead-free processes.

Pb-Free (RoHS Exempt): This component has a RoHS exemption for either 1) lead-based flip-chip solder bumps used between the die and package, or 2) lead-based die adhesive used between the die and leadframe. The component is otherwise considered Pb-Free (RoHS compatible) as defined above.

Green (RoHS & no Sb/Br): TI defines "Green" to mean Pb-Free (RoHS compatible), and free of Bromine (Br) and Antimony (Sb) based flame retardants (Br or Sb do not exceed 0.1% by weight in homogeneous material)

(3) MSL, Peak Temp. - The Moisture Sensitivity Level rating according to the JEDEC industry standard classifications, and peak solder temperature.

(4) There may be additional marking, which relates to the logo, the lot trace code information, or the environmental category on the device.

(5) Multiple Device Markings will be inside parentheses. Only one Device Marking contained in parentheses and separated by a "~" will appear on a device. If a line is indented then it is a continuation of the previous line and the two combined represent the entire Device Marking for that device.

(6) Lead/Ball Finish - Orderable Devices may have multiple material finish options. Finish options are separated by a vertical ruled line. Lead/Ball Finish values may wrap to two lines if the finish value exceeds the maximum column width.

Important Information and Disclaimer: The information provided on this page represents TI's knowledge and belief as of the date that it is provided. TI bases its knowledge and belief on information provided by third parties, and makes no representation or warranty as to the accuracy of such information. Efforts are underway to better integrate information from third parties. TI has taken and continues to take reasonable steps to provide representative and accurate information but may not have conducted destructive testing or chemical analysis on incoming materials and chemicals. TI and TI suppliers consider certain information to be proprietary, and thus CAS numbers and other limited information may not be available for release.

In no event shall TI's liability arising out of such information exceed the total purchase price of the TI part(s) at issue in this document sold by TI to Customer on an annual basis.

TAPE AND REEL INFORMATION



QUADRANT ASSIGNMENTS FOR PIN 1 ORIENTATION IN TAPE



*All dimensions are nominal

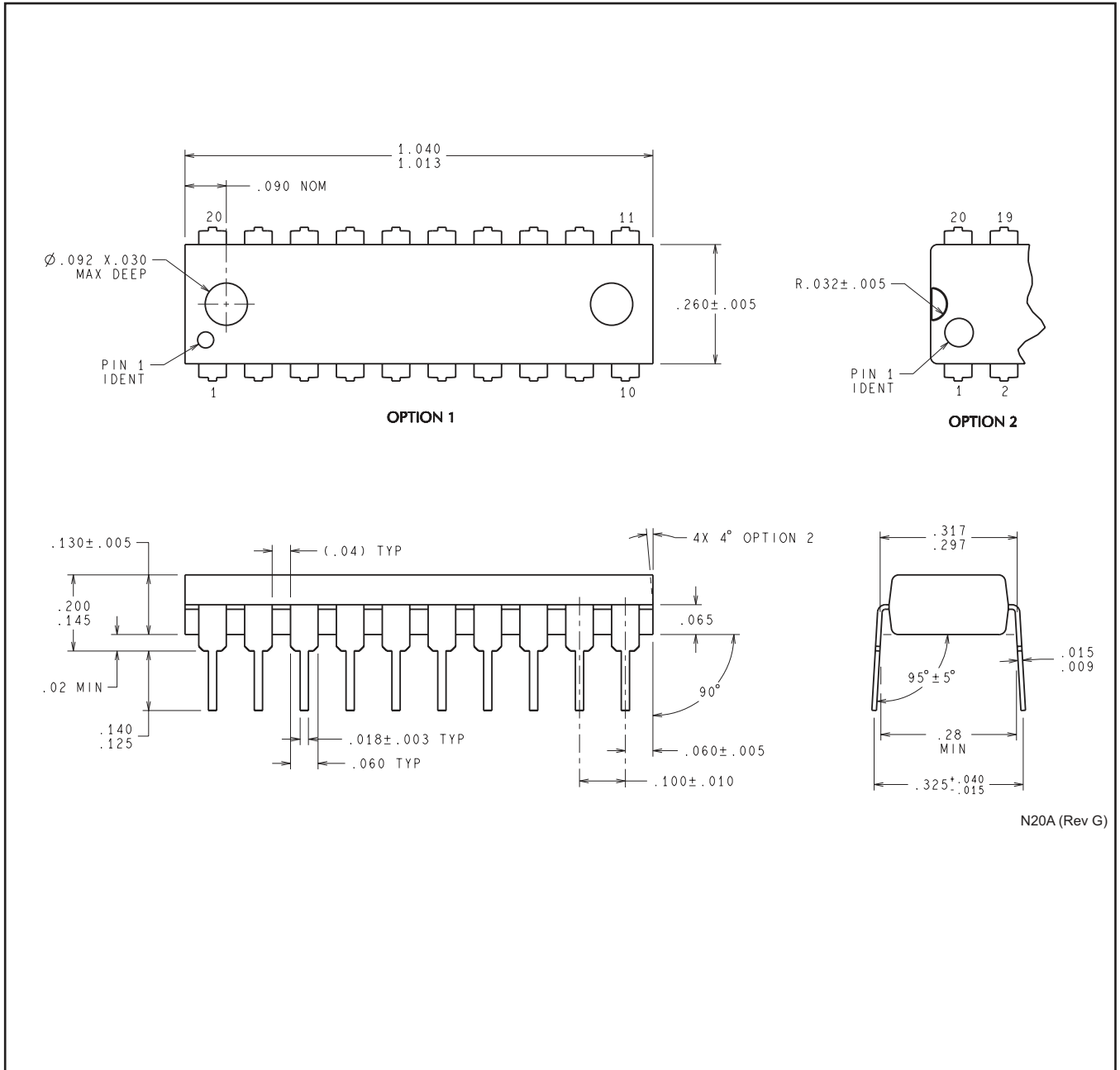
Device	Package Type	Package Drawing	Pins	SPQ	Reel Diameter (mm)	Reel Width W1 (mm)	A0 (mm)	B0 (mm)	K0 (mm)	P1 (mm)	W (mm)	Pin1 Quadrant
ADC0804LCWMX	SOIC	DW	20	1000	330.0	24.4	10.9	13.3	3.25	12.0	24.0	Q1
ADC0804LCWMX/NOPB	SOIC	DW	20	1000	330.0	24.4	10.9	13.3	3.25	12.0	24.0	Q1

TAPE AND REEL BOX DIMENSIONS


*All dimensions are nominal

Device	Package Type	Package Drawing	Pins	SPQ	Length (mm)	Width (mm)	Height (mm)
ADC0804LCWMX	SOIC	DW	20	1000	367.0	367.0	45.0
ADC0804LCWMX/NOPB	SOIC	DW	20	1000	367.0	367.0	45.0

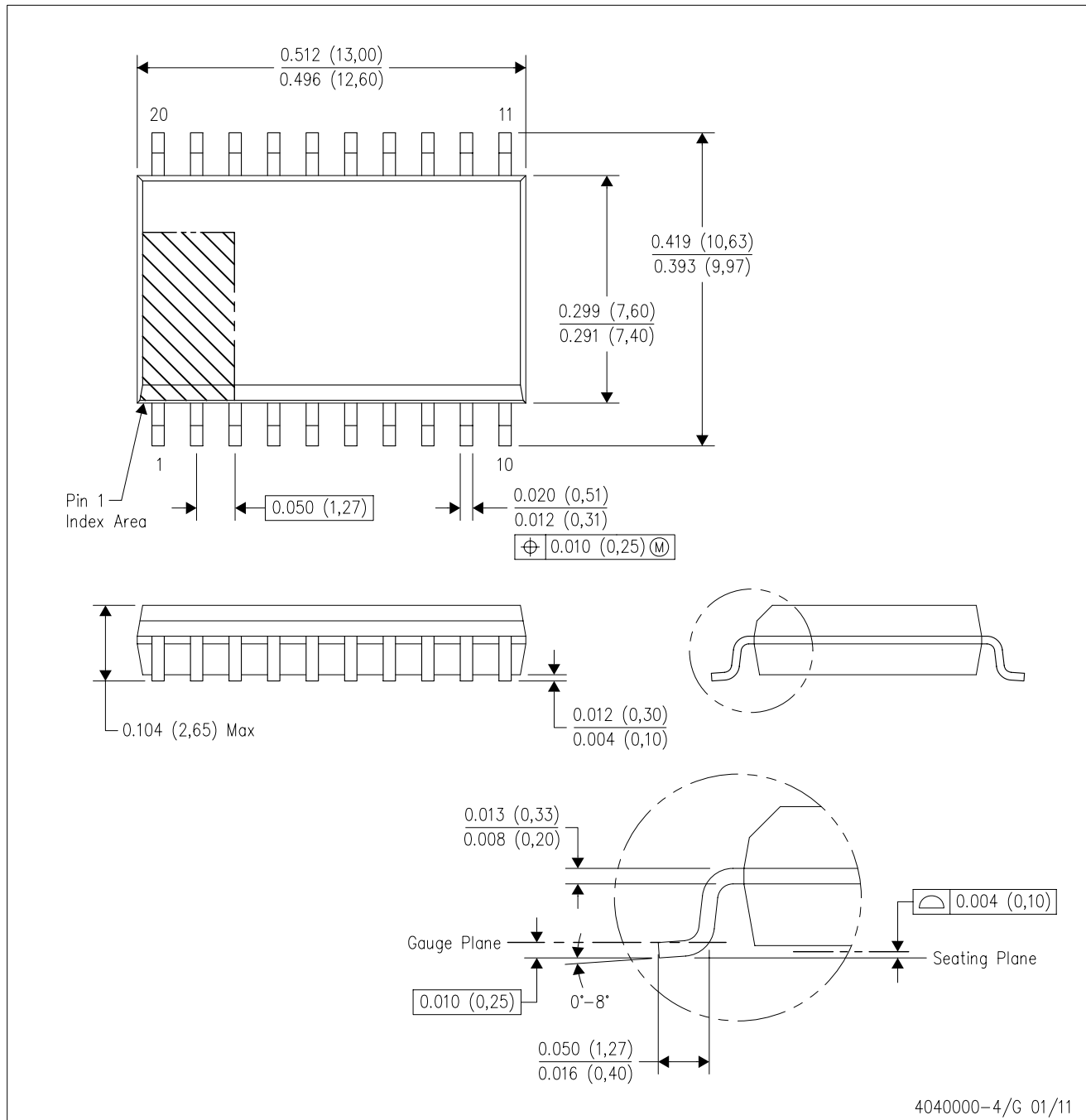
NFH0020A



N20A (Rev G)

DW (R-PDSO-G20)

PLASTIC SMALL OUTLINE



- NOTES:
- A. All linear dimensions are in inches (millimeters). Dimensioning and tolerancing per ASME Y14.5M-1994.
 - B. This drawing is subject to change without notice.
 - C. Body dimensions do not include mold flash or protrusion not to exceed 0.006 (0,15).
 - D. Falls within JEDEC MS-013 variation AC.

IMPORTANT NOTICE

Texas Instruments Incorporated and its subsidiaries (TI) reserve the right to make corrections, enhancements, improvements and other changes to its semiconductor products and services per JESD46, latest issue, and to discontinue any product or service per JESD48, latest issue. Buyers should obtain the latest relevant information before placing orders and should verify that such information is current and complete. All semiconductor products (also referred to herein as "components") are sold subject to TI's terms and conditions of sale supplied at the time of order acknowledgment.

TI warrants performance of its components to the specifications applicable at the time of sale, in accordance with the warranty in TI's terms and conditions of sale of semiconductor products. Testing and other quality control techniques are used to the extent TI deems necessary to support this warranty. Except where mandated by applicable law, testing of all parameters of each component is not necessarily performed.

TI assumes no liability for applications assistance or the design of Buyers' products. Buyers are responsible for their products and applications using TI components. To minimize the risks associated with Buyers' products and applications, Buyers should provide adequate design and operating safeguards.

TI does not warrant or represent that any license, either express or implied, is granted under any patent right, copyright, mask work right, or other intellectual property right relating to any combination, machine, or process in which TI components or services are used. Information published by TI regarding third-party products or services does not constitute a license to use such products or services or a warranty or endorsement thereof. Use of such information may require a license from a third party under the patents or other intellectual property of the third party, or a license from TI under the patents or other intellectual property of TI.

Reproduction of significant portions of TI information in TI data books or data sheets is permissible only if reproduction is without alteration and is accompanied by all associated warranties, conditions, limitations, and notices. TI is not responsible or liable for such altered documentation. Information of third parties may be subject to additional restrictions.

Resale of TI components or services with statements different from or beyond the parameters stated by TI for that component or service voids all express and any implied warranties for the associated TI component or service and is an unfair and deceptive business practice. TI is not responsible or liable for any such statements.

Buyer acknowledges and agrees that it is solely responsible for compliance with all legal, regulatory and safety-related requirements concerning its products, and any use of TI components in its applications, notwithstanding any applications-related information or support that may be provided by TI. Buyer represents and agrees that it has all the necessary expertise to create and implement safeguards which anticipate dangerous consequences of failures, monitor failures and their consequences, lessen the likelihood of failures that might cause harm and take appropriate remedial actions. Buyer will fully indemnify TI and its representatives against any damages arising out of the use of any TI components in safety-critical applications.

In some cases, TI components may be promoted specifically to facilitate safety-related applications. With such components, TI's goal is to help enable customers to design and create their own end-product solutions that meet applicable functional safety standards and requirements. Nonetheless, such components are subject to these terms.

No TI components are authorized for use in FDA Class III (or similar life-critical medical equipment) unless authorized officers of the parties have executed a special agreement specifically governing such use.

Only those TI components which TI has specifically designated as military grade or "enhanced plastic" are designed and intended for use in military/aerospace applications or environments. Buyer acknowledges and agrees that any military or aerospace use of TI components which have **not** been so designated is solely at the Buyer's risk, and that Buyer is solely responsible for compliance with all legal and regulatory requirements in connection with such use.

TI has specifically designated certain components as meeting ISO/TS16949 requirements, mainly for automotive use. In any case of use of non-designated products, TI will not be responsible for any failure to meet ISO/TS16949.

Products

Audio	www.ti.com/audio
Amplifiers	amplifier.ti.com
Data Converters	dataconverter.ti.com
DLP® Products	www.dlp.com
DSP	dsp.ti.com
Clocks and Timers	www.ti.com/clocks
Interface	interface.ti.com
Logic	logic.ti.com
Power Mgmt	power.ti.com
Microcontrollers	microcontroller.ti.com
RFID	www.ti-rfid.com
OMAP Applications Processors	www.ti.com/omap
Wireless Connectivity	www.ti.com/wirelessconnectivity

Applications

Automotive and Transportation	www.ti.com/automotive
Communications and Telecom	www.ti.com/communications
Computers and Peripherals	www.ti.com/computers
Consumer Electronics	www.ti.com/consumer-apps
Energy and Lighting	www.ti.com/energy
Industrial	www.ti.com/industrial
Medical	www.ti.com/medical
Security	www.ti.com/security
Space, Avionics and Defense	www.ti.com/space-avionics-defense
Video and Imaging	www.ti.com/video

TI E2E Community

e2e.ti.com