



General features

- Supports 1.5Mbps and 12Mbps serial data transmission
- ESD HBM: $\pm 14\text{kV}$ on D+, D- Lines; $\pm 5\text{kV}$ on VBUS
- ESD Compliant to IEC-61000-4.2 (Level 3)
- Separate I/O supply with operation down to 1.6V
- Integrated speed select termination supply
- Very low power consumption to meet USB 'suspend' current requirements
- Small QFN16 lead free package
- No power supply sequencing requirements
- Software controlled re-enumeration

Description

The STUSB02E is a single chip USB transceiver that supports both full-speed (12Mbps) and low-speed (1.5Mbps) operation. It has an integrated 5V to 3.3V regulator which allows direct powering from the V_{BUS} . The transceiver has an integrated voltage detector to detect the presence of the V_{BUS} voltage.



The transceiver also supports Sharing mode when V_{BUS} is not present, which allows the D+/D- lines to be shared with other serial protocols.

It is also designed to operate down to 1.6V so that it is compatible with lower system voltages of most portable systems, which include PDAs, MP3 Player and Cell phones.

Order code

Part number	Package	Packaging
STUSB02EQR	QFN16 (3mm x 3mm)	3000 parts per reel

Contents

1	Typical application	3
2	Pin configuration	4
3	Functional tables	5
4	Maximum ratings	6
5	Electrical characteristics	7
6	Timing diagram	11
7	Test circuits	13
8	Functional description	15
9	Package mechanical data	16
10	Revision history	19

1 Typical application

Figure 1. Typical application

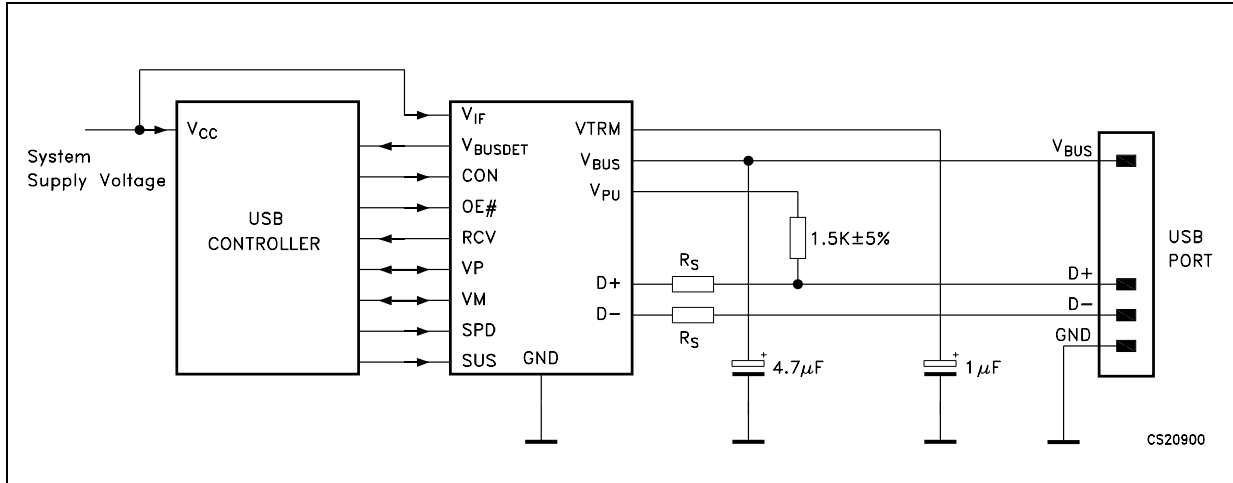

2 Pin configuration

Figure 2. Pin connections (top view)

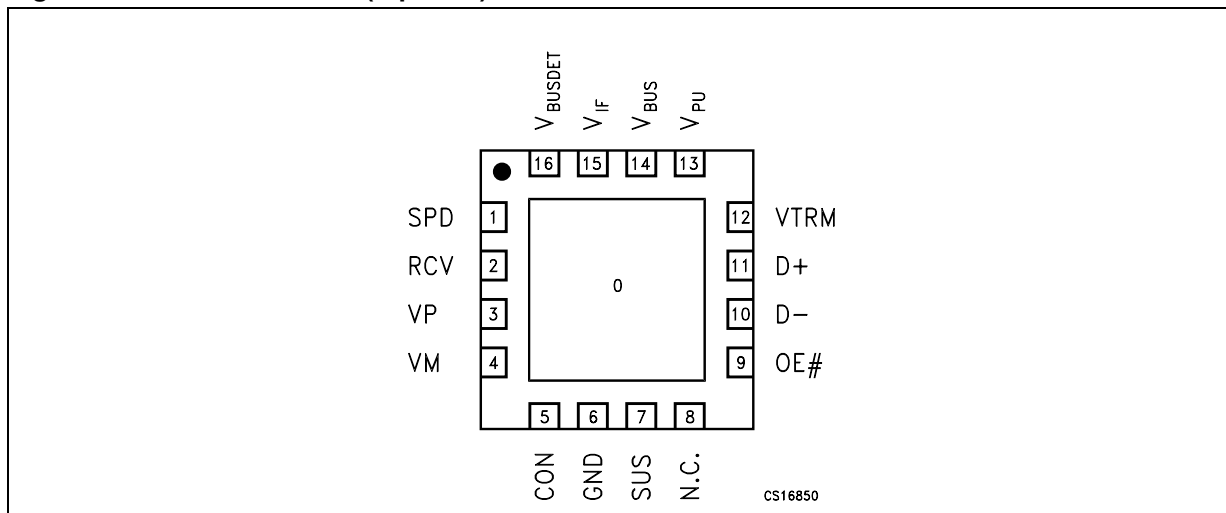

Table 1. Pin description

PIN N°	SYMBOL	I/O	NAME AND FUNCTION
0	N.C.		Not Connected.
15	V _{IF}	I	System Interface Supply Voltage (1.6V to 3.6V). Provides reference supply voltage for system I/O interface signals.
1	SPD	I	Edge Rate Control. A logic HIGH operates at edge rates for “fullspeed” operation. A logic LOW operates edge rates for “lowspeed” operation.
2	RCV	O	Receive Data. Output for USB differential data. (see Table 2)
3	VP	I/O	If OE# = H, VP = Receiver output (+) If OE# = L, VP = Driver input (+) (see Table 2)
4	VM	I/O	If OE# = H, VM = Receiver output (-) If OE# = L, VM = Driver input (-) (see Table 2)
5	CON	I	CONNECT (input). Controls state of V _{PU} . Refer to V _{PU} pin description for detail.
6	GND		Ground Reference
7	SUS	I	Suspend (active-high). Turns off internal circuits to reduce supply current.
9	OE#	I	Output Enable (active-low). Enables transceiver data transmission onto the bus. When not active, the transceiver is in the receive mode. (see Table 2)
10, 11	D-, D+	I/O	Differential data lines. (see Table 2)
12	VTRM	O	3.3V Reference Supply Output. Requires a 1.0µF decoupling capacitor for stability.
13	V _{PU}	O	Pull-up Supply Voltage Output. Used to connect 1.5kΩ pull-up speed detect resistor. If CON = 0, V _{PU} is high impedance. If CON = 1, V _{PU} = 3.3V ±10%.
14	V _{BUS}	I	USB Bus Supply Voltage (4V to 5.5V). Supplies power to the USB transceiver and internal circuitry.
8	N.C.		Not connected.
16	V _{BUSDET}	O	V _{BUS} indicator output. When V _{BUS} > 2.9V, V _{BUSDET} = High and when < 2.2V, V _{BUSDET} = Low.

3 Functional tables

Table 2. Function selection

SUS	OE#	D+, D-	RCV	VP/VM	Function
L	L	Driving	Active	Active	Normal transmit mode
L	H	Receiving	Active	Active	Normal receive mode
H	L	Hi-Z	L	Not Active	Low power state
H	H	Hi-Z	L	Active	Receiving during suspend (low power state) ⁽¹⁾

(1) During suspend VP and VM are active in order to detect out of band signalling conditions

Table 3. Truth table during normal mode

OE# = L					
Input		Output			RESULT
VP	VM	D+	D-	RCV	
L	L	L	L	X	SE0
L	H	L	H	L	Logic Low
H	L	H	L	H	Logic High
H	H	X	X	X	Undefined
OE# = H					
Input		Output			Result
D+	D-	VP	VM	RCV	
L	L	L	L	X	SE0
L	H	L	H	L	Logic Low
H	L	H	L	H	Logic High
H	H	X	X	X	Undefined

X = Undefined

4 Maximum ratings

Table 4. Absolute maximum ratings

Symbol	Parameter	Value	Unit
V_{BUS}	Supply voltage	6	V
$V+$	All other Inputs	-0.5 to 4.6	V
I_O	Output current (D+, D-)	± 50	mA
I_O	Output current (all others)	± 15	mA
I_I	Input current	± 50	mA
ESD	D+, D-, HBM (Note 3)	± 14	kV
	V_{BUS} (Note 3)	± 5	
	All other pins (Note 3)	± 2	
T_{STG}	Storage temperature range	-65 to + 150	°C
T_{OPR}	Operating temperature range	-40 to + 85	°C

Absolute Maximum Ratings are those values beyond which damage to the device may occur. Functional Operation under these conditions is not implied.

Note 3. Devices are ESD sensitive. Handling precautions recommended. Human body model, 1.5k Ω in series with 100pF.

Table 5. Thermal data

Symbol	Parameter	Value	Unit
R_{thJA}	Thermal resistance junction-ambient	59	°C/W

5 Electrical characteristics

Table 6. DC electrical characteristics (System and USB interface)

($V_{IF} = 3.6V$, $V_{BUS} = 5V$ unless otherwise noted; $T_A = 25^\circ C$, specifications over temperature, -40 to $85^\circ C$)

Symbol	Parameter	Test conditions	Min.	Typ.	Max.	Unit
V_{BUS}	USB Supply voltage		4		5.5	V
V_{IF}	System I/F supply voltage		1.6		3.6	V
V_{IL}	Low level input voltage (Note 4)				$0.15V_{IF}$	V
V_{IH}	High level input voltage (Note 4)		$0.85V_{IF}$			V
V_{OL}	Low level output voltage (Note 4)	$I_{OL} = 20\mu A$	0		100	mV
V_{OH}	High level output voltage (Note 4)	$I_{OH} = -20\mu A$	$V_{IF}-100$		V_{IF}	mV
I_{IL}	Input leakage current (Note 4)		-5		5	μA
I_{IF}	V_{IF} Supply current (Note 7)	D+, D- are idle, OE# = SUS = 0			5	μA
		D+, D- are idle, OE# = SUS = 1			5	
		D+, D- active, $C_{LOAD} = 50pF$, SPD = 1, f = 6MHz, (Note 5)			650	
		D+, D- active, $C_{LOAD} = 600pF$, SPD = 0, f = 750KHz, (Note 5)			75	
I_{BUS}	V_{BUS} Supply current	D+, D- are idle, $V_{BUS} = 5.25V$ Suspend Mode (SUS = 1), OE# = 1, SPD = 1			200	μA
		D+, D- are idle, $V_{BUS} = 5.25V$ SPD = 1, OE# = SUS = 0			5	mA
		D+, D- are idle, $V_{BUS} = 5.25V$ OE# = SUS = SPD = 0			700	μA
		D+, D- are idle, $V_{BUS} = 5.25V$ OE# = 1, SUS = SPD = 0			350	
		D+, D- active, $V_{BUS} = 5.25V$ $C_{LOAD} = 50pF$, SPD = 1, f = 6 MHz OE# = SUS = 0 (Note 5)			10	mA
		D+, D- active, $V_{BUS} = 5.25V$ $C_{LOAD} = 600pF$, f = 750 KHz, OE# = SUS = SPD = 0 (Note 5)			5	
$I_{VPULLEAK}$	V_{PU} Leakage current	CON = 0, $V_{PU} = 0V$	-5		5	μA
$I_{VIFLEAK}$	V_{IF} Leakage current	$V_{IF} = 3.6V$, $V_{BUS} = 0V$	-5		5	μA
V_{PU}	Pull-Up output voltage	$I_{TERM} = 200\mu A$, $V_{BUS} = 4$ to $5.25V$	3		3.6	V
R_{SW}	V_{PU} Internal switch resistance	$I_{TERM} = 10mA$, $V_{BUS} = 4$ to $5.25V$	7	9	11	Ω

Note 1. Exceeding the absolute maximum rating may damage the device.

Note 2. The device is not guaranteed to function outside its operating rating.

Note 3. Devices are ESD sensitive. Handling precautions recommended. Human body model, 1.5k Ω in series with 100pF.

Note 4. Specification applies to the following pins: SUS, SPD, RCV, CON, VP, VM, OE#, VBUSDDET.

Note 5. Characterized specification(s), but not production tested.

Note 6. All AC parameters guaranteed by design but not production tested.

Note 7. RCV NOT LOADED

Table 7. DC electrical characteristics (System and USB interface)
($V_{IF} = 3.6V$, $V_{BUS} = 5V$ unless otherwise noted; $T_A = 25^\circ C$)

Symbol	Parameter	Test Conditions	Min.	Typ.	Max.	Unit
V_{BUS}	USB Supply voltage		4		5.5	V
V_{IF}	System I/F supply voltage		1.6		3.6	V
V_{IL}	Low level input voltage (Note 4)				$0.15V_{IF}$	V
V_{IH}	High level input voltage (Note 4)		$0.85V_{IF}$			V
V_{OL}	Low level output voltage (Note 4)	$I_{OL} = 20\mu A$			0.1	V
V_{OH}	High level output voltage (Note 4)	$I_{OH} = 20\mu A$	$0.9V_{IF}$			V
I_{IL}	Input leakage current (Note 4)		-5		5	μA
I_{IF}	V_{IF} Supply current (Note 7)	D+, D- are idle, OE# = SUS = 0			5	μA
		D+, D- active, $C_{LOAD} = 50pF$, SPD = 1, f = 6MHz, (Note 5)		450		
		D+, D- active, $C_{LOAD} = 50pF$, SPD = 0, f = 750KHz, (Note 5)		50		
I_{BUS}	V_{BUS} Supply current	D+, D- are idle, $V_{BUS} = 5.25V$ Suspend Mode (SUS = 1)		70	150	μA
		D+, D- are idle, $V_{BUS} = 5.25V$ SPD = 1, OE# = SUS = 0		3.0		mA
		D+, D- are idle, $V_{BUS} = 5.25V$ OE# = SUS = SPD = 0		300		μA
		D+, D- are idle, $V_{BUS} = 5.25V$ OE# = 1, SUS = SPD = 0		150		μA
		D+, D- active, $V_{BUS} = 5.25V$ $C_{LOAD} = 50pF$, SPD = 1, f = 6 MHz OE# = SUS = 0 (Note 5)		7.3		mA
		D+, D- active, $V_{BUS} = 5.25V$ $C_{LOAD} = 600pF$, f = 750 KHz, OE# = SUS = SPD = 0 (Note 5)		3.6		mA
$I_{VPULEAK}$	V_{PU} Leakage current	CON = 1, $V_{PU} = 0V$	-5		5	μA
$I_{VIFLEAK}$	V_{IF} Leakage current	$V_{IF} = 3.6V$, $V_{BUS} = 0V$	-5		5	μA
V_{PU}	Pull-Up output voltage	$I_{TERM} = 200\mu A$, $V_{BUS} = 4$ to $5.25V$		3.3		V
R_{SW}	V_{PU} Internal switch resistance	$I_{TERM} = 10mA$, $V_{BUS} = 4$ to $5.25V$		9		Ω

Note 1. Exceeding the absolute maximum rating may damage the device.

Note 2. The device is not guaranteed to function outside its operating rating.

Note 3. Devices are ESD sensitive. Handling precautions recommended. Human body model, $1.5k\Omega$ in series with $100pF$.

Note 4. Specification applies to the following pins: SUS, SPD, RCV, CON, VP, VM, OE#, VBUSDET.

Note 5. Characterized specification(s), but not production tested.

Note 6. All AC parameters guaranteed by design but not production tested.

Note 7. RCV NOT LOADED

Table 8. ESD Performance

Symbol	Parameter	Test Conditions	Min.	Typ.	Max.	Unit
ESD	IEC-1000-4-2 (D+, D-)	Air discharge (10 pulses)		± 8		kV
		Contact discharge (10 pulses)		± 6		
	IEC-1000-4-2 (V_{BUS} only)	Air discharge (10 pulses)		± 5		
		Contact discharge (10 pulses)		± 5		

Table 9. DC electrical characteristics (Transceiver)

($V_{IF} = 3.6V$, $V_{BUS} = 5V$ unless otherwise noted; $T_A = 25^\circ C$, specifications over temperature, -40 to $85^\circ C$)

Symbol	Parameter	Test Conditions	Min.	Typ.	Max.	Unit
I_{LO}	Hi-Z State data line leakage (suspend mode)	$V_I = 0$ to 3.3 V, SUS = 1	-10		10	μA
V_{DI}	Differential input sensitivity	$ I(D+) - (D-) $	0.2			V
V_{CM}	Differential common mode range	Includes V_{DI} range	0.8		2.5	V
V_{SE}	Single ended receiver threshold		0.8		2.0	V
V_{RHYS}	Receiver hysteresis	$V_{CM} = 0.8$ V		100		mV
V_{OL}	Static output low	$R_L = 1.5$ K Ω at 3.6V (see test circuit)			0.3	V
V_{OH}	Static output high	$R_L = 15$ K Ω at GND (see test circuit)	2.8		3.6	V
C_I	Transceiver capacitance	Pin to GND		25		pF
Z_{DRV}	Driver output resistance	Steady state drive	9		22	Ω

Table 10. DC electrical characteristics (Transceiver)

($V_{IF} = 3.6V$, $V_{BUS} = 5V$ unless otherwise noted; $T_A = 25^\circ C$)

Symbol	Parameter	Test Conditions	Min.	Typ.	Max.	Unit
I_{LO}	Hi-Z state data line leakage (suspend mode)	$V_I = 0$ to 3.3 V, SUS = 1	-2		2	μA
V_{DI}	Differential input sensitivity	$ I(D+) - (D-) $	0.2			V
V_{CM}	Differential common mode range	Includes V_{DI} range	0.8		2.5	V
V_{SE}	Single ended receiver threshold		0.8		2	V
V_{RHYS}	Receiver hysteresis	$V_{CM} = 0.8$ V		50		mV
V_{OL}	Static output low	$R_L = 1.5$ K Ω at 3.6V (see Test circuits)			0.3	V
V_{OH}	Static output high	$R_L = 15$ K Ω at GND (see Test circuits)	2.8		3.6	V
C_I	Transceiver Capacitance ⁽³⁾	Pin to GND		25		pF
Z_{DRV}	Driver Output Resistance	Steady state drive		16		Ω

(3) Pins D+, D-

Table 11. AC electrical characteristics(V_{IF} = 3.6V, V_{BUS} = 5V unless otherwise noted; T_A = 25°C.) (Note 6)

Symbol	Parameter	Test Conditions	Min.	Typ.	Max.	Unit
T _R	Transition Rise Time (LOW SPEED)	C _L = 50pF (<i>Figure 4</i>)	75			ns
		C _L = 600pF			300	
T _F	Transition Fall Time (LOW SPEED)	C _L = 50pF (<i>Figure 4</i>)	75			ns
		C _L = 600pF			300	
T _R , T _F	Rise/Fall Time Matching (LOW SPEED)	(T _R , T _F)	80		125	%
V _{CRS}	Output Signal Crossover Voltage (LOW SPEED)		1.3		2	V
T _R	Transition Rise Time (FULL SPEED)	C _L = 50pF (<i>Figure 4</i>)	4		20	ns
T _F	Transition Fall Time (FULL SPEED)	C _L = 50pF (<i>Figure 4</i>)	4		20	ns
T _R , T _F	Rise/Fall Time Matching (FULL SPEED)	(T _R , T _F)	90		111.11	%
V _{CRS}	Output Signal Crossover Voltage (FULL SPEED)		1.3		2	V
t _{PVZ}	OE# TO RCVR Tri-State Delay	<i>Figure 3</i>		3		ns
t _{PZD}	Receiver Tri-State to Transmit Delay	LOW SPEED (<i>Figure 3</i>)	13			ns
		FULL SPEED (<i>Figure 3</i>)	32			
t _{PDZ}	OE# TO RCVR Tri-State Delay	<i>Figure 3</i>		6		ns
t _{PZV}	Driver Tri-State to Receive Delay	<i>Figure 3</i>		27		ns
t _{PLH} t _{PHL}	VP, VM to D+, D- Propagation Delay	<i>Figure 6</i>		16	20	ns
t _{PLH} t _{PHL}	D+, D- to RCV Propagation Delay	<i>Figure 5</i>		13	20	ns
t _{PLH} t _{PHL}	D+, D- to VP, VM Propagation Delay	<i>Figure 5</i>		8	20	ns

Note 1. Exceeding the absolute maximum rating may damage the device.

Note 2. The device is not guaranteed to function outside its operating rating.

Note 3. Devices are ESD sensitive. Handling precautions recommended. Human body model, 1.5kΩ in series with 100pF.

Note 4. Specification applies to the following pins: SUS, SPD, RCV, CON, RCV, VP, VM, OE#.

Note 5. Characterized specification(s), but not production tested.

Note 6. All AC parameters guaranteed by design but not production tested.

6 Timing diagram

Figure 3. Enable and disable times

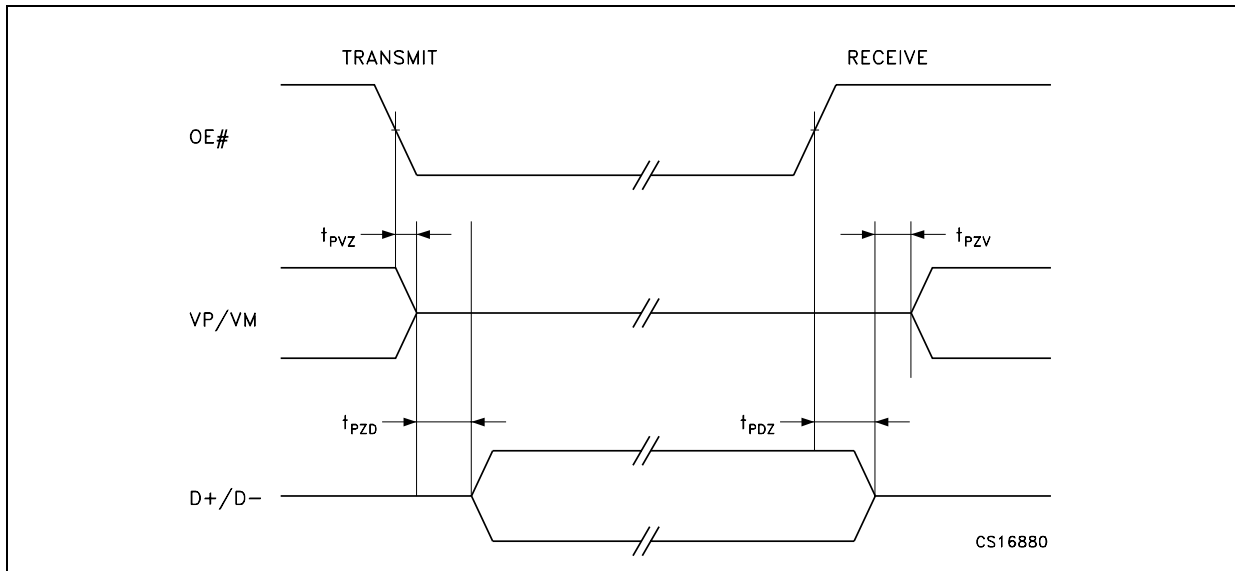

Figure 4. Rise and fall times

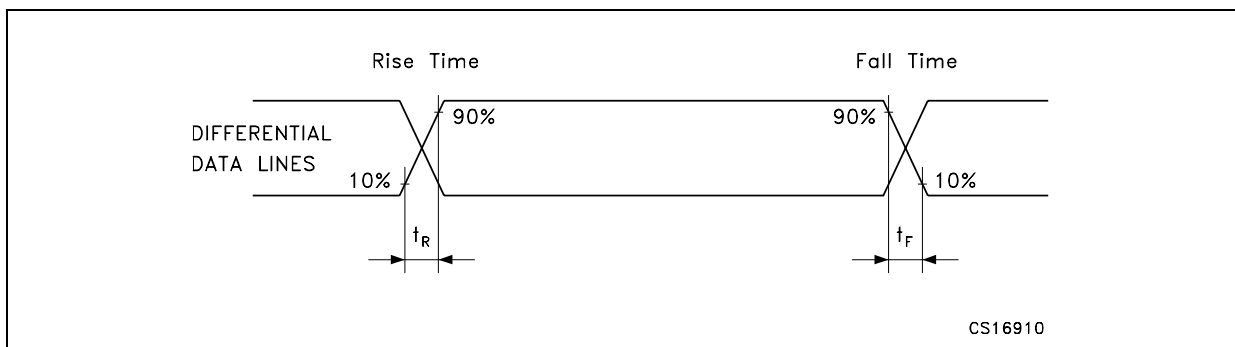

Figure 5. Receiver propagation delay

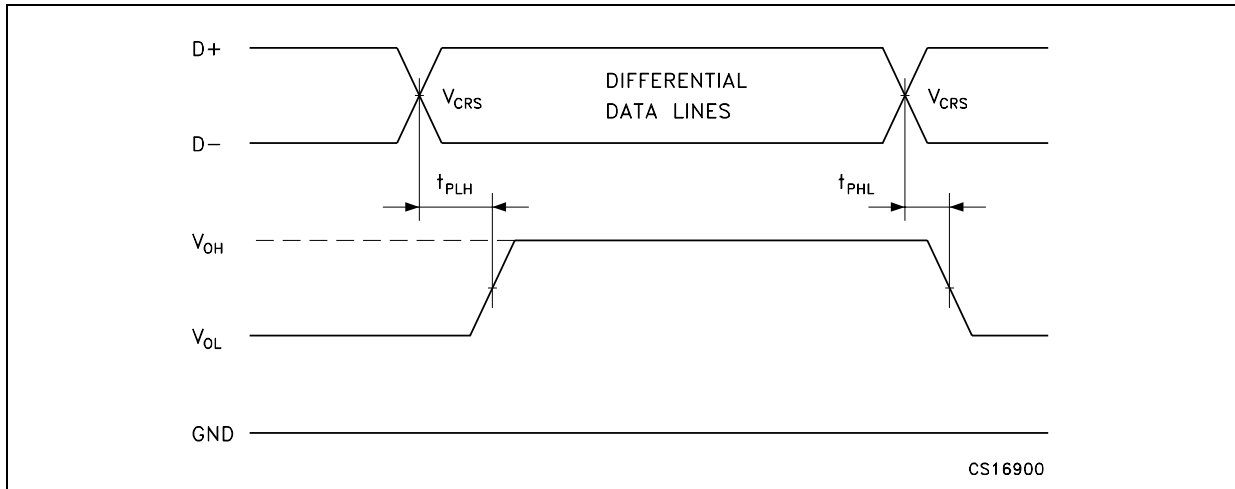
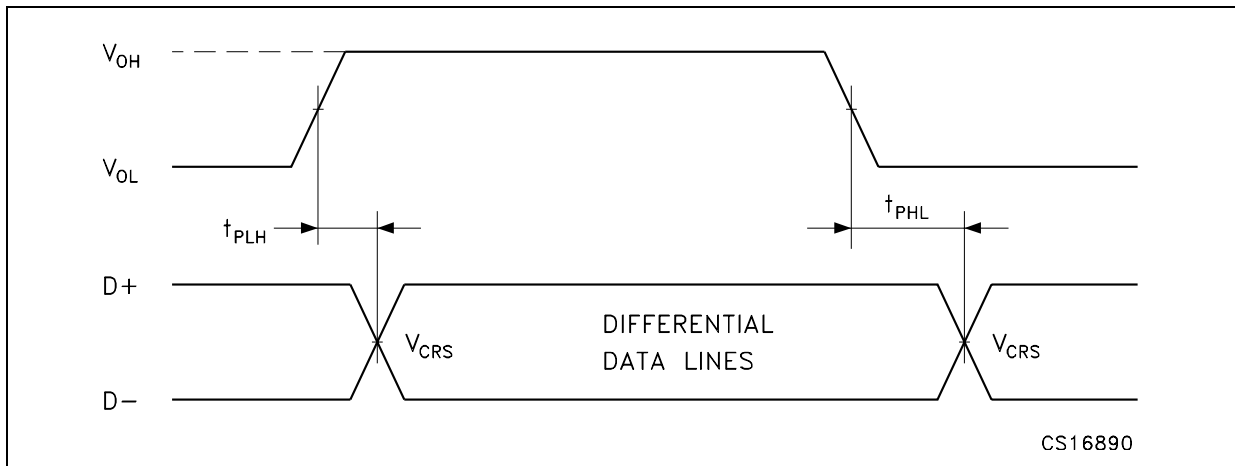
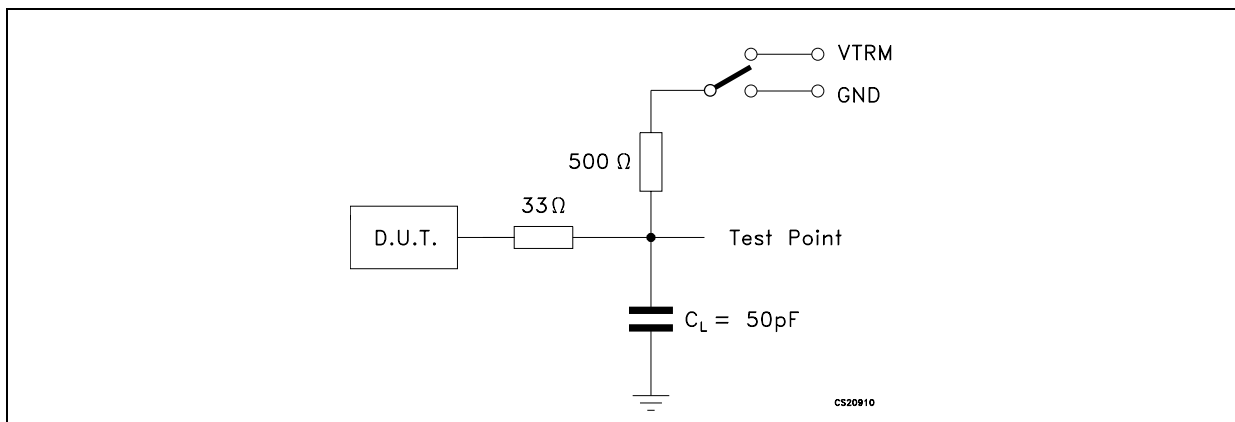

Figure 6. Driver propagation delay (C_L = 50pF)



Minimum Timing LS and maximum timing FS

Figure 7. Enable and disable time circuit



Switch = GND for t_{pZH} and t_{pHZ}; V = VTRM for t_{pZL} and t_{pLZ}

7 Test circuits

Figure 8. Load for VP, VM, RCV

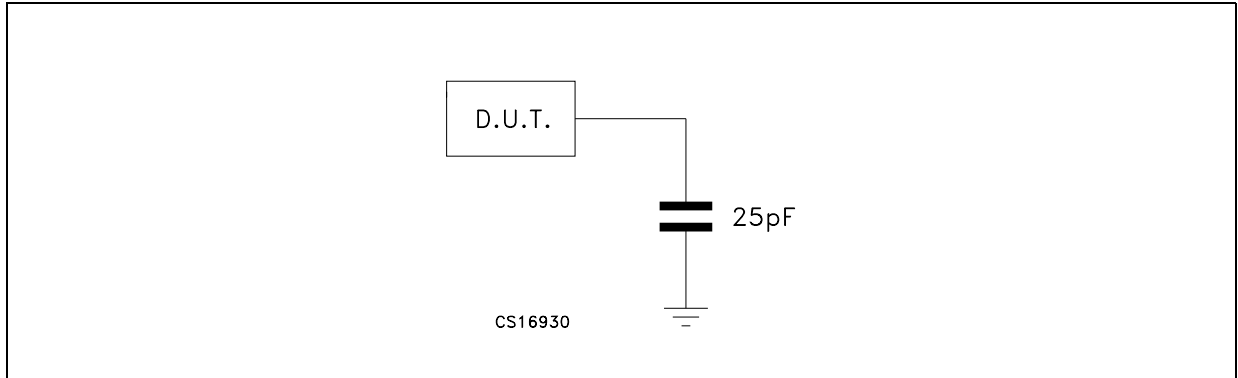

Figure 9. Load for D+, D-

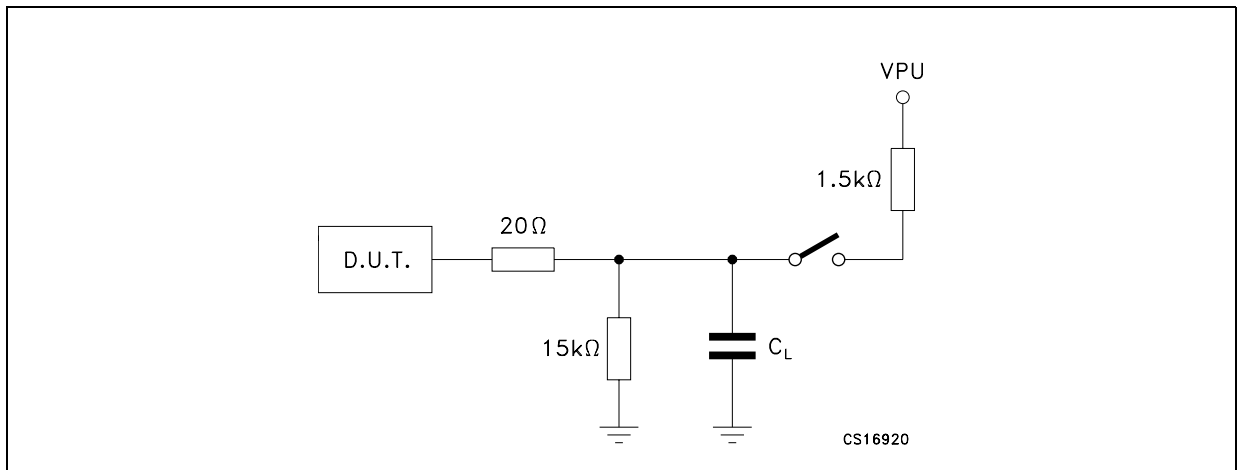
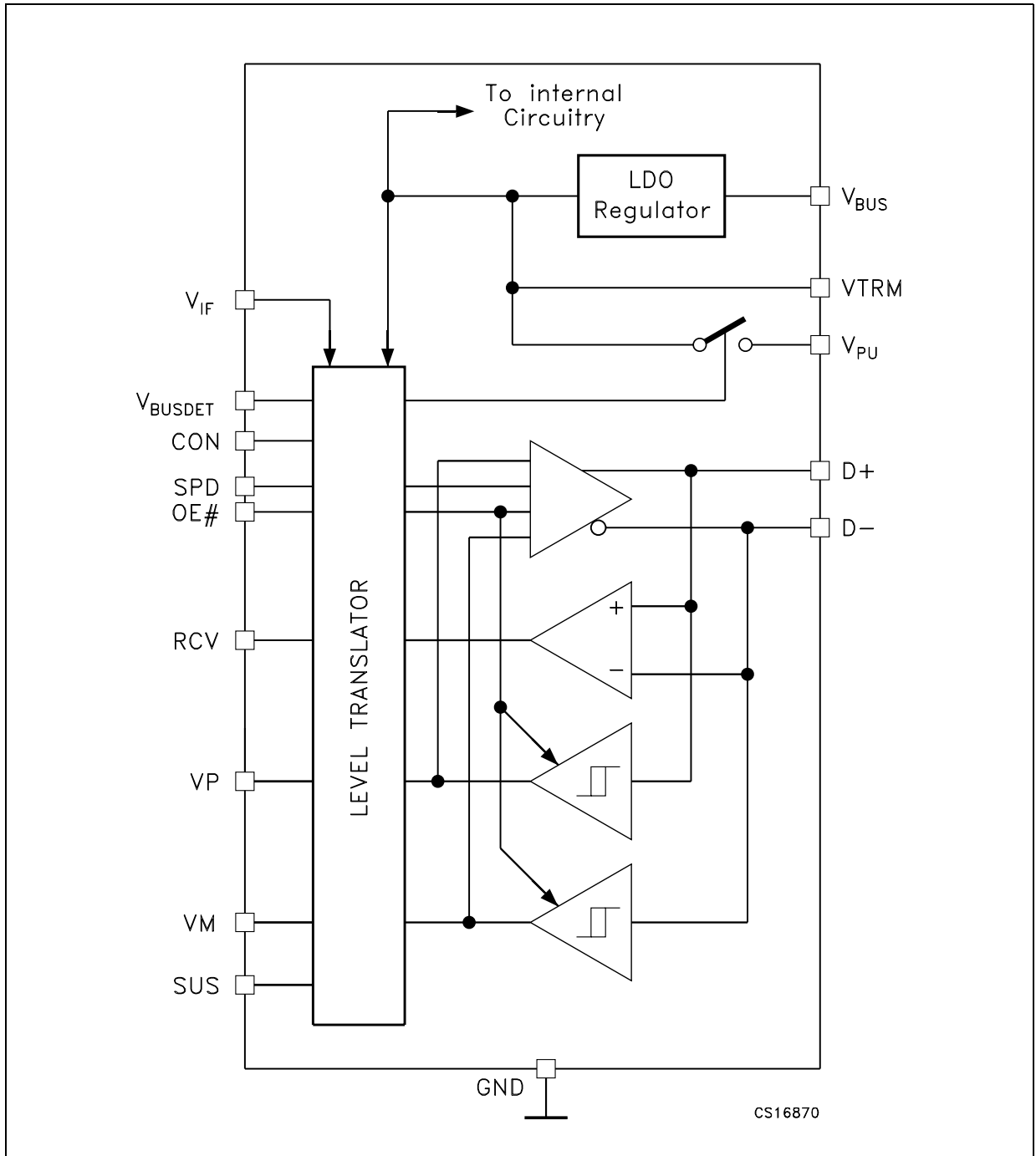

Figure 10. Functional diagram



8 Functional description

The STUSB02E is designed to provide USB connectivity in mobile systems where available system supply voltages are not able to satisfy USB requirements. The STUSB02E can operate down to supply voltages of 1.6V. As shown in the circuit above, the STUSB02E takes advantage of the USB supply voltage, V_{BUS} , to operate the transceiver. The system voltage, V_{IF} is used to set the reference voltage used by the digital I/O lines interfacing to the system controller. Internal circuitry provides translation between the USB and system voltage domains. V_{IF} will typically be the main supply voltage rail for the controller.

In addition, a 3.3V, 10% termination supply voltage, V_{PU} , is provided to support speed selection. V_{PU} can be disabled or enabled under software control via the CON input. This allows for software-controlled connect or disconnect states. A 1.5K Ω resistor is required to be connected between this pin and the D+ or D- lines to respectively specify full speed or low speed operation.

The use of ESD transient protection devices is not required for operation, but is recommended.

9 Package mechanical data

In order to meet environmental requirements, ST offers these devices in ECOPACK® packages. These packages have a Lead-free second level interconnect. The category of second Level Interconnect is marked on the package and on the inner box label, in compliance with JEDEC Standard JESD97. The maximum ratings related to soldering conditions are also marked on the inner box label. ECOPACK is an ST trademark. ECOPACK specifications are available at: www.st.com.

QFN16 (3mmx3mm) MECHANICAL DATA

DIM.	mm.			inch		
	MIN.	TYP	MAX.	MIN.	TYP.	MAX.
A	0.80	0.90	1.00	0.032	0.035	0.039
A1		0.02	0.05		0.001	0.002
A3		0.20			0.008	
b	0.18	0.25	0.30	0.007	0.010	0.012
D		3.00			0.118	
D2	1.55	1.70	1.80	0.061	0.067	0.071
E		3.00			0.118	
E2	1.55	1.70	1.80	0.061	0.067	0.071
e		0.50			0.020	
K		0.20			0.008	
L	0.30	0.40	0.50	0.012	0.016	0.020
r	0.09			0.006		

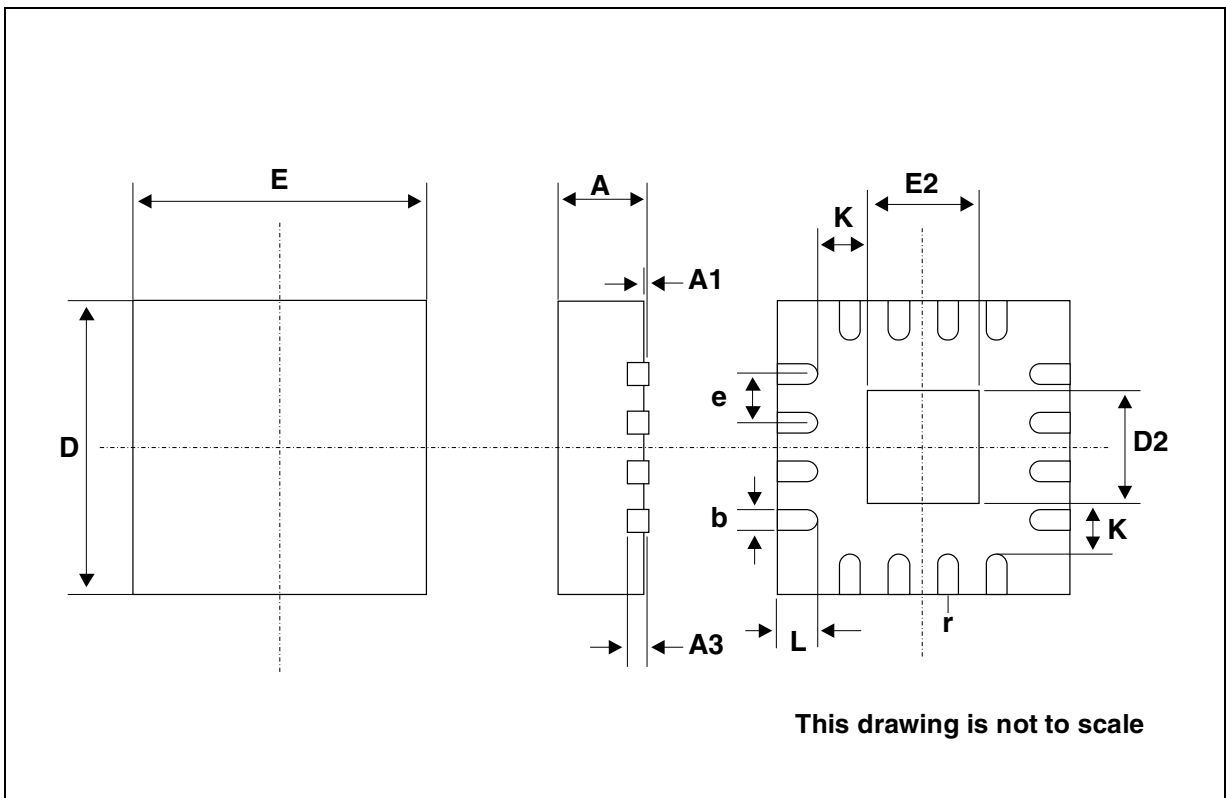

Tape & Reel QFNxx/DFNxx (3x3) MECHANICAL DATA

DIM.	mm.			inch		
	MIN.	TYP	MAX.	MIN.	TYP.	MAX.
A			330			12.992
C	12.8		13.2	0.504		0.519
D	20.2			0.795		
N	60			2.362		
T			18.4			0.724
Ao		3.3			0.130	
Bo		3.3			0.130	
Ko		1.1			0.043	
Po		4			0.157	
P		8			0.315	

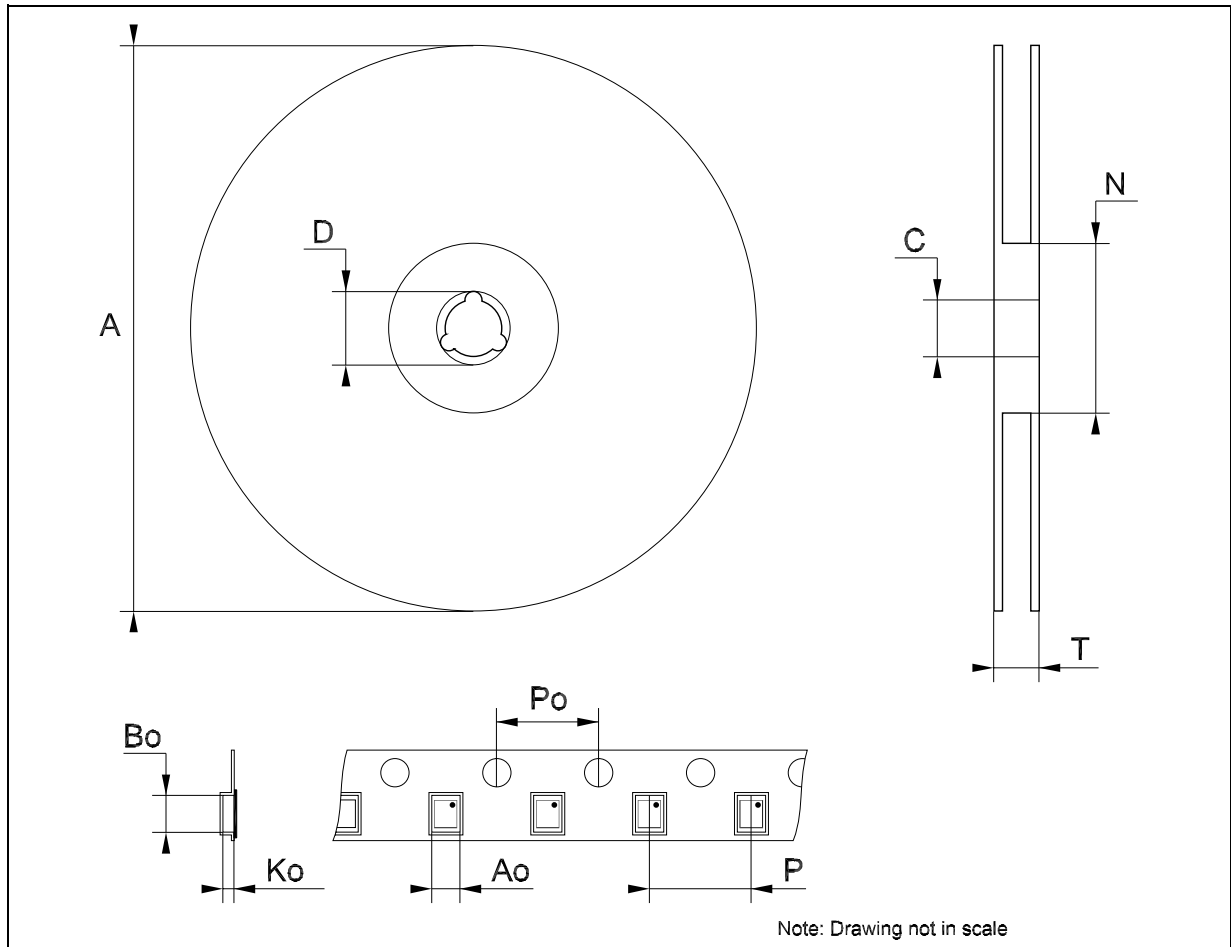

10 Revision history

Table 12. Revision history

Date	Revision	Changes
19-Oct-2005	1	First Release.
21-Feb-2006	2	Declaration of conformity with USB 2.0 specification removed.
07-Apr-2006	3	Corrected wrong links to figures in table 11.
14-Mar-2007	4	Update tape & reel.

Please Read Carefully:

Information in this document is provided solely in connection with ST products. STMicroelectronics NV and its subsidiaries ("ST") reserve the right to make changes, corrections, modifications or improvements, to this document, and the products and services described herein at any time, without notice.

All ST products are sold pursuant to ST's terms and conditions of sale.

Purchasers are solely responsible for the choice, selection and use of the ST products and services described herein, and ST assumes no liability whatsoever relating to the choice, selection or use of the ST products and services described herein.

No license, express or implied, by estoppel or otherwise, to any intellectual property rights is granted under this document. If any part of this document refers to any third party products or services it shall not be deemed a license grant by ST for the use of such third party products or services, or any intellectual property contained therein or considered as a warranty covering the use in any manner whatsoever of such third party products or services or any intellectual property contained therein.

UNLESS OTHERWISE SET FORTH IN ST'S TERMS AND CONDITIONS OF SALE ST DISCLAIMS ANY EXPRESS OR IMPLIED WARRANTY WITH RESPECT TO THE USE AND/OR SALE OF ST PRODUCTS INCLUDING WITHOUT LIMITATION IMPLIED WARRANTIES OF MERCHANTABILITY, FITNESS FOR A PARTICULAR PURPOSE (AND THEIR EQUIVALENTS UNDER THE LAWS OF ANY JURISDICTION), OR INFRINGEMENT OF ANY PATENT, COPYRIGHT OR OTHER INTELLECTUAL PROPERTY RIGHT.

UNLESS EXPRESSLY APPROVED IN WRITING BY AN AUTHORIZED ST REPRESENTATIVE, ST PRODUCTS ARE NOT RECOMMENDED, AUTHORIZED OR WARRANTED FOR USE IN MILITARY, AIR CRAFT, SPACE, LIFE SAVING, OR LIFE SUSTAINING APPLICATIONS, NOR IN PRODUCTS OR SYSTEMS WHERE FAILURE OR MALFUNCTION MAY RESULT IN PERSONAL INJURY, DEATH, OR SEVERE PROPERTY OR ENVIRONMENTAL DAMAGE. ST PRODUCTS WHICH ARE NOT SPECIFIED AS "AUTOMOTIVE GRADE" MAY ONLY BE USED IN AUTOMOTIVE APPLICATIONS AT USER'S OWN RISK.

Resale of ST products with provisions different from the statements and/or technical features set forth in this document shall immediately void any warranty granted by ST for the ST product or service described herein and shall not create or extend in any manner whatsoever, any liability of ST.

ST and the ST logo are trademarks or registered trademarks of ST in various countries.

Information in this document supersedes and replaces all information previously supplied.

The ST logo is a registered trademark of STMicroelectronics. All other names are the property of their respective owners.

© 2007 STMicroelectronics - All rights reserved

STMicroelectronics group of companies

Australia - Belgium - Brazil - Canada - China - Czech Republic - Finland - France - Germany - Hong Kong - India - Israel - Italy - Japan - Malaysia - Malta - Morocco - Singapore - Spain - Sweden - Switzerland - United Kingdom - United States of America

www.st.com