

1. MAXIMUM PANEL THICKNESS = 6.35 [.25]
2. USE HAND TOOL 220022-2
3. USE INSTRUCTION SHEET 9821

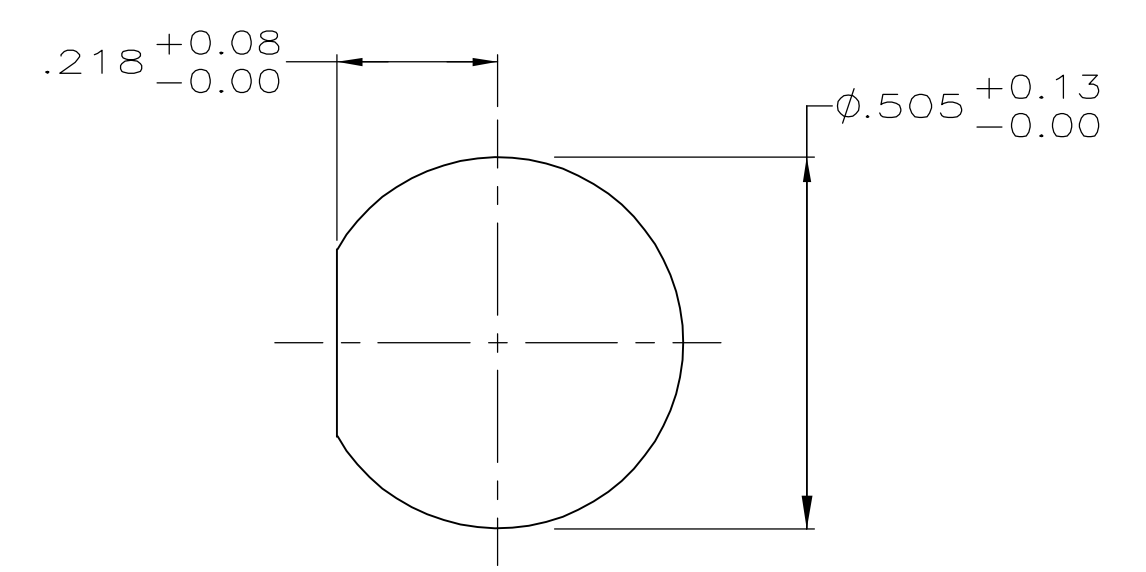

RECOMMENDED PANED CUTOUT
SCALE 4:1

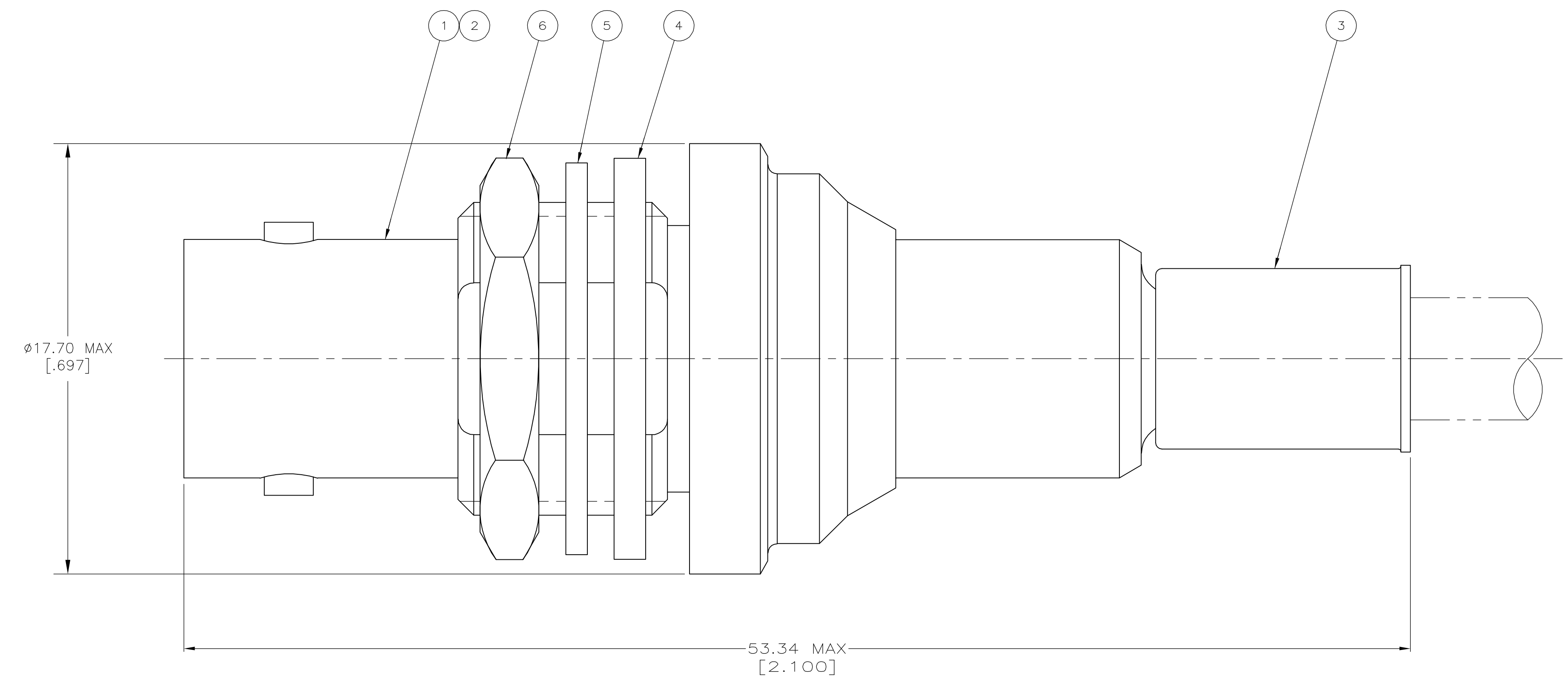
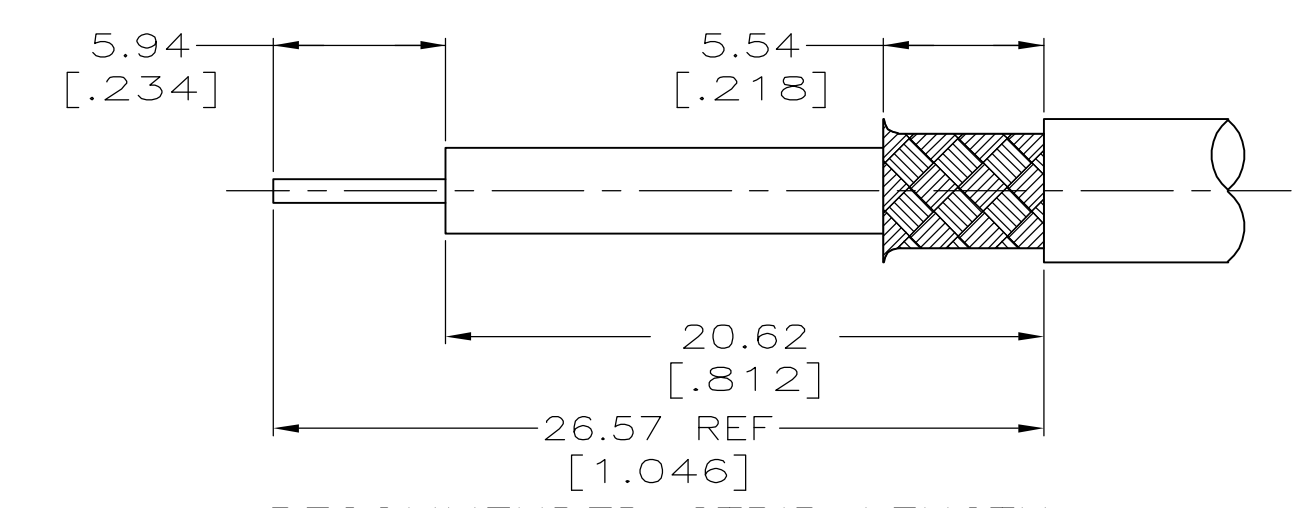

RECOMMENDED STRIP LENGTH
SCALE 4:1

OBSOLETE	RG-71/U	1-329631-2	1-329632-2	329633	1-329460-1	225057-2	225060-4	225059-4
	RG-59/U, 59A/U, 59B/U, 62/U, 62A/U, 62B/U	1-329631-2	1-329632-2	328633	9-50428-0	225057-2	225060-4	225059-3
OBSOLETE	RG-71/U	329631	329632	329633	329460	225057-2	225060-2	225059-2
SUPERSEDED BY	225059-3	-	-	-	-	-	-	225059-1
	FOR USE WITH CABLE	⑥ JAM NUT QTY=1	⑤ LOCK WASHER QTY=1	④ GASKET QTY=1	③ FERRULE QTY=1	② CONTACT QTY=1	① JACK ASSEMBLY QTY=1	PART NUMBER

THIS DRAWING IS A CONTROLLED DOCUMENT.

DIMENSIONS:	TOLERANCES UNLESS OTHERWISE SPECIFIED:	DWN	M.E. COWHER	3-2-93	Tyco Electronics Corporation Harrisburg, Pa 17105-3608
mm(INCHES)	0 PLC ± - 1 PLC ± - 2 PLC ± 041 [018] 3 PLC ± - 4 PLC ± - ANGLES ± -	CHK	M.L. PHILLIPS	3-3-93	
MATERIAL	FINISH	APVD	-	NAME	JACK, BULKHEAD, SHV
		PRODUCT SPEC	-	APPLICATION SPEC	-
		WEIGHT	-	SIZE	A1
		CUSTOMER DRAWING		SCALE	4:1

SIZE: A1 00779 C=225059 SHEET 1 OF 1 REV G