

THIS IS A C.A.D. GENERATED DRAWING
DO NOT MAKE MANUAL REVISIONS TO MASTER.



ISSUE NUMBER

ORIGINAL

①

TO OPEN PARTIALLY CLOSED TOOL
PUSH THIS LATCH IN THE DIRECTION
OF THE ARROW.

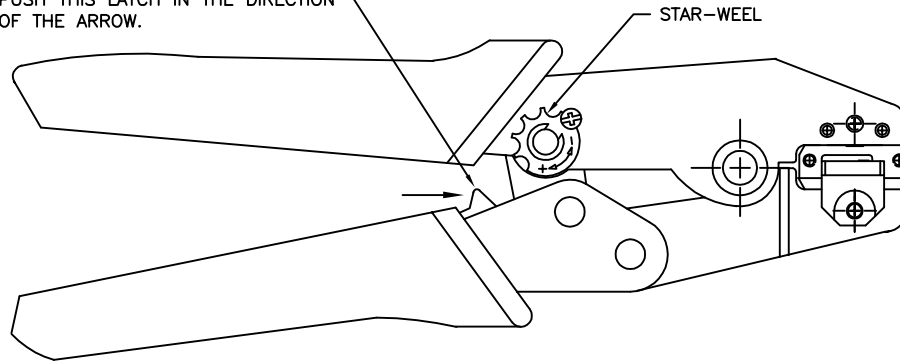

STAR-WHEEL

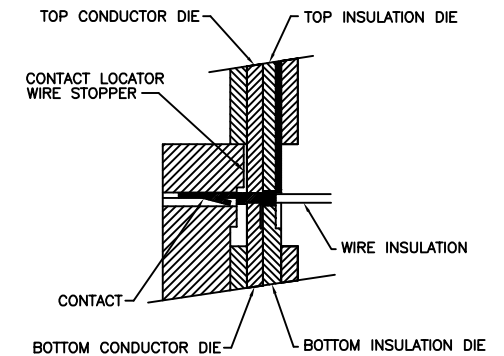

SECTION THROUGH DIE NEST
WITH CONTACT IN POSITION

NOTES:

WIRE AWG	CRIMP STRENGTH
20 AWG	15.4 LBS
22 AWG	11.0 LBS
24 AWG	6.6 LBS
26 AWG	4.4 LBS
28 AWG	2.2 LBS

- 1- THIS HAND TOOL IS DESIGNED FOR CRIMPING 20 TO 28 AWG WIRES TO EDAC CONTACT P/N 565-290-711/721/731/741.
- 2- RISK OF ELECTRIC SHOCK- DO NOT USE THIS ON LIVE WIRE.
- 3- CRIMPING INSTRUCTIONS:
 - OPEN THE TOOL, PLACE THE CONTACT INTO THE CORRECT DIE NEST.
 - PARTIALLY CLOSE THE TOOL UNTIL THE CONTACT IS HELD IN PLACE. INSERT THE WIRE INTO THE CONTACT.
 - CLOSE THE TOOL UNTIL THE RATCHET RELEASES. REMOVE THE CRIMPED CONTACT.
- 4- ADJUSTMENT OF CRIMP FORCE (WHEN NECESSARY):
 - LOOSEN THE SCREW
 - ADJUST THE STAR-WHEEL BY TURNING FROM (-) TO(+).
 - CHECK THE PRELOAD AND THE CRIMP FORCE.

TOOL PART NUMBER: 565-280-201

565 SERIES HAND CRIMP TOOL INSTRUCTIONS		ACAD REFERENCE NO. 565-280-201	
		DRAWN: K.L.	DATE: AUG.6/2020
 EDAC INC TORONTO, ONTARIO CANADA YOUR CONNECTION TO QUALITY & SERVICE		CHECKED: R.S.M.	DATE: AUG.6/2020
		SCALE: N.T.S.	SHEET 1 OF 2
THESE DRAWINGS AND SPECIFICATIONS ARE THE PROPERTY OF EDAC INC., AND SHALL NOT BE REPRODUCED, OR COPIED OR USED AS THE BASIS FOR THE MANUFACTURE OR SALE OF APPARATUS WITHOUT WRITTEN PERMISSION.		DRAWING NUMBER	
		565-280-201	
		ISSUE	
		1	

THIS IS A C.A.D. GENERATED DRAWING
DO NOT MAKE MANUAL REVISIONS TO MASTER.



ISSUE NUMBER

ORIGINAL

①

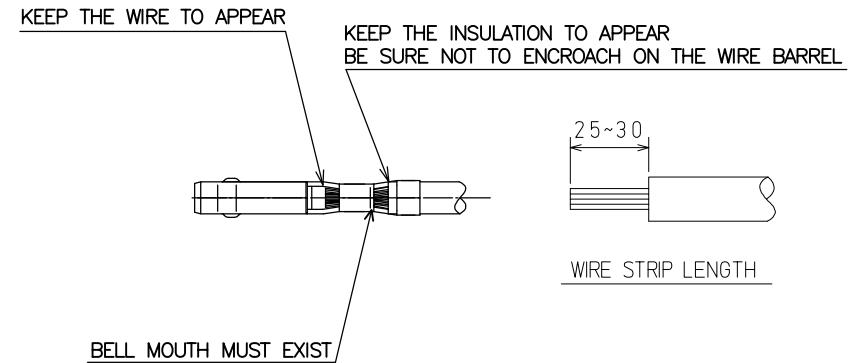
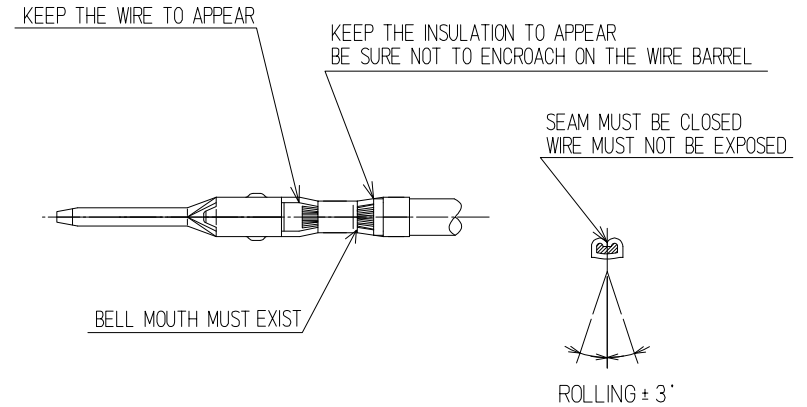
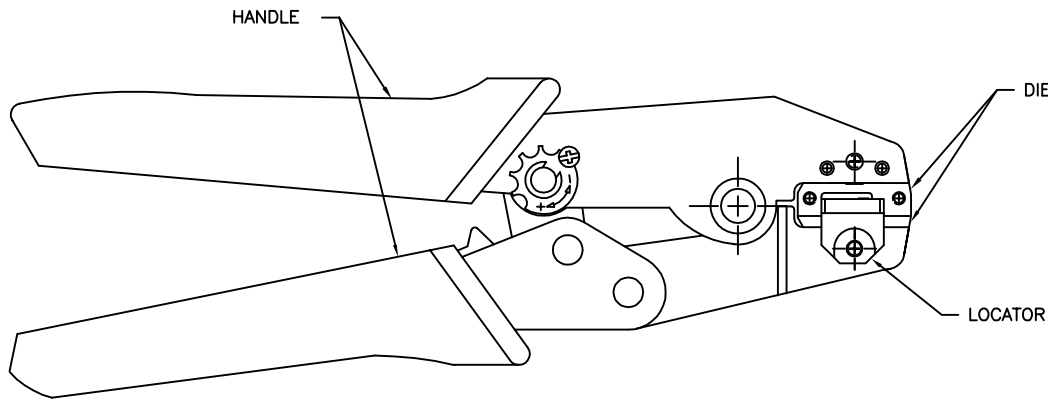

CRIMP ASM*	HAND TOOL	LOCATOR KIT SET
565-280-201	565-281-201	565-282-001

* Assembly includes: Handle, Die and Locator. Parts are available for purchase separately.

565 SERIES HAND CRIMP TOOL INSTRUCTIONS

EDAC EDAC INC
TORONTO, ONTARIO
CANADA
YOUR CONNECTION TO QUALITY & SERVICE

THESE DRAWINGS AND SPECIFICATIONS ARE THE PROPERTY OF EDAC INC., AND SHALL NOT BE REPRODUCED, OR COPIED OR USED AS THE BASIS FOR THE MANUFACTURE OR SALE OF APPARATUS WITHOUT WRITTEN PERMISSION.

ACAD REFERENCE NO. 565-280-201

DRAWN: K.L.

DATE: AUG.6/2020

CHECKED: R.S.M.

DATE: AUG.6/2020

SCALE: N.T.S.

SHEET 2 OF 2

DRAWING NUMBER

565-280-201

ISSUE

1