

SMA6HS5.0A-Q1 THRU SMA6HS85A-Q1

List

List..... 1

Package outline..... 2

Features..... 2

Mechanical data..... 2

Maximum ratings 2

Electrical characteristics..... 3

Rating and characteristic curves..... 4~5

Pinning information..... 6

Marking..... 6

Suggested solder pad layout..... 6

Packing information..... 7

Reel packing..... 8

Suggested thermal profiles for soldering processes..... 8

High reliability test capabilities..... 9

SMA6HS5.0A-Q1 THRU SMA6HS85A-Q1

600W Surface Mount Unidirectional Transient Voltage Suppressors Diodes 5.0V-85V

Features

- Uni-directional
- Very low profile - typical height of 1.0 mm
- 600W peak pulse power capability with a 10/1000µs waveform, repetition rate (duty cycle): 0.01%
- Low profile surface mounted application in order to optimize board space
- Excellent clamping capability
- Low incremental surge resistance
- Glass passivated chip junction
- Lead-free parts meet RoHS requirements
- Qualified to AEC-Q101 standards for high reliability
- Suffix "-H" indicates Halogen free parts, ex. SMA6HS5.0A-Q1-H

Mechanical data

- Epoxy:UL94-V0 rated flame retardant
- Case : Molded plastic,DO-221AC / SMA-HS
- Terminals : Solder plated, solderable per MIL-STD-750, Method 2026
- Polarity : Indicated by cathode band
- Mounting Position : Any
- Weight : Approximated 0.037 gram

Package outline

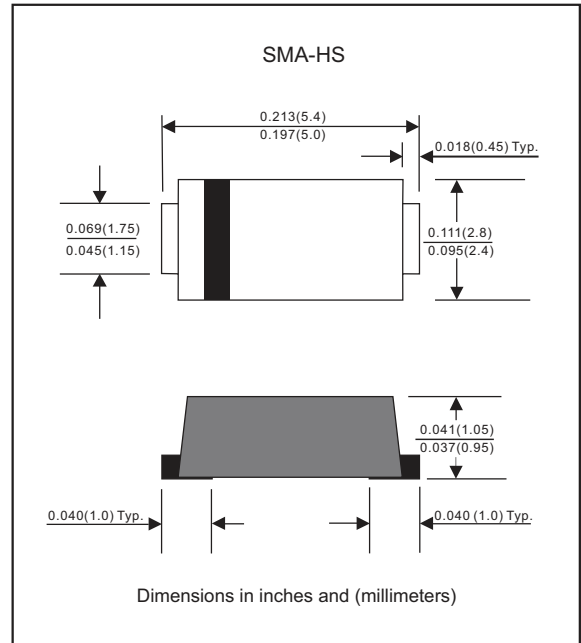

Maximum ratings (AT $T_A=25^\circ\text{C}$ unless otherwise noted)

| Parameter | Conditions | Symbol | Value | Unit |
|---------------------------------------|---|------------------------------------|-------------|--------------------|
| Peak power dissipation | with a 10/1000µs waveform, Note 1, 2 & Fig. 1 | PPPM | 600 | W |
| Peak pulse current | with a 10/1000µs waveform | IPPM | See Table 1 | A |
| Steady state power dissipation | at $T_L=75^\circ\text{C}$, Note 2 | PM(AV) | 4.5 | W |
| Peak forward surge current | 8.3ms single half sine-wave, Note 3 | IFSM | 60 | A |
| Maximum instantaneous forward voltage | at $I_F=25\text{A}$ For uni-directional types only, Note 4 | V_F | 3.5 | V |
| Typical thermal resistance | Junction to case Junction to ambient | $R_{\theta JC}$ $R_{\theta JA}$ | 32 52 | $^\circ\text{C/W}$ |
| Operating junction temperature range | | T_J | -55 to +150 | $^\circ\text{C}$ |
| Storage temperature range | | T_{STG} | -65 to +175 | $^\circ\text{C}$ |

Notes 1. Non-repetitive current pulse, per Fig. 3 and derated above $T_A=25^\circ\text{C}$ per Fig. 2
 2. Mounted on copper pad area of 0.2"x0.2" (5.0x5.0 mm) per Fig 5
 3. Measured on 8.3 ms single half sine-wave or equivalent square wave, duty cycle=4 pulses per minute maximum
 4. $V_r < 3.5\text{V}$ for $V_{BR} < 200\text{V}$

Electrical characteristics (at $T_A=25^{\circ}\text{C}$ unless otherwise noted)

| Part No. (Uni) | Reverse Stand-off Voltage | | Breakdown Voltage @ I_T | | Test Current | Maximum Clamping Voltage @ I_{PP} | | Maximum Reverse Leakage Current | Marking Code Uni |
|-------------------|---------------------------|--------------------|---------------------------|-------|--------------|-------------------------------------|---------------|---------------------------------|-------------------------|
| | V_{RWM} | $V_{BR\text{Min}}$ | $V_{BR\text{Max}}$ | I_T | V_c | I_{PP} | $I_R@V_{RWM}$ | | |
| | Volts | Volts | Volts | mA | Volts | A | μA | | |
| SMA6HS5.0A-Q1 | 5.0 | 6.40 | 7.00 | 10 | 9.2 | 65.2 | 800 | 6AE | |
| SMA6HS6.0A-Q1 | 6.0 | 6.67 | 7.37 | 10 | 10.3 | 58.3 | 800 | 6AG | |
| SMA6HS6.5A-Q1 | 6.5 | 7.22 | 7.98 | 10 | 11.2 | 53.6 | 500 | 6AK | |
| SMA6HS7.0A-Q1 | 7.0 | 7.78 | 8.60 | 10 | 12.0 | 50.0 | 200 | 6AM | |
| SMA6HS7.5A-Q1 | 7.5 | 8.33 | 9.21 | 1.0 | 12.9 | 46.5 | 100 | 6AP | |
| SMA6HS8.0A-Q1 | 8.0 | 8.89 | 9.83 | 1.0 | 13.6 | 44.1 | 50 | 6AR | |
| SMA6HS8.5A-Q1 | 8.5 | 9.44 | 10.4 | 1.0 | 14.4 | 41.7 | 20 | 6AT | |
| SMA6HS9.0A-Q1 | 9.0 | 10.0 | 11.1 | 1.0 | 15.4 | 39.0 | 10 | 6AV | |
| SMA6HS10A-Q1 | 10 | 11.1 | 12.3 | 1.0 | 17.0 | 35.3 | 5 | 6AX | |
| SMA6HS11A-Q1 | 11 | 12.2 | 13.5 | 1.0 | 18.2 | 33.0 | 5 | 6AZ | |
| SMA6HS12A-Q1 | 12 | 13.3 | 14.7 | 1.0 | 19.9 | 30.2 | 5 | 6BE | |
| SMA6HS13A-Q1 | 13 | 14.4 | 15.9 | 1.0 | 21.5 | 27.9 | 5 | 6BG | |
| SMA6HS14A-Q1 | 14 | 15.6 | 17.2 | 1.0 | 23.2 | 25.9 | 5 | 6BK | |
| SMA6HS15A-Q1 | 15 | 16.7 | 18.5 | 1.0 | 24.4 | 24.6 | 5 | 6BM | |
| SMA6HS16A-Q1 | 16 | 17.8 | 19.7 | 1.0 | 26.0 | 23.0 | 5 | 6BP | |
| SMA6HS17A-Q1 | 17 | 18.9 | 20.9 | 1.0 | 27.6 | 21.7 | 5 | 6BR | |
| SMA6HS18A-Q1 | 18 | 20.0 | 22.1 | 1.0 | 29.2 | 20.5 | 5 | 6BT | |
| SMA6HS20A-Q1 | 20 | 22.2 | 24.5 | 1.0 | 32.4 | 18.5 | 5 | 6BV | |
| SMA6HS22A-Q1 | 22 | 24.4 | 26.9 | 1.0 | 35.5 | 16.9 | 5 | 6BX | |
| SMA6HS24A-Q1 | 24 | 26.7 | 29.5 | 1.0 | 38.9 | 15.4 | 5 | 6BZ | |
| SMA6HS26A-Q1 | 26 | 28.9 | 31.9 | 1.0 | 42.1 | 14.2 | 5 | 6CE | |
| SMA6HS28A-Q1 | 28 | 31.1 | 34.4 | 1.0 | 45.4 | 13.2 | 5 | 6CG | |
| SMA6HS30A-Q1 | 30 | 33.3 | 36.8 | 1.0 | 48.4 | 12.4 | 5 | 6CK | |
| SMA6HS33A-Q1 | 33 | 36.7 | 40.6 | 1.0 | 53.3 | 11.2 | 5 | 6CM | |
| SMA6HS36A-Q1 | 36 | 40.0 | 44.2 | 1.0 | 58.1 | 10.3 | 5 | 6CP | |
| SMA6HS40A-Q1 | 40 | 44.4 | 49.1 | 1.0 | 64.5 | 9.3 | 5 | 6CR | |
| SMA6HS43A-Q1 | 43 | 47.8 | 52.8 | 1.0 | 69.4 | 8.6 | 5 | 6CT | |
| SMA6HS45A-Q1 | 45 | 50.0 | 55.3 | 1.0 | 72.7 | 8.2 | 5 | 6CV | |
| SMA6HS48A-Q1 | 48 | 53.3 | 58.9 | 1.0 | 77.4 | 7.7 | 5 | 6CX | |
| SMA6HS51A-Q1 | 51 | 56.7 | 62.7 | 1.0 | 82.4 | 7.2 | 5 | 6CZ | |
| SMA6HS54A-Q1 | 54 | 60.0 | 66.3 | 1.0 | 87.1 | 6.9 | 5 | 6RE | |
| SMA6HS58A-Q1 | 58 | 64.4 | 71.2 | 1.0 | 93.6 | 6.4 | 5 | 6RG | |
| SMA6HS60A-Q1 | 60 | 66.7 | 73.7 | 1.0 | 96.8 | 6.2 | 5 | 6RK | |
| SMA6HS64A-Q1 | 64 | 71.1 | 78.6 | 1.0 | 103.0 | 5.8 | 5 | 6RM | |
| SMA6HS70A-Q1 | 70 | 77.8 | 86.0 | 1.0 | 113.0 | 5.3 | 5 | 6RP | |
| SMA6HS75A-Q1 | 75 | 83.3 | 92.1 | 1.0 | 121.0 | 4.9 | 5 | 6RR | |
| SMA6HS78A-Q1 | 78 | 86.7 | 95.8 | 1.0 | 126.0 | 4.7 | 5 | 6RT | |
| SMA6HS85A-Q1 | 85 | 94.4 | 104 | 1.0 | 137.0 | 4.3 | 5 | 6RV | |

Notes 1. V_{BR} measured after I_T applied for 300 μs , I_T =square wave pulse or equivalent

2. Surge current waveform per Fig. 3 and derated per Fig. 2

3. Suffix 'A' denotes 5% tolerance devices

4. All terms and symbols are consistent with ANS/IEEE C62.35

5. Transient Voltage Suppressors (TVS) are devices used to protect vulnerable circuits from electrical overstress such as that caused by electrostatic discharge, inductive load switching and induced lightning. Within the TVS, damaging voltage spikes are limited by clamping or avalanche action of a rugged silicon pn junction which reduces the amplitude of the transient to a nondestructive level. See Fig. 7 & Fig. 8

Rating and characteristic curves (SMA6HS-Q1 SERIES)

Fig.1 - Peak Pulse Power Rating Curve

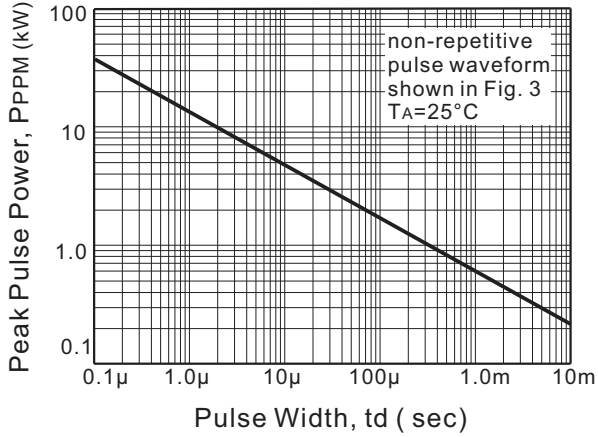

Fig.2 - Pulse Derating Curve

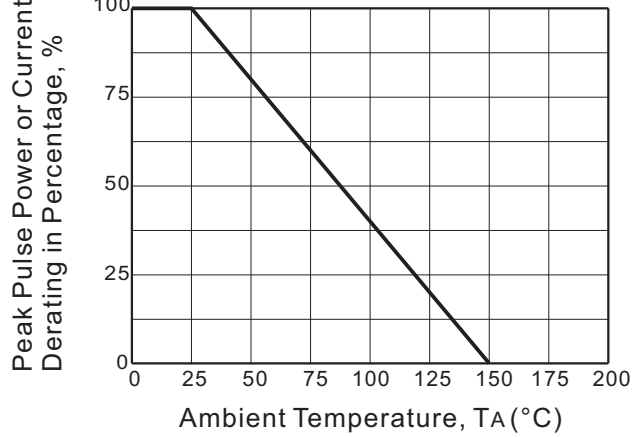

Fig.3 - Pulse Waveform

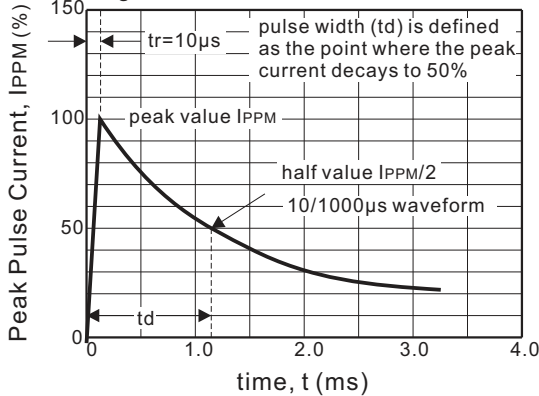

Fig.4 - Typical Junction Capacitance

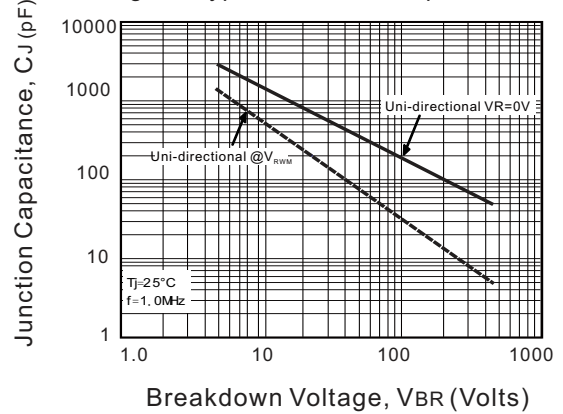

Fig.5 - Steady State Power Derating Curve

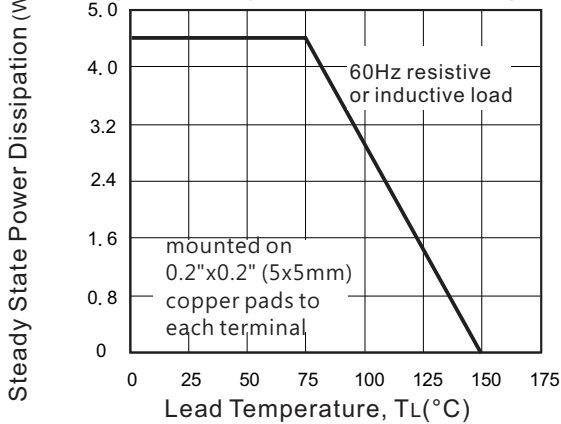
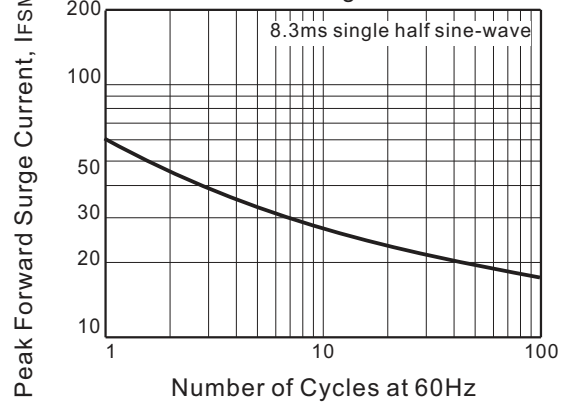

Fig.6 - Maximum Non-Repetitive Forward Surge Current



Rating and characteristic curves (SMA6HS-Q1 SERIES)

Fig. 7 - Transients of several thousand volts can be clamped to a safe level by the TVS

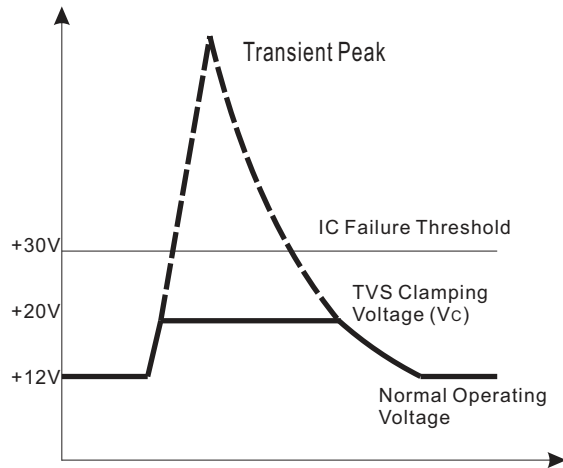
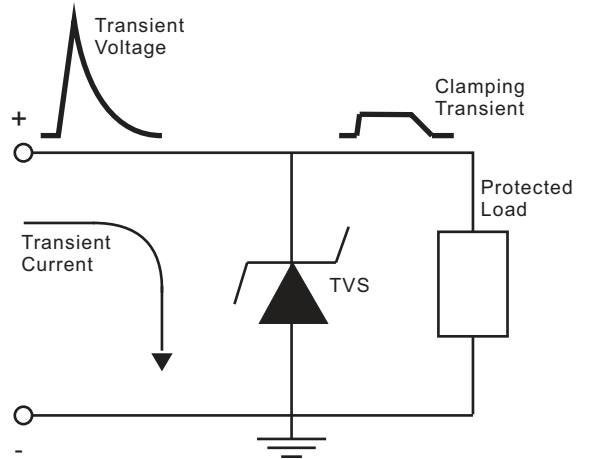

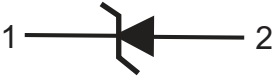

Fig. 8 - Transient current is diverted to ground thru TVS; the voltage seen by the protected load is limited to the clamping voltage level



SMA6HS5.0A-Q1 THRU SMA6HS85A-Q1

Pinning information

| Pin | Simplified outline | Symbol |
|---|--|---|
| Uni-Directional Pin1 cathode Pin2 anode |  |  |

Marking

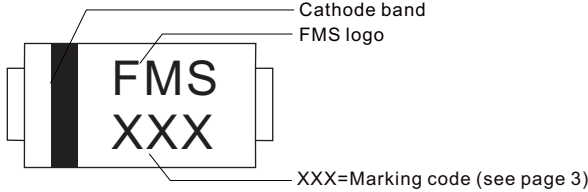
| Type number | Example |
|-----------------|---|
| Uni-Directional |  |

Suggested solder pad layout

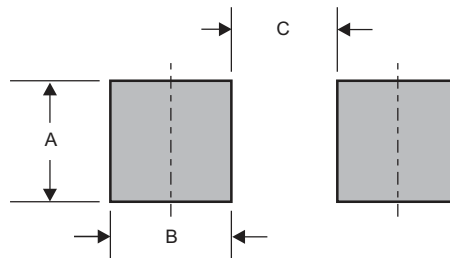

Dimensions in inches and (millimeters)

| PACKAGE | A | B | C |
|---------|--------------|--------------|--------------|
| SMA-HS | 0.060 (1.52) | 0.048 (1.20) | 0.123 (3.12) |

SMA6HS5.0A-Q1 THRU SMA6HS85A-Q1

Packing information

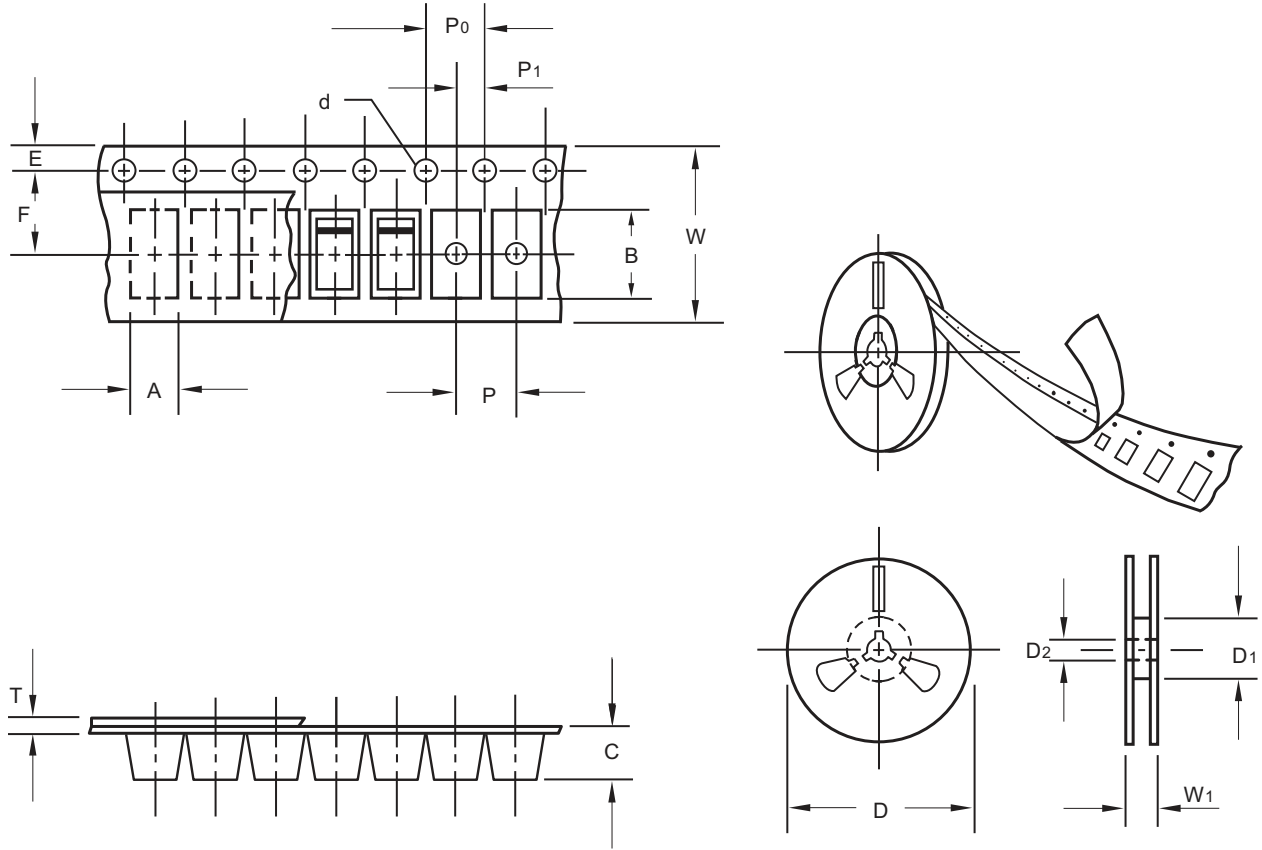

unit:mm

| Item | Symbol | Tolerance | SMA-HS |
|---------------------------|--------|-----------|--------|
| Carrier width | A | 0.1 | 3.00 |
| Carrier length | B | 0.1 | 5.50 |
| Carrier depth | C | 0.1 | 1.20 |
| Sprocket hole | d | 0.1 | 1.50 |
| 13" Reel outside diameter | D | 2.0 | 330.00 |
| 13" Reel inner diameter | D1 | min | 50.00 |
| 7" Reel outside diameter | D | 2.0 | 178.00 |
| 7" Reel inner diameter | D1 | min | 62.00 |
| Feed hole diameter | D2 | 0.5 | 13.00 |
| Sprocket hole position | E | 0.1 | 1.75 |
| Punch hole position | F | 0.1 | 5.50 |
| Punch hole pitch | P | 0.1 | 4.00 |
| Sprocket hole pitch | P0 | 0.1 | 4.00 |
| Embossment center | P1 | 0.1 | 2.00 |
| Overall tape thickness | T | 0.1 | 0.25 |
| Tape width | W | 0.3 | 12.00 |
| Reel width | W1 | 1.0 | 11.40 |

Note: Devices are packed in accordance with EIA standard RS-481-A and specifications listed above.

SMA6HS5.0A-Q1 THRU SMA6HS85A-Q1

Reel packing

| PACKAGE | REEL SIZE | REEL (pcs) | COMPONENT SPACING (m/m) | BOX (pcs) | INNER BOX (m/m) | REEL DIA, (m/m) | CARTON SIZE (m/m) | CARTON (pcs) | APPROX. GROSS WEIGHT (kg) |
|---------|-----------|------------|-------------------------|-----------|-----------------|-----------------|-------------------|--------------|---------------------------|
| SMA-HS | 7" | 3,000 | 4.0 | 30,000 | 183*155*183 | 178 | 382*356*392 | 240,000 | 18.0 |
| | 13" | 10,000 | 4.0 | 20,000 | 335*335*38 | 330 | 350*330*360 | 160,000 | 15.5 |

Suggested thermal profiles for soldering processes

- 1.Storage environment: Temperature=5°C~40°C Humidity=55%±25%
- 2.Reflow soldering of surface-mount devices

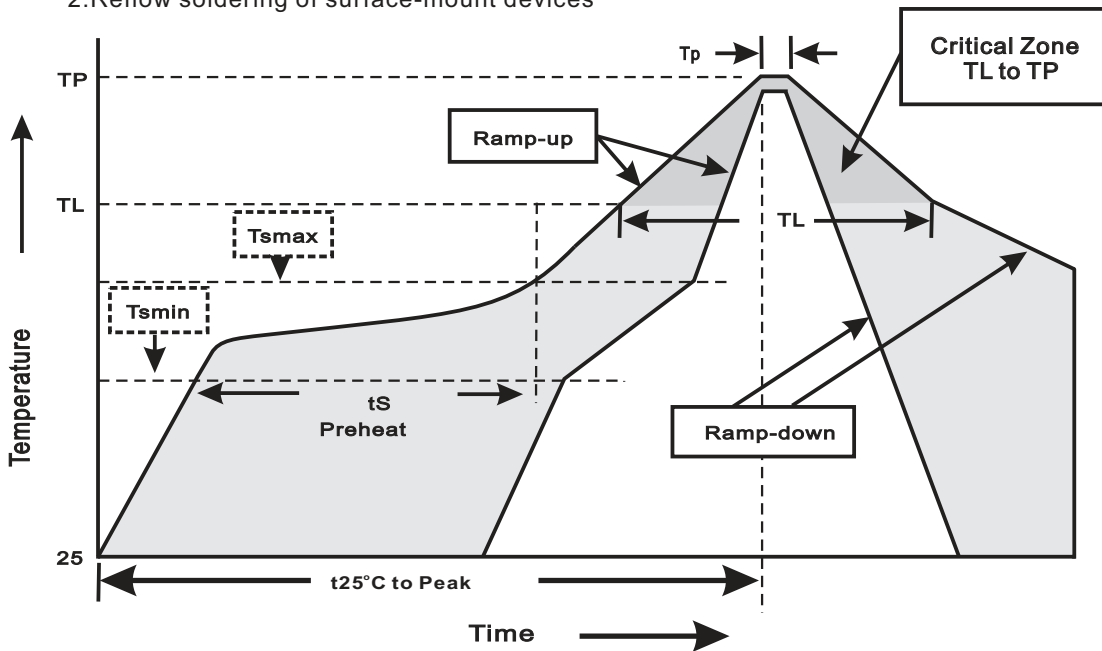

3.Reflow soldering

| Profile Feature | Soldering Condition |
|---|-----------------------------|
| Average ramp-up rate(T _L to T _P) | <3°C/sec |
| Preheat -Temperature Min(T _{smín}) -Temperature Max(T _{smáx}) -Time(min to max)(t _s) | 150°C 200°C 60~120sec |
| T _{smáx} to T _L -Ramp-upRate | <3°C/sec |
| Time maintained above: -Temperature(T _L) -Time(t _L) | 217°C 60~260sec |
| Peak Temperature(T _P) | 255°C-0/+5°C |
| Time within 5°C of actual Peak Temperature(t _P) | 10~30sec |
| Ramp-down Rate | <6°C/sec |
| Time 25°C to Peak Temperature | <6minutes |

SMA6HS5.0A-Q1 THRU SMA6HS85A-Q1**High reliability test capabilities**

| Item Test | Conditions | Reference |
|--|--|-------------------------------|
| 1. MSL Preconditioning | 24hr bake@125°C+168hrs@85°C /85%RH+3xIR@260°C+1flux immersion+alcohol+DI H2O rinse | JESD22-A113 |
| 2. High Temperature Reverse Bias | $V_{BR}=V_{BR\ NOM} * 80\%$ ($T_j=150^\circ\text{C}$) Test Duration:1000hrs | JESD22-A108 |
| 3. High Temperature Storage Life | $T_a=125^\circ\text{C}$ Test Duration:1000hrs | JESD22 A-103 |
| 4. Temperature Cycle | -55°C (15min) to 150°C (15min) Test Cycles:1000cycles | JESD22 A-104 |
| 5. Autoclave | $P=2\text{atm}$ $T_a=121^\circ\text{C}$ $\text{RH}=100\%$ Test Duration:96hrs | JESD22 A-102 |
| 6. Solderability | $245\pm 5^\circ\text{C}$ for 5sec | J-STD-002 |
| 7. Moisture Resistance | $T_a=85^\circ\text{C}/85\%$ Relative humidity Test Duration:1000hrs | MIL-STD-750E METHOD 1021.2 |
| 8. Resistance To Solder Heat | $260\pm 5^\circ\text{C}$ for 10sec | JESD22 B-106 |
| 9. High Temperature High Humidity Reverse Bias | $T_a=85^\circ\text{C}$, 85%RH, with device reverse biased at 80% of rated breakdown voltage up to a maximum of 100V or limit of chamber Test Duration:1000hrs | JESD22-A101 |