

**SMA FEMALE - SMP-MAX SLIDE MALE**

**R191.552.000**

**STRAIGHT ADAPTER**

Série : ADAPTER

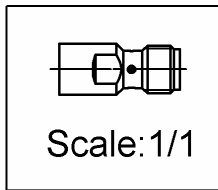
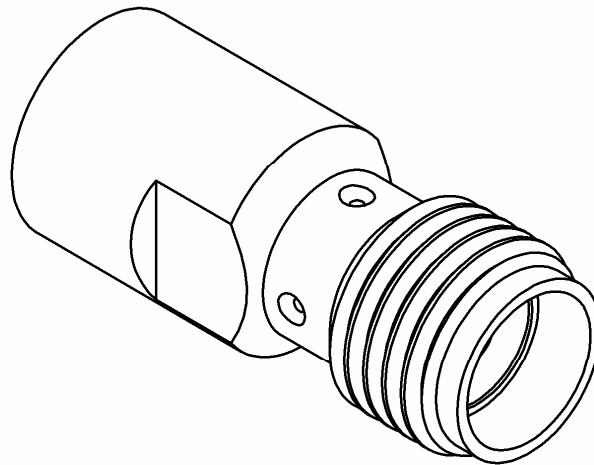
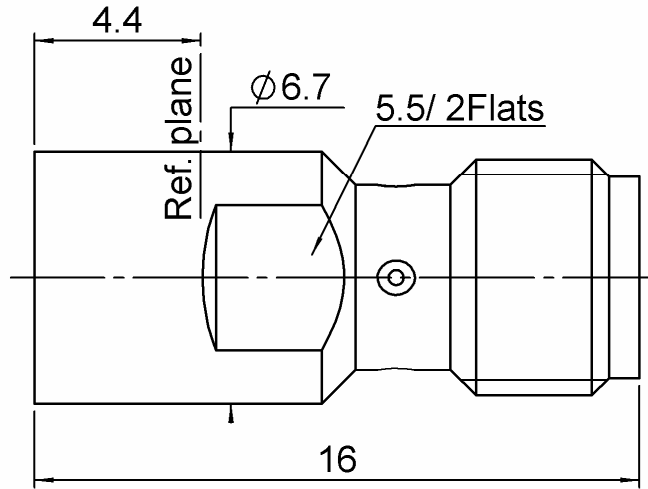

All dimensions are in mm.

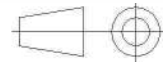

COMPONENTS	MATERIALS	PLATING (µm)
BODY	BRASS	NPGR
CENTER CONTACT	BERYLLIUM COPPER	NPGR
OUTER CONTACT		
INSULATOR	PTFE	
GASKET		
OTHERS PARTS		
-	-	-
-	-	-

Issue : 1203 A

In the effort to improve our products, we reserve the rights to make changes judged to be necessary.



**SMA FEMALE - SMP-MAX SLIDE MALE**

**R191.552.000**

**STRAIGHT ADAPTER**

Série : ADAPTER

**PACKAGING**

**SPECIFICATION**

Standard	Unit	Other
<b>1</b>	-	<b>Contact us</b>

**ELECTRICAL CHARACTERISTICS**

**ENVIRONMENTAL**

Impedance	<b>50</b>	$\Omega$
Frequency	<b>0-6</b>	GHz
VSWR	<b>1.03 + 0,0300</b>	x F(GHz) Maxi
Insertion loss	<b>0.05</b>	$\sqrt{F}$ (GHz) dB Maxi
RF leakage	- ( <b>NA</b> )	- F(GHz)) dB Maxi
Voltage rating	<b>335</b>	Veff Maxi
Dielectric withstanding voltage	<b>1000</b>	Veff mini
Insulation resistance	<b>5000</b>	M $\Omega$ mini

Operating	<b>-55/+125</b>	$^{\circ}$ C
Hermetic seal	<b>NA</b>	Atm.cm3/s
Panel leakage	<b>NA</b>	

**MECHANICAL CHARACTERISTICS**

**OTHER CHARACTERISTICS**

Center contact retention		
Axial force – Mating end	<b>7</b>	N mini
Axial force – Opposite end	<b>18</b>	N mini
Torque	<b>NA</b>	N.cm mini
Recommended torque		
Mating	<b>SMP-MAX</b>	<b>0</b> N.cm
	<b>SMA-COM</b>	<b>0</b> N.cm
		<b>0</b> N.cm
Panel nut	<b>NA</b>	N.cm
Mating life	<b>100</b>	Cycles mini
Weight	<b>2,5610</b>	g

Issue : 1203 A

In the effort to improve our products, we reserve the rights to make changes judged to be necessary.

