

F6921

Dual-Channel Low Noise Amplifier 10.7 – 12.75 GHz

The F6921 is an ultra-low power consumption, dual-channel, low noise amplifier (LNA) RFIC designed for application in Ku-Band SATCOM planar phased array antennas. The exceptional combination of low power consumption, low noise, high gain, and compact size, maximizes the antenna array G/T while minimizing overall system power dissipation. An external bias current provides gain control, standby mode and temperature compensation.

The F6921 includes two independent gain/phase matched LNA channels in a compact 23-pin, 0.5mm pitch BGA package. All inputs and outputs are single-ended and 50Ω matched for ease of integration on to phased array antenna panels.

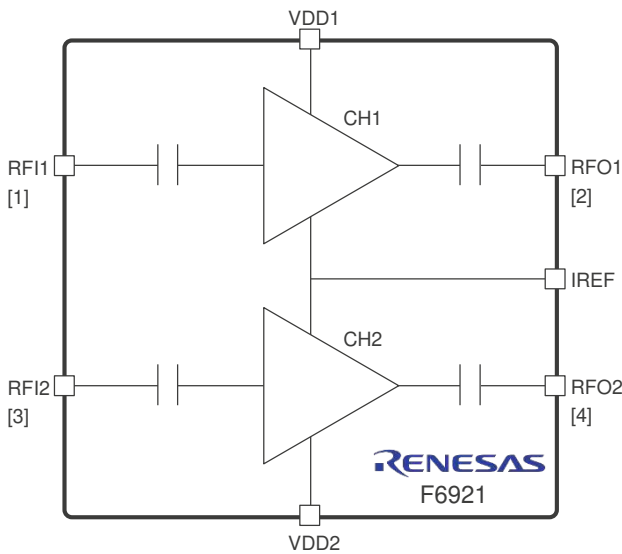

Figure 1. Block Diagram

Features

- Frequency: 10.7 – 12.75 GHz
- Gain: 19.5dB
- Noise Figure: 1.4dB
- Output P1dB: -7dBm
- Power Consumption: 12.5mW/ch
- Channel Isolation: 37dB minimum
- Supply Voltage: 0.9 – 1.0V
- Common bias control input
- Compact size for planar integration on λ/2 grid
- 2.7 × 2.7 × 0.9 mm, 23-pin BGA
- -40°C to +85°C ambient operating temperature range

Note: Performance is typical at 11.7GHz. See the Specifications and Typical Performance Characteristics sections for more details.

Applications

- Electronically Steered Phased Array Antennas (ESAs)
- Aerospace, Maritime, and Satcom-on-the-move (SOTM)
- Ku-Band SATCOM Terminals
- Communication, Electronic Warfare (EW) and Radar Systems

Contents

1. Pin Information	4
1.1 Pin Assignments	4
1.2 Pin Descriptions	4
2. Specifications	5
2.1 Absolute Maximum Ratings	5
2.2 Thermal Information	5
2.3 Recommended Operating Conditions	6
2.4 Electrical Specifications	6
2.4.1 DC Electrical Specifications	6
2.4.2 RF Electrical Specifications	7
3. Typical Application Circuit	8
4. Typical Performance Characteristics	9
5. Evaluation Board	11
5.1 Evaluation Board Photos	11
5.2 Evaluation Board Schematic	12
5.3 Evaluation Board Operation	13
5.3.1 Single Power Supply Operation	13
5.3.2 Independent VDD and IREF Bias Control	13
6. Package Outline Drawings	14
7. Marking Diagram	14
8. Ordering Information	14
9. Revision History	14

Figures

Figure 1. Block Diagram	1
Figure 2. Pin Assignments for 2.7 × 2.7 mm 23-pin FCBGA Package – Top View	4
Figure 3. Typical Application Circuits	8
Figure 4. Gain	9
Figure 5. Noise Figure	9
Figure 6. Input Match	9
Figure 7. Output Match	9
Figure 8. Input-to-Output Isolation	9
Figure 9. Ch-to-Ch Isolation	9
Figure 10. Output 1dB Compression	10
Figure 11. Output Third Order Intercept	10
Figure 12. Supply Current, Per Channel	10
Figure 13. IREF Pin Voltage vs Current	10
Figure 14. Evaluation Board - Top View	11
Figure 15. Evaluation Board - Bottom View	11
Figure 16. Evaluation Board - Schematic	12

Tables

Table 1. Bill of Material (BOM) 12

1. Pin Information

1.1 Pin Assignments

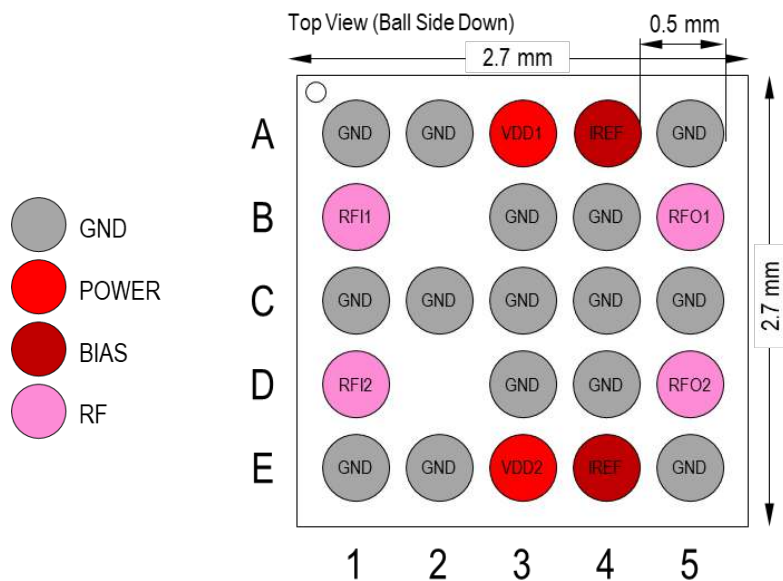

Figure 2. Pin Assignments for 2.7 × 2.7 mm 23-pin FCBGA Package – Top View

1.2 Pin Descriptions

Pin Number	Name	Type	I/O	Description
A1, A2, A5, B3, B4, C1, C2, C3, C4, C5, D3, D4, E1, E2, E5	GND	Ground	–	DC and RF ground.
A3	VDD1	Power	Input	Positive supply voltage input for channel 1.
E3	VDD2	Power	Input	Positive supply voltage input for channel 2.
A4, E4	IREF	Power	Input	Reference bias current input, tied to a common node shared by channels 1 and 2. Connect directly to a current source, voltage source through a resistor, or to the IBx pin of the F61xx.
B1	RFI1	Analog	Input	Channel 1 RF input port.
D1	RFI2	Analog	Input	Channel 2 RF input port.
B5	RFO1	Analog	Output	Channel 1 RF output port.
D5	RFO2	Analog	Output	Channel 2 RF output port.

2. Specifications

Exposure of the device to parameter values outside of the range listed below may reduce the operating lifetime and adversely and permanently alter the device characteristics. Furthermore, functional operation at or near absolute maximum ratings is not implied.

2.1 Absolute Maximum Ratings

Parameter	Symbol	Conditions	Minimum	Maximum	Units
Supply Voltage	V _{DD}		-0.3	1.2	V
Reference Current	I _{REF}		0	250	μA
Input RF Pin DC Voltage	V _{DC_RFI}		-0.3	1.0	V
Output RF Pin DC Voltage	V _{DC_RFO}		-0.3	1.2	V
RF Input Power	P _{IN}	V _{DD} = 1.0V, VSWR<2:1		0	dBm
Junction Temperature	T _J			125	°C
ESD – Human Body Model	V _{HBM}	JS-001-2012		750	V
ESD – Charged Device Model	V _{CDM}	JESD22-C101		250	V

2.2 Thermal Information

Parameter	Symbol	Value	Units
Theta JB. Junction to board.	θ _{JB}	14	°C/W
Theta JC. Junction to case. (case top)	θ _{JC}	108	°C/W
Theta JA. Junction to ambient.	θ _{JA}	47	°C/W
Storage Temperature	T _{STOR}	-40 to +150	°C
Lead Temperature (soldering, 30s)	T _{LEAD}	260	°C

2.3 Recommended Operating Conditions

Parameter	Symbol	Minimum	Typical	Maximum	Units
RF Frequency Range	f_{RF}	10.7		12.75	GHz
Power Supply Voltage	V_{DD}	0.9	0.95	1.0	V
Reference Bias Current at -40°C	I_{REF}	43	50	58	μA
Reference Bias Current at +25°C		102	120	138	μA
Reference Bias Current at +85°C		156	184	212	μA
Ambient Temperature	T_A	-40		85	°C
RF Pin Load Impedance	Z_{RF}		50		Ω

2.4 Electrical Specifications

Specifications apply when operated at $T_{AMB} = 25^\circ C$.

2.4.1 DC Electrical Specifications

Parameter	Symbol	Conditions	Minimum	Typical	Maximum	Units
Supply Current, Per Channel	I_{DD}	$V_{DD} = 0.95V, I_{REF} = 120\mu A$		13		mA
Supply Current, Idle-state ^[1]	I_{DD_IDLE}	$I_{REF} = 0\mu A$		1		μA

1. IREF pin may be grounded or floating to achieve idle-state.

2.4.2. RF Electrical Specifications

Unless stated otherwise, all specifications are for $V_{DD} = 0.95V$, $I_{REF} = 120\mu A$, $T_{AMB} = 25^{\circ}C$, $Z_S = Z_L = 50\Omega$, $f_{RF} = 11.7GHz$.

Parameter	Symbol	Condition	Minimum	Typical	Maximum	Units
Gain	G			19.5		dB
Gain Flatness vs. Frequency	G_{VAR_FREQ}	$f_{RF} = 10.7 - 12.75 GHz$		0.9		dB
		Within any 250MHz		0.16		dB
Noise Figure	NF			1.4		dB
Output 1dB Compression Point	OP1dB			-7		dBm
Output 3 rd Order Intercept Point	OIP3	Pin = -35 dBm/tone, $\Delta f = 1MHz$		2		dBm
Input Return Loss	IRL			22		dB
Output Return Loss	ORL			12		dB
Reverse Isolation	ISO			35		dB
Channel-to-channel Isolation	ISO_{CH-CH}	$f_{RF} = 10.7 - 12.75 GHz$	37			dB

3. Typical Application Circuit

Figure 3 shows two typical application circuits for biasing the F6921.

The top circuit uses a voltage source V_{ref} to supply the bias reference current I_{ref} through an external resistor R_{ref} . V_{ref} should be set to achieve the recommended I_{ref} bias currents per the indicated formula. Refer to Figure 13 for the typical relationship between V_{iref} and I_{ref} .

The bottom circuit uses the programmable IDAC of the Renesas F61XX beamforming IC to provide the reference current directly to the F6921.

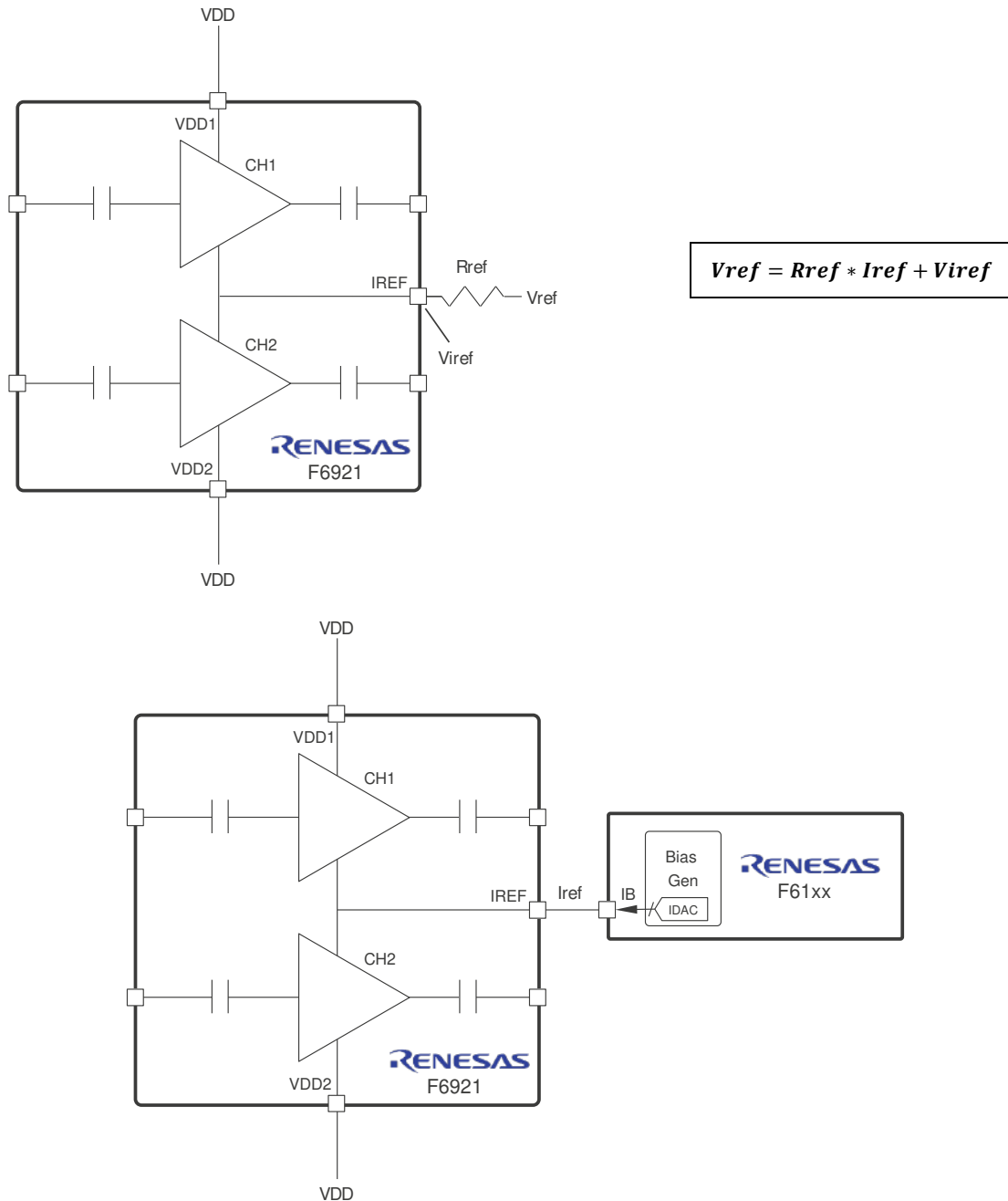

Figure 3. Typical Application Circuits

4. Typical Performance Characteristics

Unless stated otherwise, $Z_S = Z_L = 50\Omega$ on all RF ports, $V_{DD} = 0.95V$, $T_{AMB} = 25^\circ C$, Typical Recommended I_{REF}

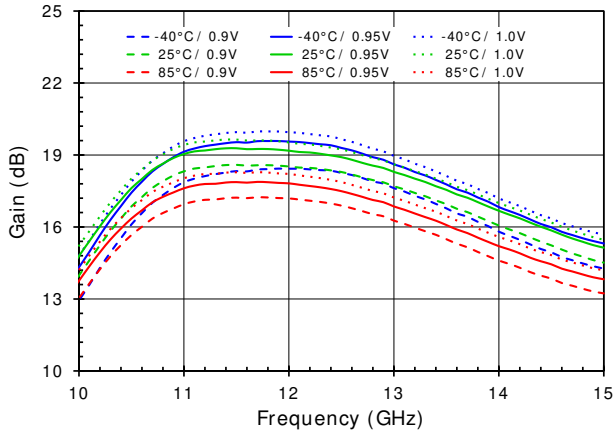

Figure 4. Gain

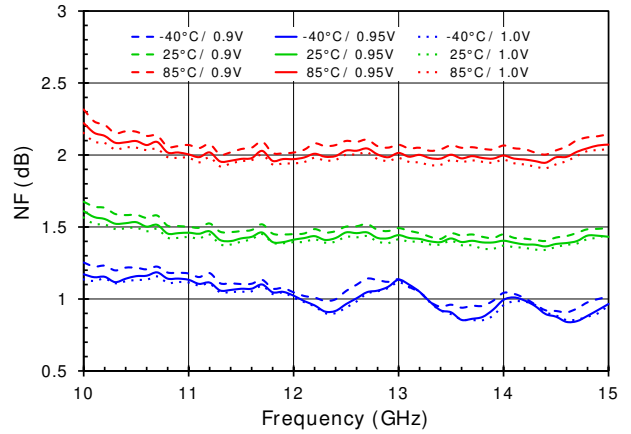

Figure 5. Noise Figure

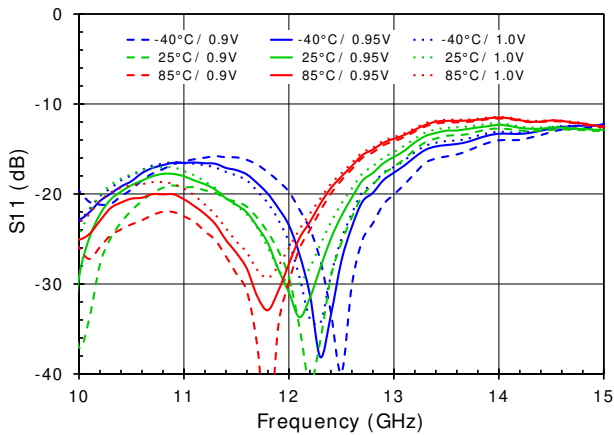

Figure 6. Input Match

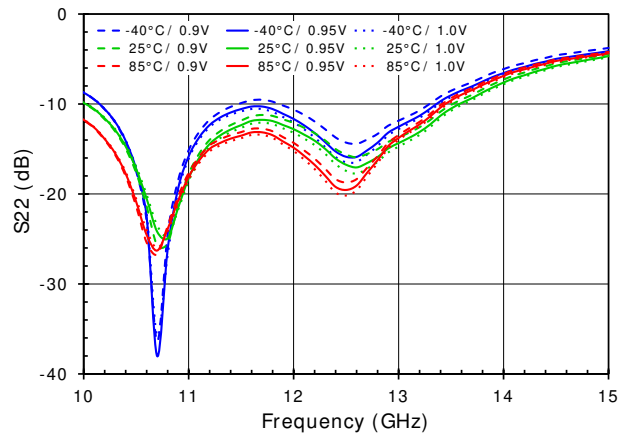

Figure 7. Output Match

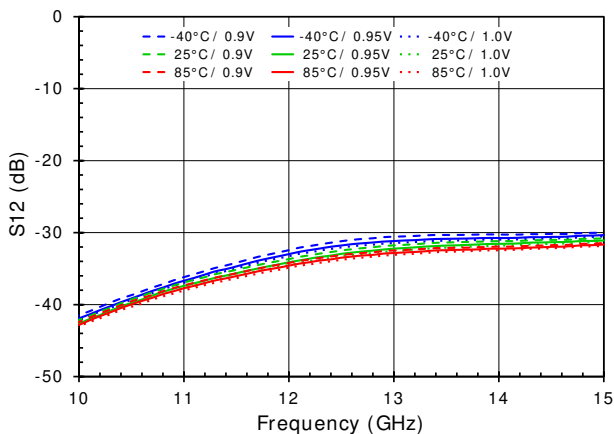

Figure 8. Input-to-Output Isolation

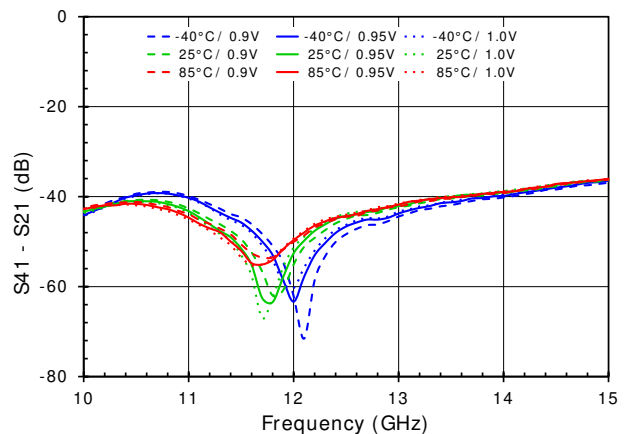

Figure 9. Ch-to-Ch Isolation

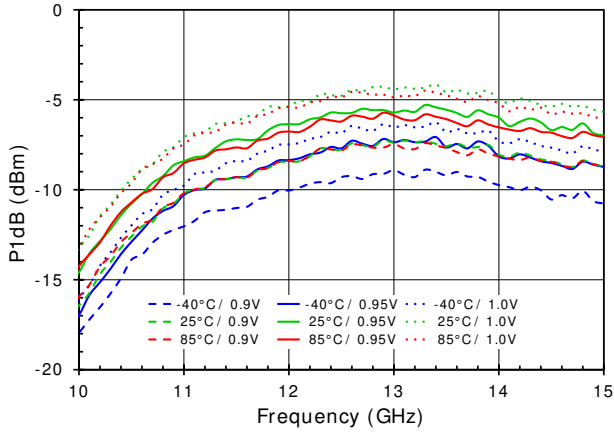

Figure 10. Output 1dB Compression

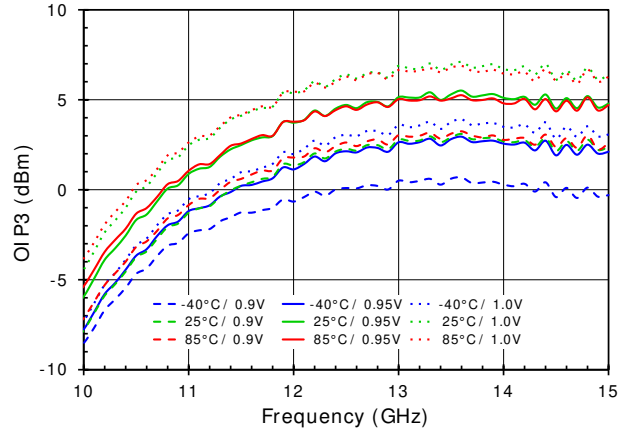

Figure 11. Output Third Order Intercept

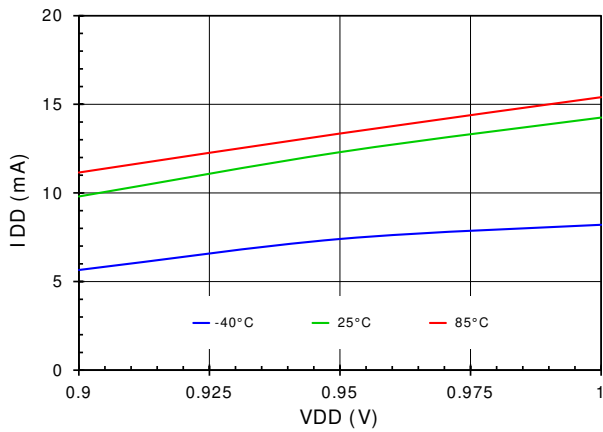

Figure 12. Supply Current, Per Channel

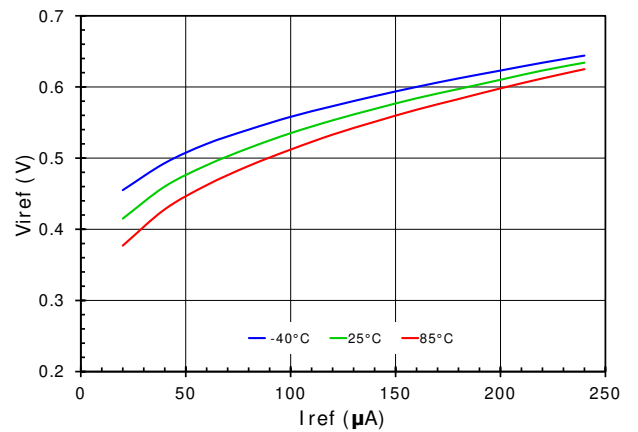

Figure 13. IREF Pin Voltage vs Current

5. Evaluation Board

For more information about the evaluation board, see the *F69xx Evaluation Board Manual* on the [F6921](#) product page.

5.1 Evaluation Board Photos

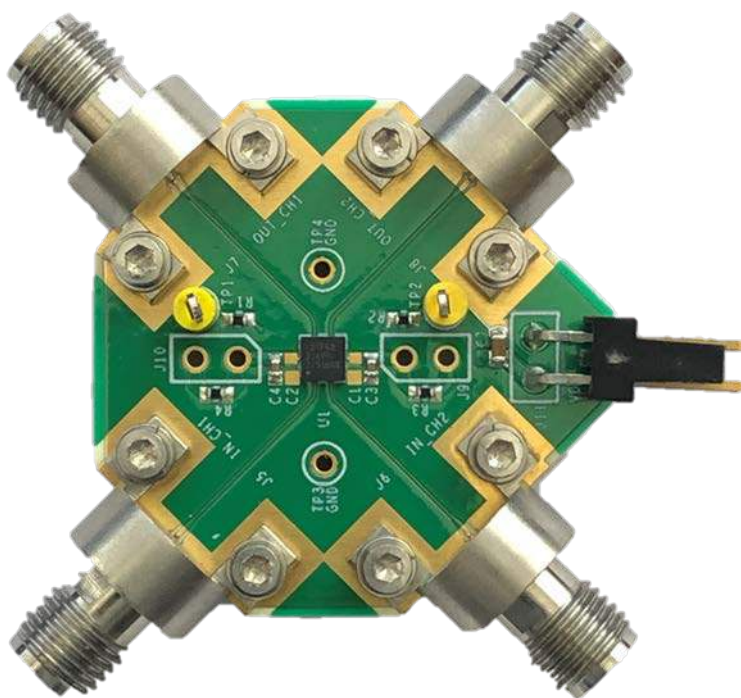

Figure 14. Evaluation Board - Top View

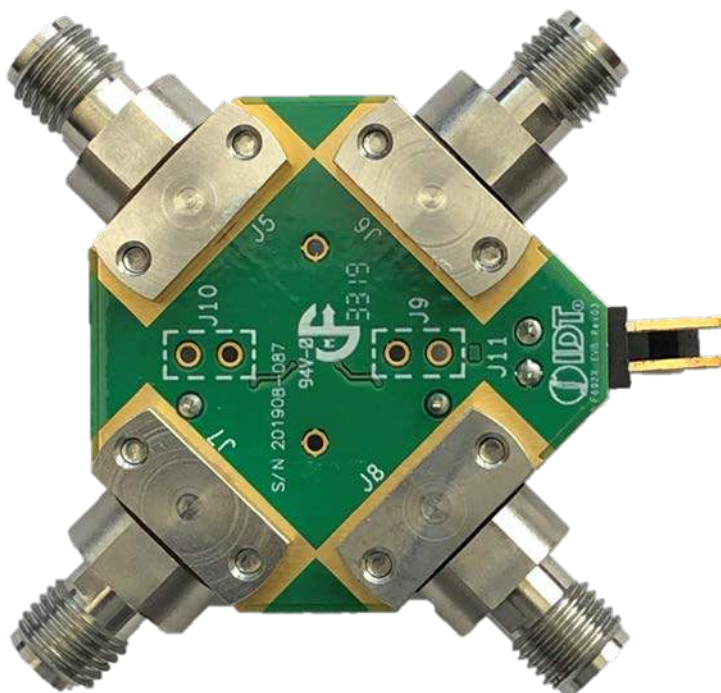

Figure 15. Evaluation Board - Bottom View

5.2 Evaluation Board Schematic

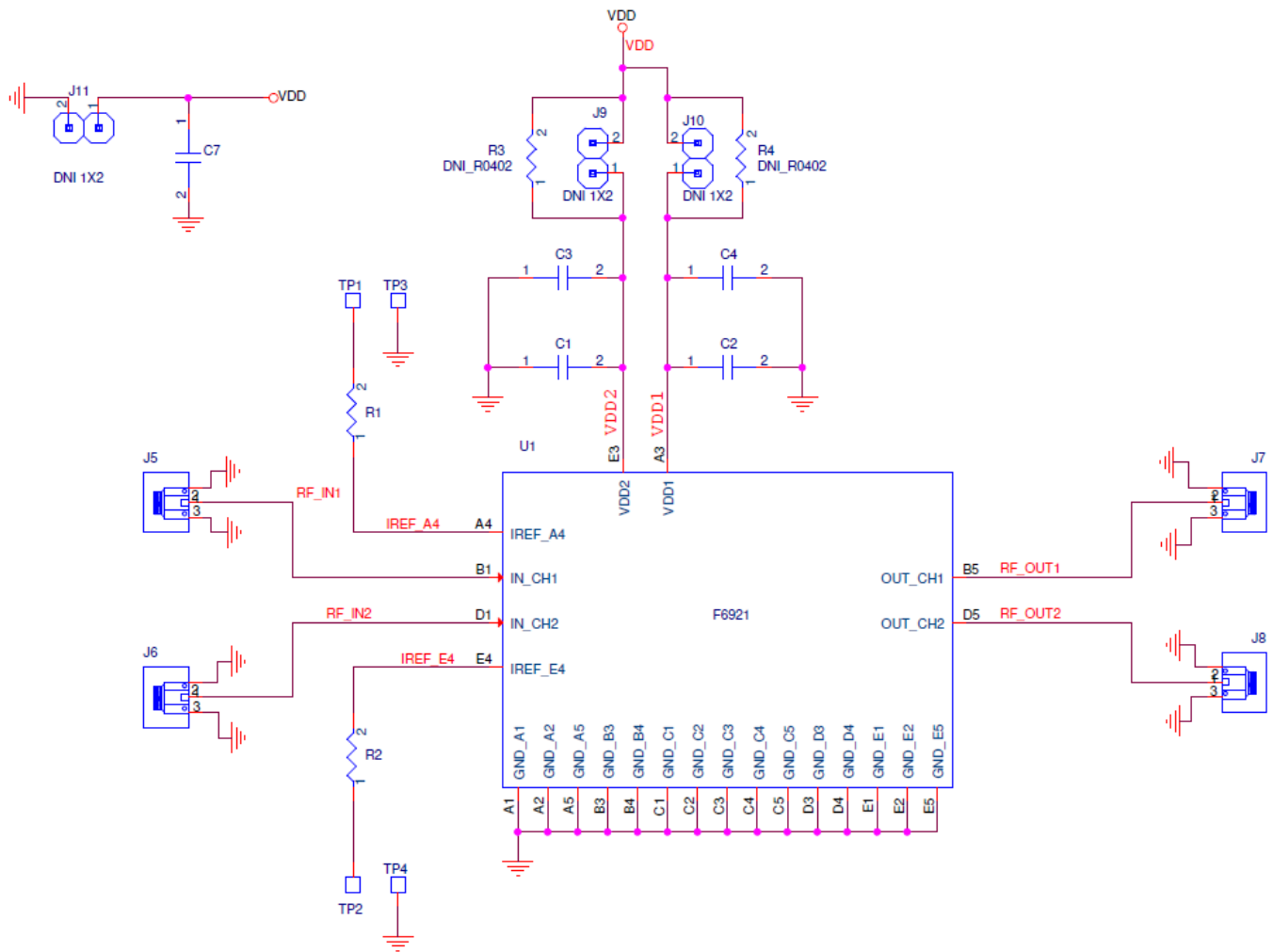

Figure 16. Evaluation Board - Schematic

Table 1. Bill of Material (BOM)

Part Reference	QTY	Description	Manufacturer Part #	Manufacturer
C1, C2	2	33pF ±5%, 50V, C0G Ceramic Capacitor (0402)	GRM1555C1H330J	MURATA
C3, C4	2	1uF ±10%, 16V, X6S Ceramic Capacitor (0402)	GRM155C81C105K	MURATA
C7	1	10uF ±20%, 16V, X6S Ceramic Capacitor (0603)	GRM188C81C106M	MURATA
R1	1	3.2kΩ ±1%, 1/16W, Resistor (0402)		
R2	1	DNI		
R3, R4	2	0Ω Resistors (0402)	ERJ-2GE0R00X	PANASONIC
J5-J8	4	Edge Launch 2.92mm 40GHz	ELF-40-002	SIGNAL MICROWAVE
TP1, TP2	2	Test Point Yellow	5004	Keystone Electronics
J11	1	CONN HEADER R/A 2POS 2.54MM	1718571002	MOLEX

5.3 Evaluation Board Operation

This section provides basic information on operating the F6921 evaluation board. For more information about the evaluation board, see the *F69xx Evaluation Board Manual* on the [F6921](#) product page.

5.3.1. Single Power Supply Operation

Connect the positive and negative outputs of a power supply (V_{DD}) to J11. In addition, connect the positive output of the V_{DD} supply to TP1. While there are two I_{REF} pins on the F6921 device (which are individually accessible via TP1 and TP2 on the evaluation board), these pins (A4 and E4) are internally connected to the same node on the IC, simultaneously controlling the bias of channels 1 and 2. Set the power supply to 0.95V and enable the power supply output. Monitor the V_{DD} supply output current to confirm the nominal bias point is set correctly (approximately 24mA).

5.3.2. Independent VDD and IREF Bias Control

5.3.2.1. Two Voltage Sources

Connect the positive and negative outputs of a power supply (V_{DD}) to J11. In addition, connect the positive output of a second supply (V_{REF}) to TP1 and the negative output to the negative output of the V_{DD} supply. Set both power supplies to 0.95V and enable the power supply outputs. Monitor the I_{DD} of the V_{DD} supply to confirm the nominal bias point is set correctly (approximately 24mA).

5.3.2.2. Voltage Source and Current Source

Connect the positive and negative outputs of a power supply (V_{DD}) to J11. In addition, connect an independent current supply (I_{REF}) to TP1 and the ground of the current supply to the negative terminal of the V_{DD} supply. Set V_{DD} to 0.95V, I_{REF} to 120 μ A and enable the power supply outputs. Monitor the I_{DD} of the V_{DD} supply to confirm the nominal bias point is set correctly (approximately 24mA).

6. Package Outline Drawings

The package outline drawings are located at the end of this document and are accessible from the Renesas website (see Ordering Information for POD links). The package information is the most current data available and is subject to change without revision of this document.

7. Marking Diagram

Top view (ball side down)

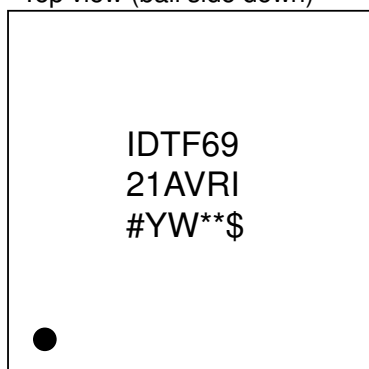

- Lines 1 and 2: Renesas part number
- Line 3:
 - # is the device step
 - YW is the last digit of the year and workweek code
 - **\$ is the lot sequential code and mark location code

8. Ordering Information

Orderable Part Number	Package	MSL Rating	Carrier Type	Temperature
F6921AVRI	2.7 × 2.7 × 0.9 mm 23-BGA	3	Tray	-40°C to +85°C
F6921AVRI8	2.7 × 2.7 × 0.9 mm 23-BGA	3	Reel	-40°C to +85°C
F6921EVB	F6921 Evaluation Board			

9. Revision History

Revision	Date	Description
1.0	Apr 8, 2021	Initial release. Final Datasheet.

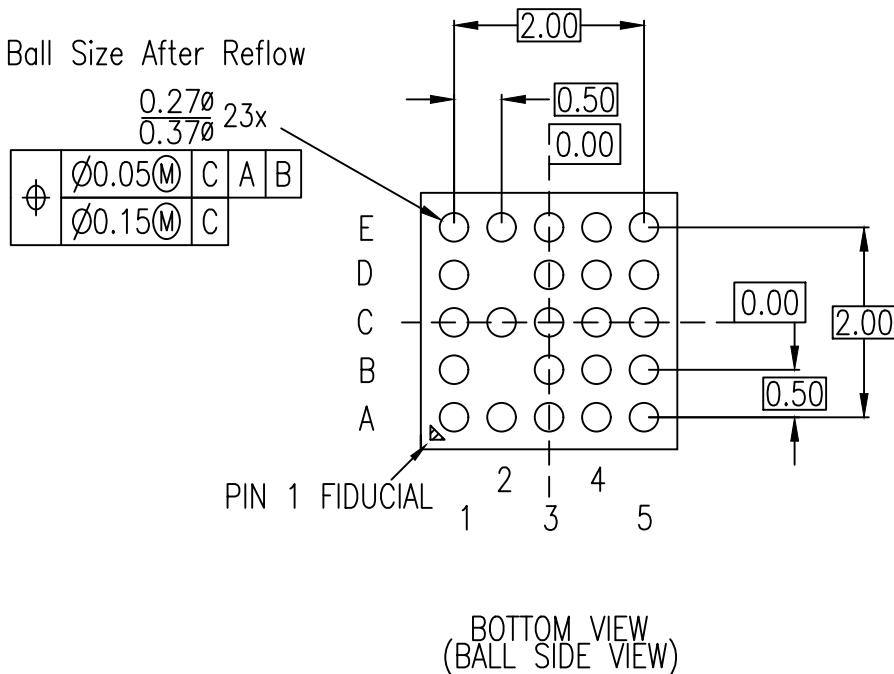
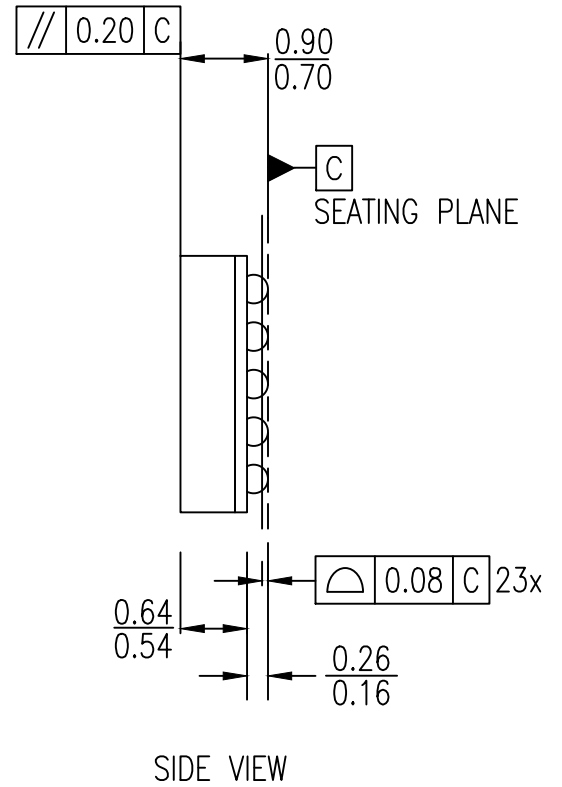
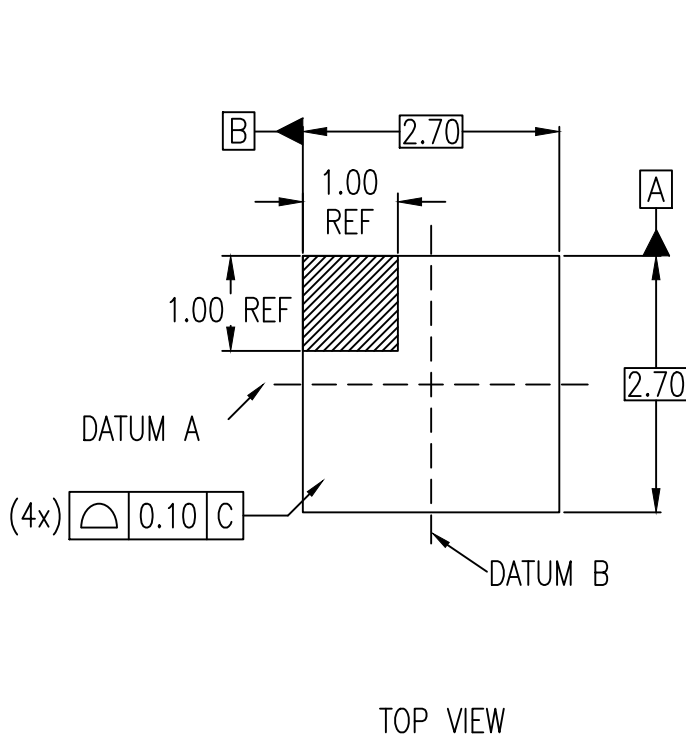

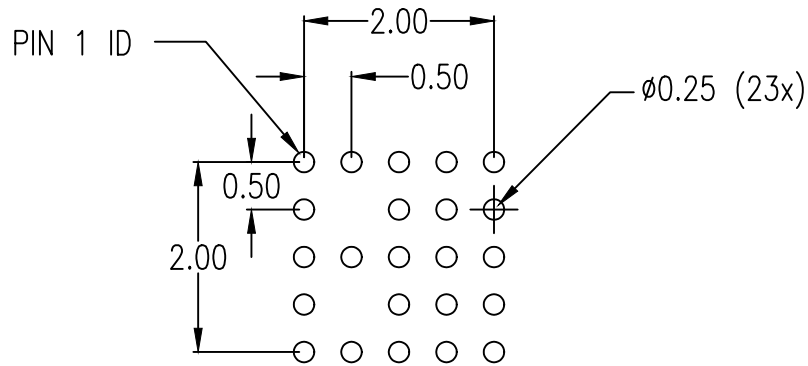

RECOMMENDED LAND PATTERN DIMENSION
(TOP VIEW)

NOTES:

1. ALL DIMENSION ARE IN MM. ANGLES IN DEGREES.
2. TOP DOWN VIEW. AS VIEWED ON PCB.
3. LAND PATTERN RECOMMENDATION PER IPC-7351B GENERIC REQUIREMENT FOR SURFACE MOUNT DESIGN AND LAND PATTERN.

Package Revision History		
Date Created	Rev No.	Description
Dec. 6, 2018	Rev 00	Initial Release

IMPORTANT NOTICE AND DISCLAIMER

RENESAS ELECTRONICS CORPORATION AND ITS SUBSIDIARIES (“RENESAS”) PROVIDES TECHNICAL SPECIFICATIONS AND RELIABILITY DATA (INCLUDING DATASHEETS), DESIGN RESOURCES (INCLUDING REFERENCE DESIGNS), APPLICATION OR OTHER DESIGN ADVICE, WEB TOOLS, SAFETY INFORMATION, AND OTHER RESOURCES “AS IS” AND WITH ALL FAULTS, AND DISCLAIMS ALL WARRANTIES, EXPRESS OR IMPLIED, INCLUDING, WITHOUT LIMITATION, ANY IMPLIED WARRANTIES OF MERCHANTABILITY, FITNESS FOR A PARTICULAR PURPOSE, OR NON-INFRINGEMENT OF THIRD PARTY INTELLECTUAL PROPERTY RIGHTS.

These resources are intended for developers skilled in the art designing with Renesas products. You are solely responsible for (1) selecting the appropriate products for your application, (2) designing, validating, and testing your application, and (3) ensuring your application meets applicable standards, and any other safety, security, or other requirements. These resources are subject to change without notice. Renesas grants you permission to use these resources only for development of an application that uses Renesas products. Other reproduction or use of these resources is strictly prohibited. No license is granted to any other Renesas intellectual property or to any third party intellectual property. Renesas disclaims responsibility for, and you will fully indemnify Renesas and its representatives against, any claims, damages, costs, losses, or liabilities arising out of your use of these resources. Renesas' products are provided only subject to Renesas' Terms and Conditions of Sale or other applicable terms agreed to in writing. No use of any Renesas resources expands or otherwise alters any applicable warranties or warranty disclaimers for these products.

(Disclaimer Rev.1.0 Mar 2020)

Corporate Headquarters

TOYOSU FORESIA, 3-2-24 Toyosu,
Koto-ku, Tokyo 135-0061, Japan
www.renesas.com

Contact Information

For further information on a product, technology, the most up-to-date version of a document, or your nearest sales office, please visit:
www.renesas.com/contact/

Trademarks

Renesas and the Renesas logo are trademarks of Renesas Electronics Corporation. All trademarks and registered trademarks are the property of their respective owners.